

Operações do cortante OS-D/ OS-T Perimetral

Sistema OS

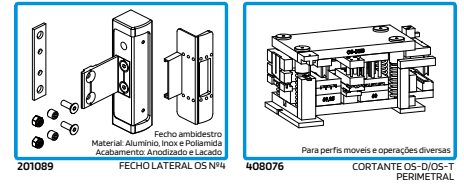

Maquinação dos perfis móveis SO 64, SO 65 e SO 66.  
 SO 64, SO 65 and SO 66 profiles machining.  
 Usinage des profilés mobiles SO 64, SO 65 et SO 66.

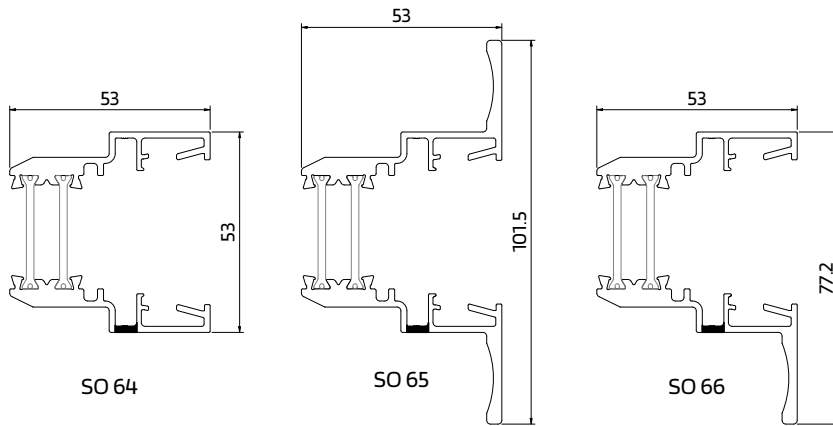

Maquinação realizada no Cortante  
 Machining performed on Punching tool  
 Usinage réalisée dans l'Outil

Marcar primeiro o centro do rasgo nos perfis para depois se maquinar na operação nº1.  
 First mark the centre of the slot on the profiles, then machine them in operation nº1  
 Marquer d'abord le centre de la fente sur les profilés, puis procéder à l'usinage lors de l'opération nº1.

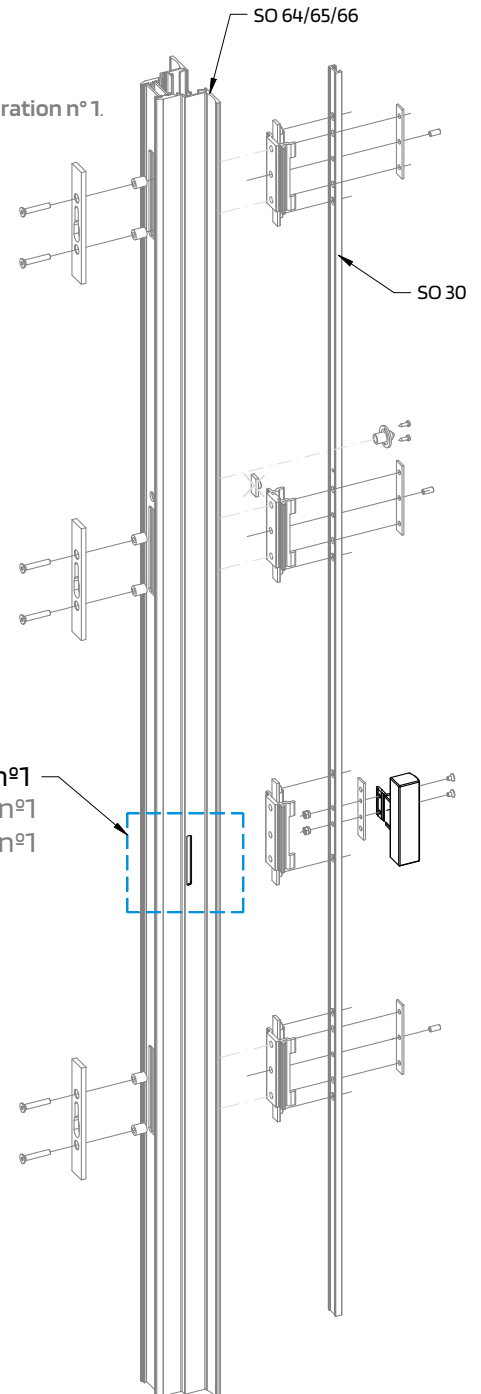
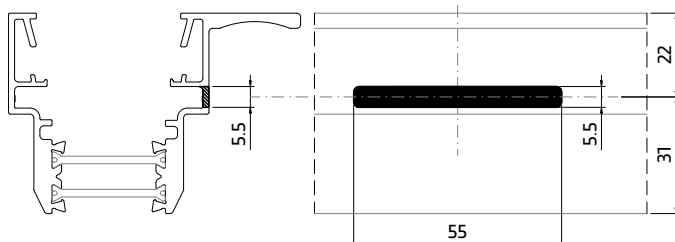
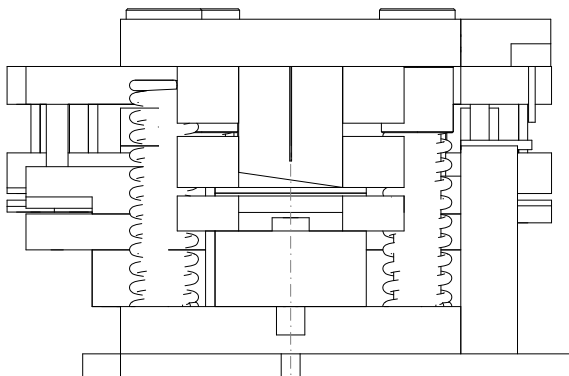
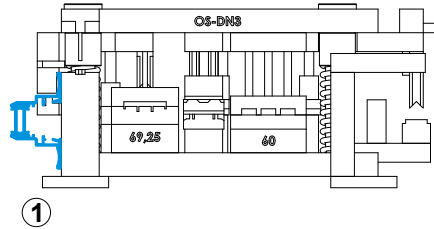
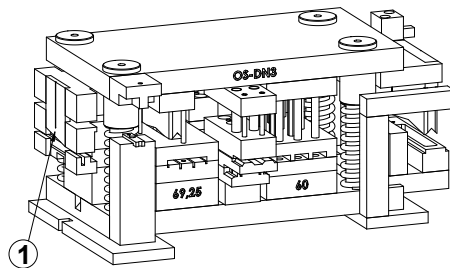

# Operações do cortante OS-D/ OS-T Perimetral

## Sistema OS



**Maquinação dos perfis móveis SO 08, SO 17 e SO 18.**  
 SO 08, SO 17 and SO 18 profiles machining.  
 Usinage des profilés mobiles SO 08, SO 17 et SO 18.

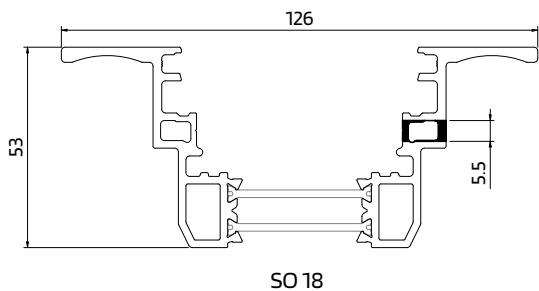
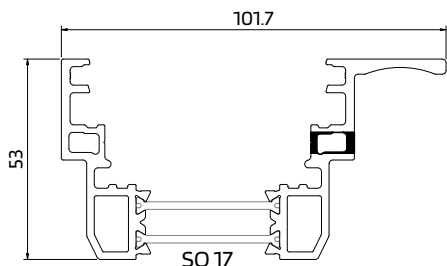
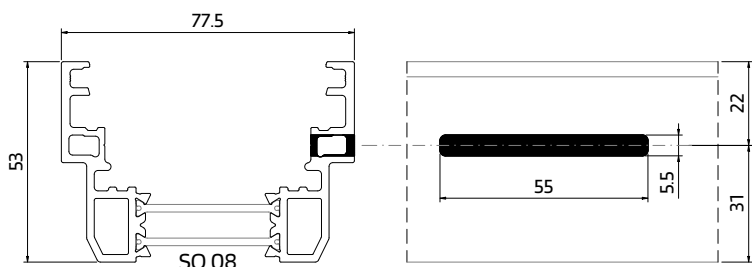
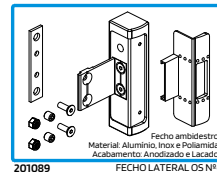

**Maquinação realizada manualmente**  
 Machining performed manually  
 Machinage réalisé à la main

**Maquinação dos perfis móveis VO 66 e VO 67.**  
 Milling of VO 66 and VO 67 movable profiles.  
 Usinage des profilés mobiles VO 66 et VO 67.

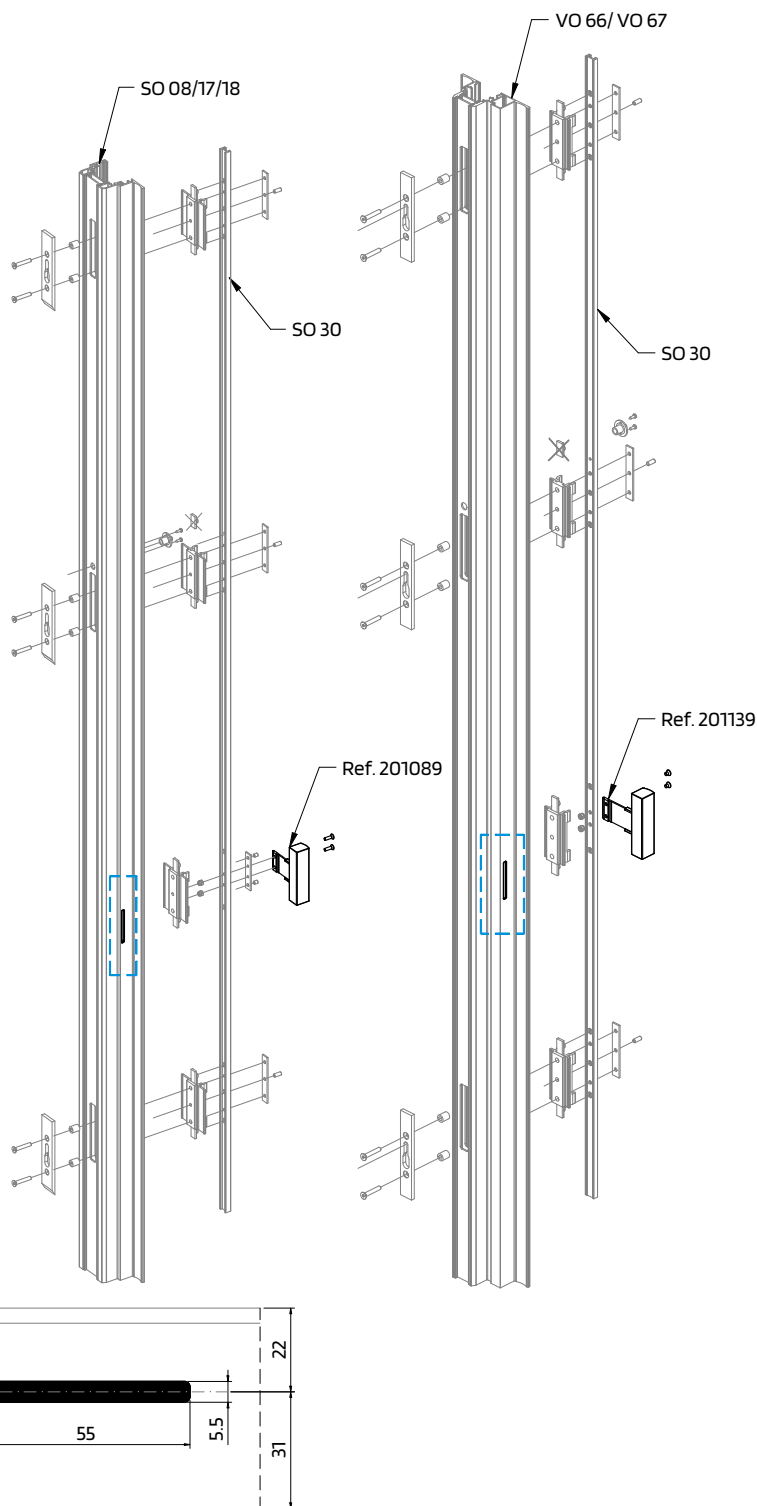
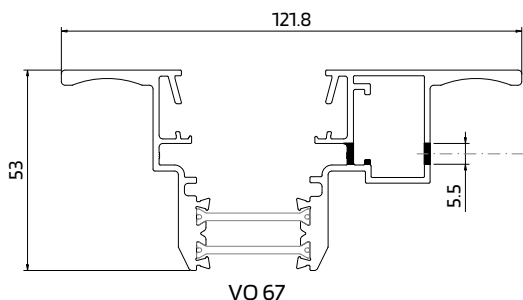
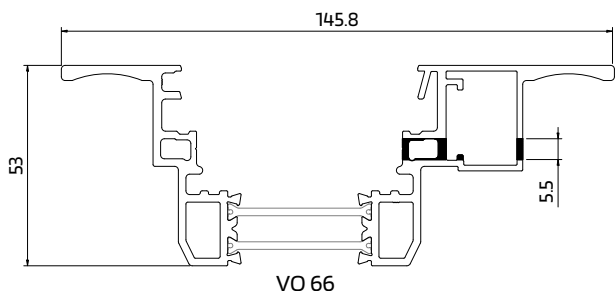
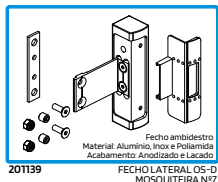

Operações do cortante OS-D/ OS-T Perimetral

Sistema OS



Maquinação do perfil SO 33.  
SO 33 profile profile machining  
Usinage du profilé SO 33.

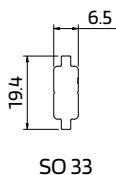

SO 33

**Operação nº2 :** realiza os furos de Ø8mm no perfil SO 33.  
**Operation No. 2:** drills Ø8mm holes in the SO 33 profile.  
**Opération n° 2 :** percer des trous de Ø8 mm dans le profilé SO 33.

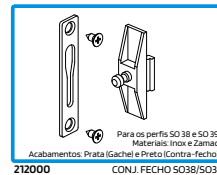
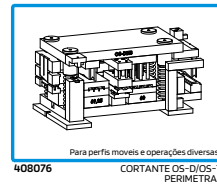
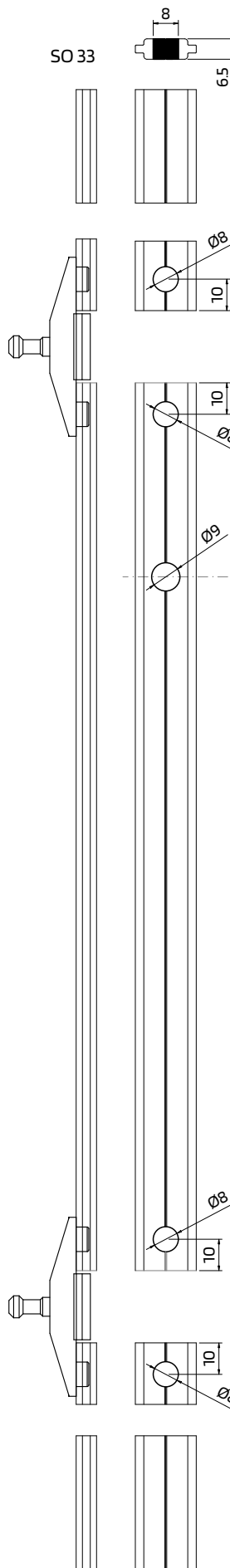
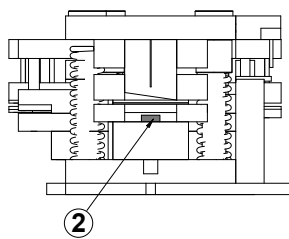
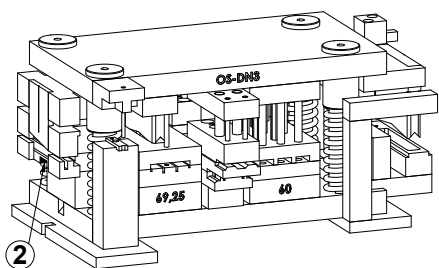

Operações do cortante OS-D/ OS-T Perimetral

Sistema OS



Maquinação dos perfis VO 18 e VO 43  
VO 18 and VO 43 profiles profile machining.  
Usinage des profilés VO 18 et VO 43

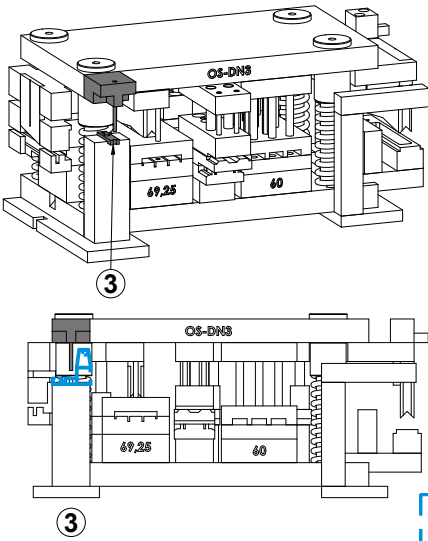

Na operação nº3, são feitos os furos de Ø3mm nos perfis VO 18 e VO 43.  
Operation 3 involves drilling 3mm diameter holes in the VO 18 and VO 43 profiles.  
Lors de l'opération n° 3, des trous de 3 mm de diamètre sont percés dans les profilés VO 18 et VO 43.

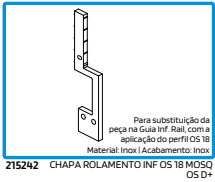
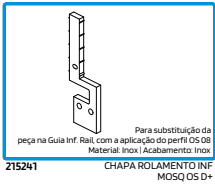
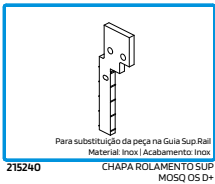
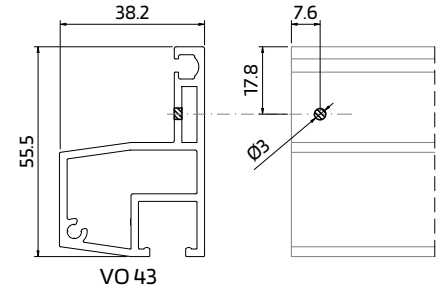
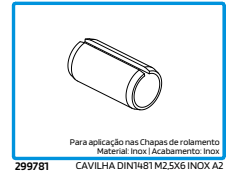
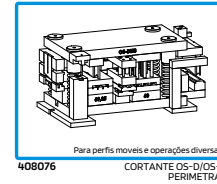
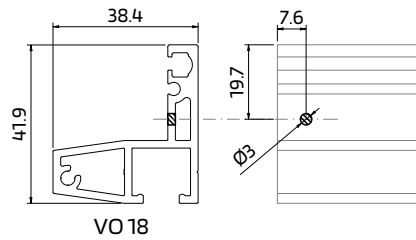

Para a aplicação cavilha  
For the application of a dowel  
Pour l'application d'un goujon

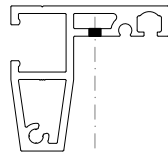

Com a utilização do perfil OS 28  
With the use of the OS 28 profile  
Avec l'utilisation du profil OS 28

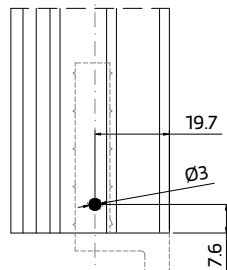

Com a utilização do perfil OS 38  
With the use of the OS 38 profile  
Avec l'utilisation du profil OS 38

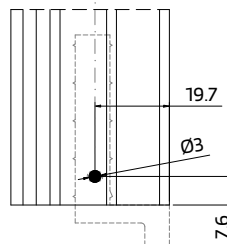

Para a aplicação cavilha  
For the application of a dowel  
Pour l'application d'un goujon

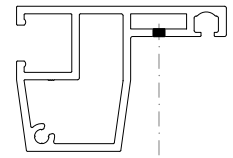

Com a utilização do perfil OS 28  
With the use of the OS 28 profile  
Avec l'utilisation du profil OS 28

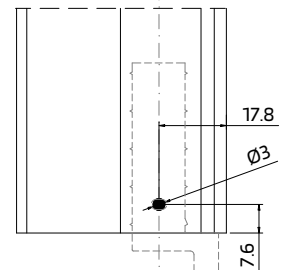

Com a utilização do perfil OS 38  
With the use of the OS 38 profile  
Avec l'utilisation du profil OS 38

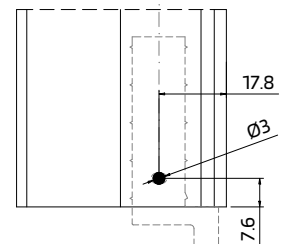

Operações do cortante OS-D/ OS-T Perimetral



Sistema OS

Maquinação do perfil SO 40.  
SO 40 profile profile machining.  
Usinage du profilé SO 40.

Antes de colocar o perfil SO 40 na **operação nº4**, marcar 69.25mm no perfil, desde o centro do rasgo de 82.3mm.

Before placing the SO 40 profile in **operation 4**, mark 69.25 mm on the profile, measured from the centre of the 82.3 mm slot.

Avant de poser le profilé SO 40 lors de l'**opération nº 4**, marquer le profilé à 69.25mm à partir du centre de l'encoche de 82.3mm.

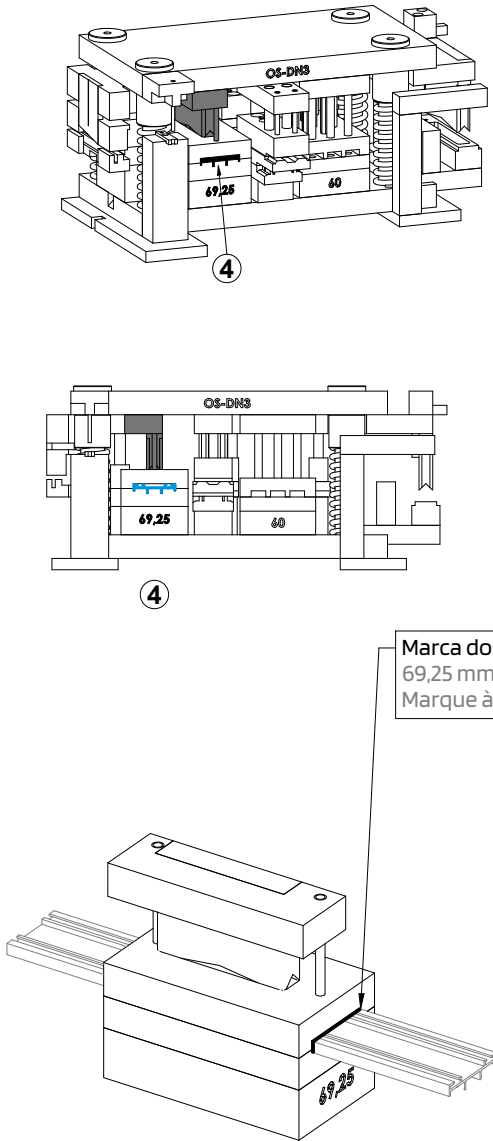
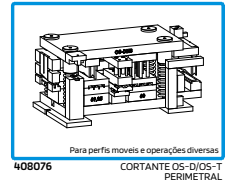

Marca dos 69,25mm.  
69,25 mm mark.  
Marque à 69,25 mm.

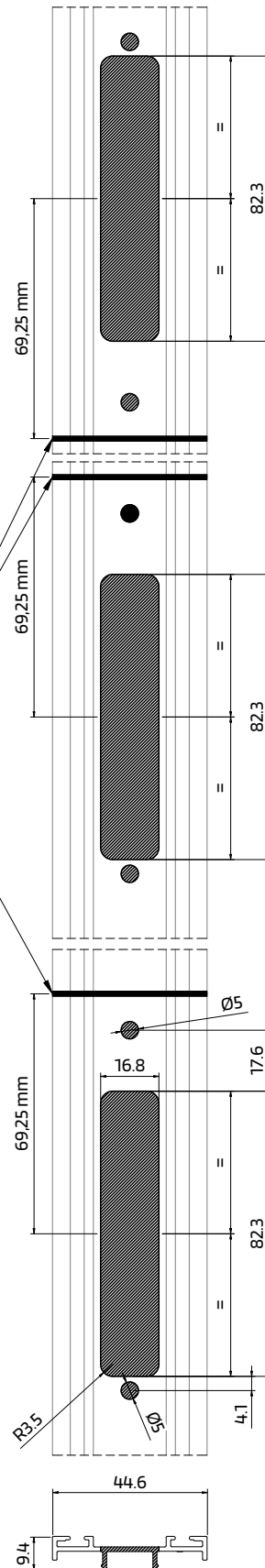

SO 40  
Perfil testa fechadura  
Lock plate profile  
Profilé plaque pour serrure

Operações do cortante OS-D/ OS-T Perimetral

Sistema OS



Maquinação do perfil SO 30.  
SO 30 profile machining  
Usinage du profilé SO 30.

Antes de colocar o perfil SO 30 na **operação nº6**, marcar 60mm no perfil, desde o centro do rasgo de 94.3mm.  
Before placing the SO 30 profile in **operation 6**, mark 60mm on the profile, measured from the centre of the 94.3mm slot.  
Avant de poser le profilé SO 30 lors de l'**opération nº 6**, marquer le profilé à 60 mm à partir du centre de l'encoche de 94.3mm.

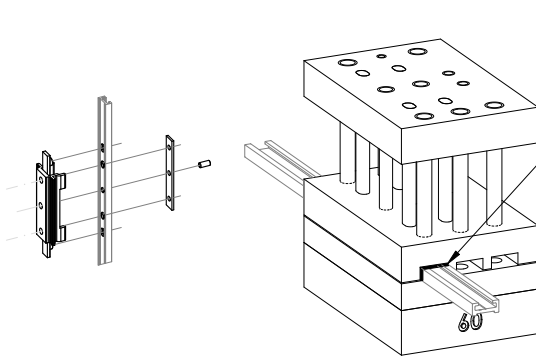
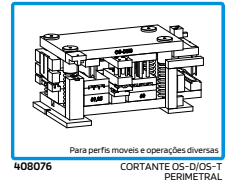
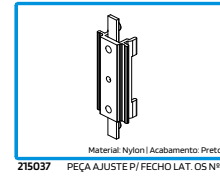
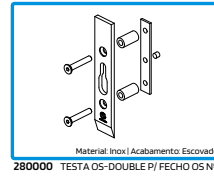

Marca dos 60mm.  
60 mm mark.  
Marque à 60 mm.

Operação nº6  
Operation nº6  
Opération nº6

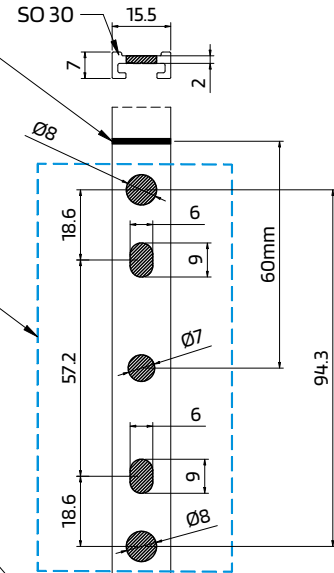

Direcção da maquinação  
Machining direction | Direction de l'usinage

Antes de colocar o perfil SO 30 na **operação nº6a**, marcar 60mm no perfil, desde o centro do rasgo de 97.2mm.  
Before placing the SO 30 profile in **operation 6a**, mark 60mm on the profile, measured from the centre of the 97.2mm slot.  
Avant de poser le profilé SO 30 lors de l'**opération nº 6a**, marquer le profilé à 60 mm à partir du centre de l'encoche de 97.2mm.

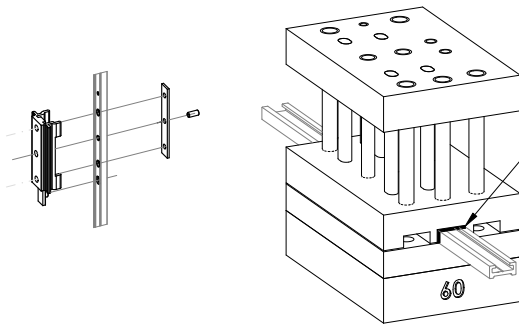

Marca dos 60mm.  
60 mm mark.  
Marque à 60 mm.

Operação nº6a  
Operation nº6a  
Opération nº6a

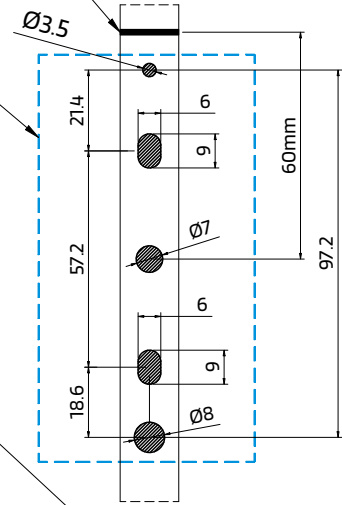

Direcção da maquinação  
Machining direction | Direction de l'usinage

Antes de colocar o perfil SO 30 na **operação nº6b**, marcar 60mm no perfil, desde o centro do rasgo de 94.5mm.  
Before placing the SO 30 profile in **operation 6b**, mark 60mm on the profile, measured from the centre of the 94.5mm slot.  
Avant de poser le profilé SO 30 lors de l'**opération nº 6b**, marquer le profilé à 60 mm à partir du centre de l'encoche de 94.5mm.

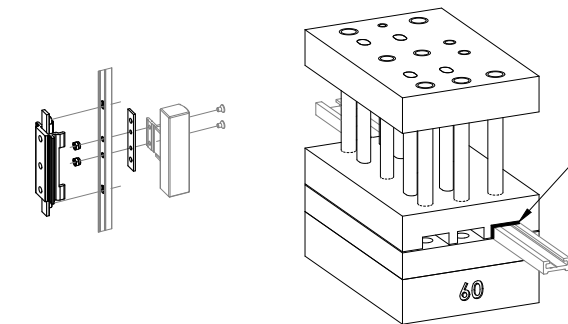

Marca dos 60mm.  
60 mm mark.  
Marque à 60 mm.

Operação nº6b  
Operation nº6b  
Opération nº6b

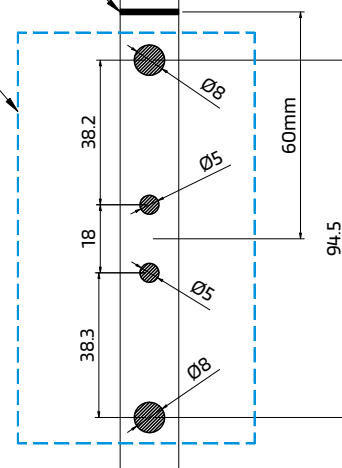

Direcção da maquinação  
Machining direction | Direction de l'usinage

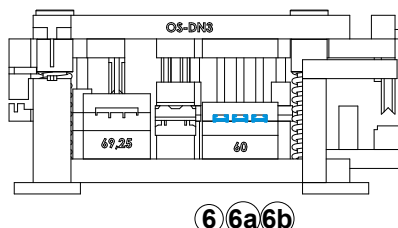
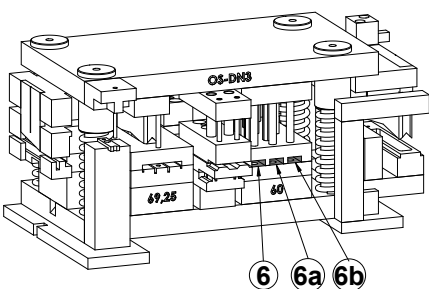

6 6a 6b

6 6a 6b

Operações do cortante OS-D/ OS-T Perimetral

Sistema OS



Maquinação dos perfis SO 64, SO 65 e SO 66.  
SO 64, SO 65 and SO 66 profiles machining.  
Usinage des profilés SO 64, SO 65 et SO 66.

Maquinação realizada no Cortante  
Machining performed on Punching tool  
Usinage réalisée dans l'Outil

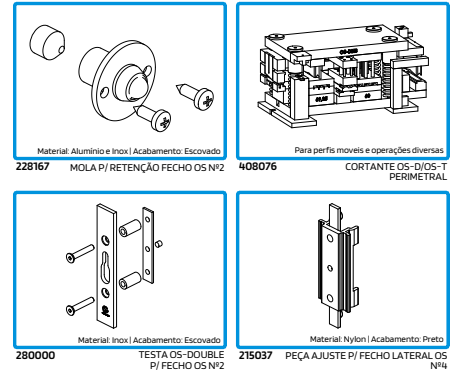
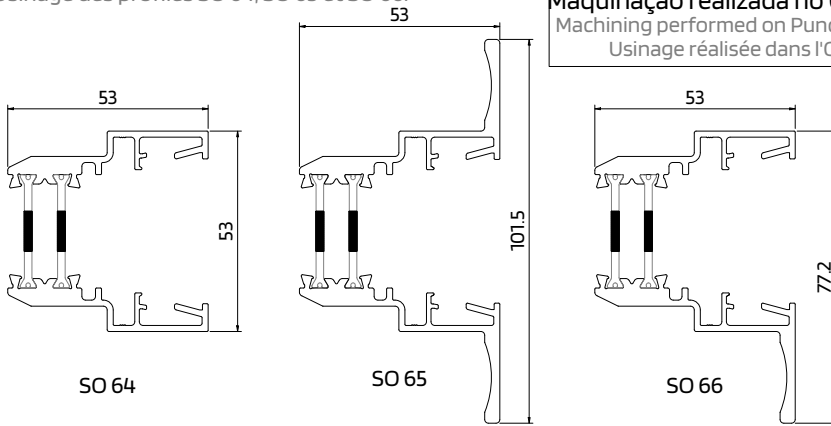

Maquinação dos perfis móveis SO 08, SO 17 e SO 18.  
SO 08, SO 17 and SO 18 profiles machining.  
Usinage des profilés mobiles SO 08, SO 17 et SO 18.

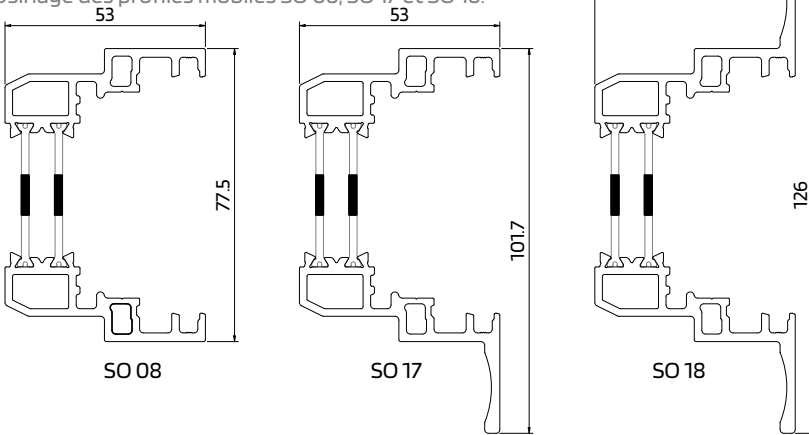

Operação nº7  
Operation nº7  
Opération nº7

Operação nº7a  
Operation nº7a  
Opération nº7a

Operação nº7  
Operation nº7  
Opération nº7

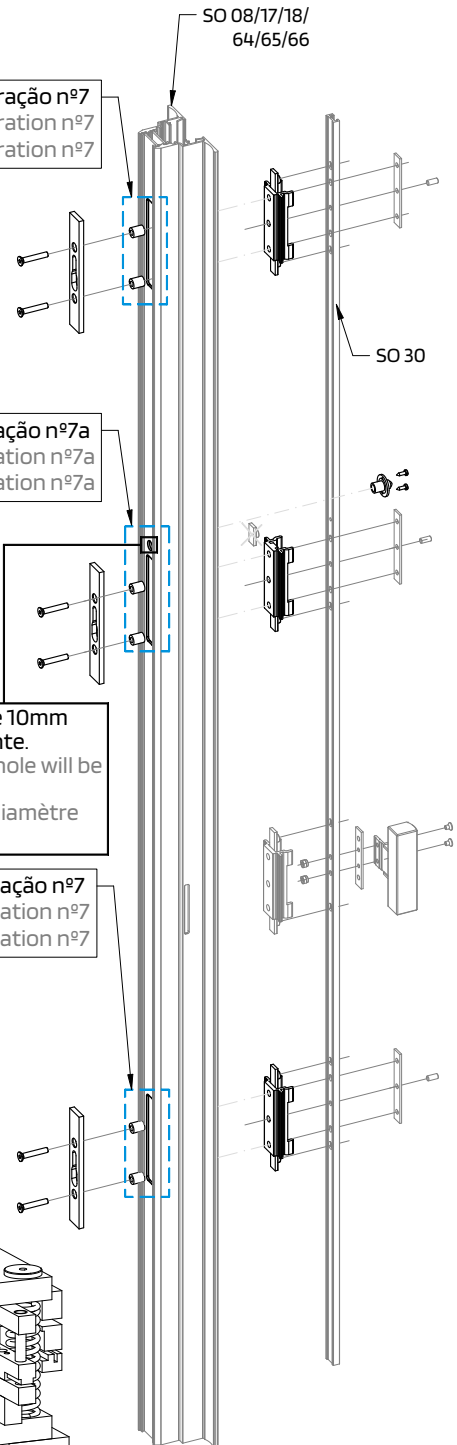

Marcar primeiro o centro do rasgo nos perfis para depois se maquina nas operações nº7 e 7a.  
First mark the centre of the slot on the profiles, then machine them in operations 7 and 7a  
Marquer d'abord le centre de la fente sur les profilés, puis procéder à l'usinage lors de l'opérations nº7 et 7a.

O furo de diametro de 10mm será feito manualmente.  
The 10 mm diameter hole will be drilled by hand.  
Le trou de 10 mm de diamètre sera percé à la main.

Para fazer os rasgos na operação nº7, desativar a ferramenta da operação 7a.  
To make the cuts in operation 7, deactivate the tool for operation 7a.  
Pour réaliser les entailles lors de l'opération nº 7, désactivez l'outil de l'opération 7a.

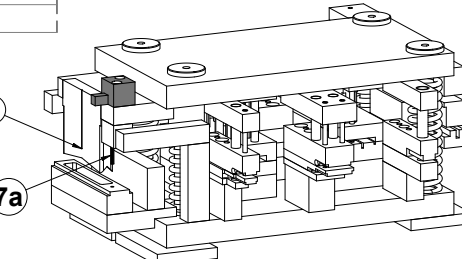
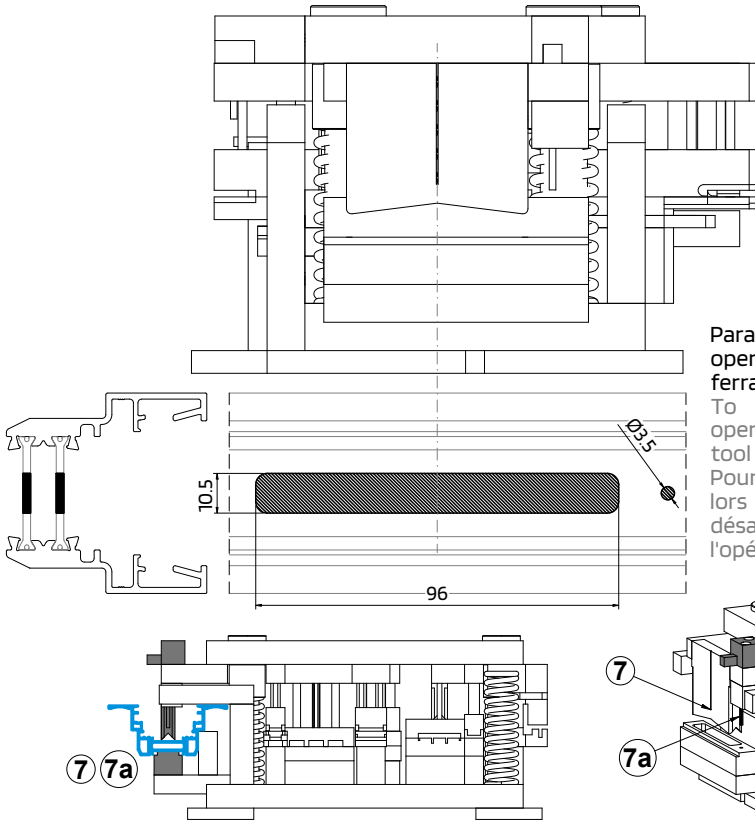

Operações do cortante OS-D/ OS-T Perimetral

Sistema OS



**Maquinação dos perfis móveis SO 64, SO 65, SO 66 e VO 67.**  
 SO 64, SO 65, SO 66 and VO 67 profiles machining.  
 Usinage des profilés SO 64, SO 65, SO 66 et VO 67.

**OS-SIMPLE e DOUBLE - Linha Standard**  
 OS-SIMPLE and DOUBLE - Standard line  
 OS-SIMPLE et DOUBLE - Ligne Standard

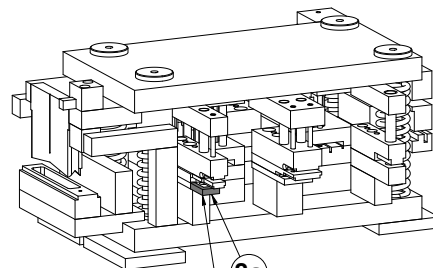
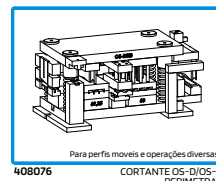
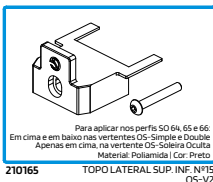
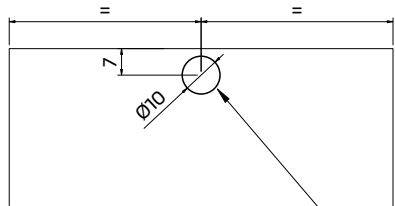

**Operação nº8a | Operation No. 8a | Opération n° 8a**  
 Em cima e em baixo e na poliamida exterior.  
 On the top and bottom and on the outer polyamide.  
 En haut, en bas et sur la polyamide extérieure.

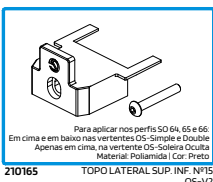
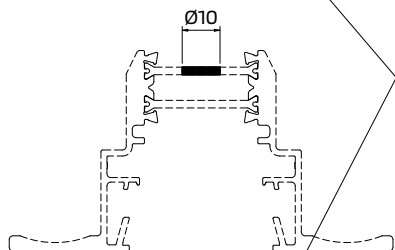

Para realizar esta operação, colocar a peça de enchimento de 24.6mmx29.7mm.  
 For this operation, insert the 24.6mmx29.7mm filling piece.  
 Pour effectuer cette opération, placez la pièce de remplissage de 24.6mmx29.7mm.

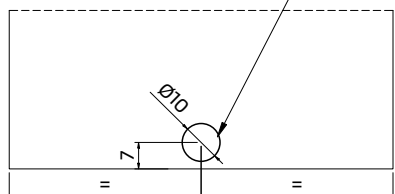
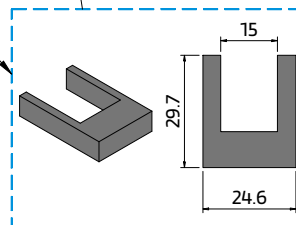

**OS-SIMPLE e DOUBLE - Soleira oculta**  
 OS-SIMPLE and DOUBLE - Concealed sill  
 OS-SIMPLE et OS-DOUBLE - Seuil cachée

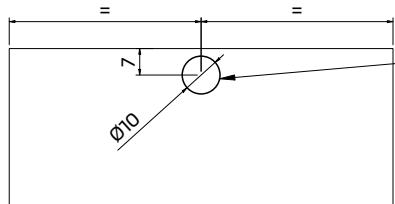

**Operação nº8a | Operation No. 8a | Opération n° 8a**  
 Em cima e em baixo e na poliamida exterior.  
 On the top and bottom and on the outer polyamide.  
 En haut, en bas et sur la polyamide extérieure.

**Operação nº8 | Operation No. 8 | Opération n° 8**  
 Apenas em baixo e na poliamida interior  
 Only at the bottom and on the inner polyamide  
 Uniquement en bas et dans le polyamide intérieur

**Operação nº8a | Operation No. 8a | Opération n° 8a**  
 Apenas em baixo e na poliamida exterior  
 Only on the bottom and on the outer polyamide  
 Uniquement en bas et dans le polyamide extérieure

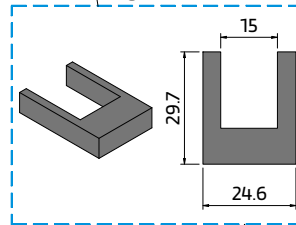
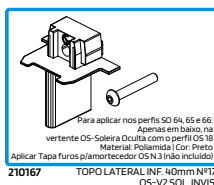
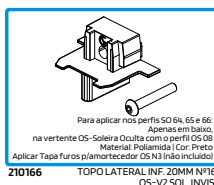

Para realizar esta operação, colocar a peça de enchimento de 24.6mmx29.7mm.  
 For this operation, insert the 24.6mmx29.7mm filling piece.  
 Pour effectuer cette opération, placez la pièce de remplissage de 24.6mmx29.7mm.

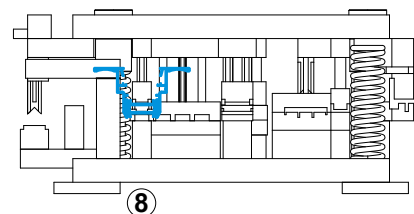
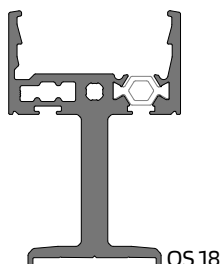
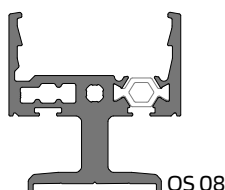
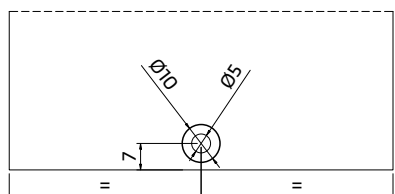

Operações do cortante OS-D/ OS-T Perimetral

Sistema OS



**Maquinação do perfil SO 03.**  
SO 03 profile profile machining  
Usinage du profilé SO 03.

**OS-SIMPLE e DOUBLE - Linha Standard**  
OS-SIMPLE and DOUBLE - Standard line  
OS-SIMPLE et DOUBLE - Ligne Standard

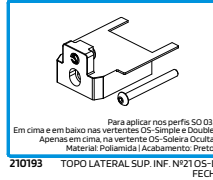
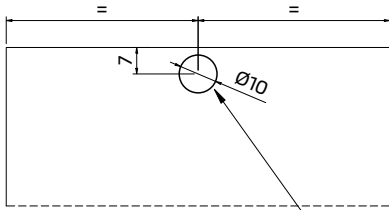

**Operação nº8a | Operation No. 8a | Opération n° 8a**  
Em cima e em baixo e na poliamida exterior.  
On the top and bottom and on the outer polyamide.  
En haut, en bas et sur la polyamide extérieure.

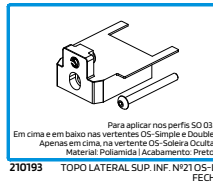
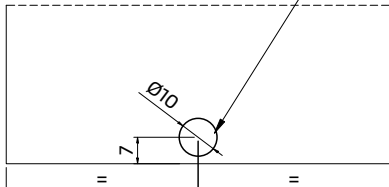
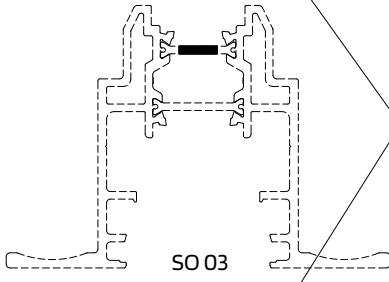

**OS-SIMPLE e DOUBLE - Soleira oculta**  
OS-SIMPLE and DOUBLE - Concealed sill  
OS-SIMPLE et OS-DOUBLE - Seuil cachée

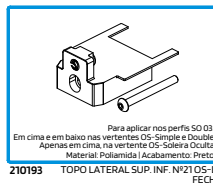
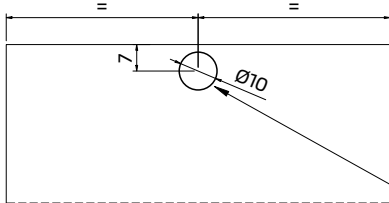

**Operação nº8a | Operation No. 8a | Opération n° 8a**  
Em cima e em baixo e na poliamida exterior.  
On the top and bottom and on the outer polyamide.  
En haut, en bas et sur la polyamide extérieure.

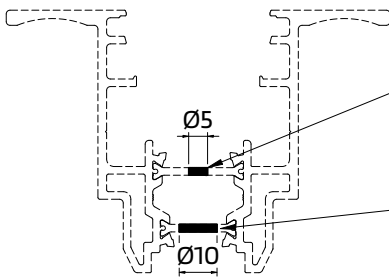

**Operação nº8 | Operation No. 8 | Opération n° 8**  
Apenas em baixo e na poliamida interior  
Uniquement en bas et dans le polyamide intérieur

**Operação nº8a | Operation No. 8a | Opération n° 8a**  
Apenas em baixo e na poliamida exterior  
Uniquement en bas et dans le polyamide extérieur

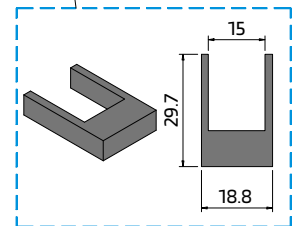
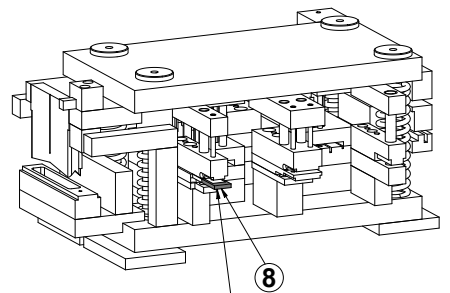
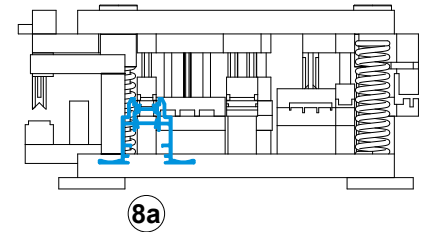
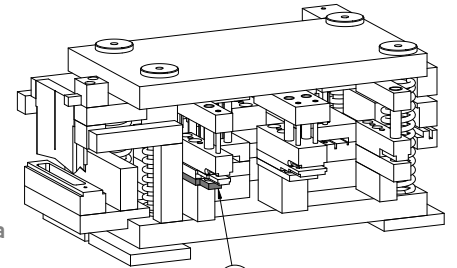
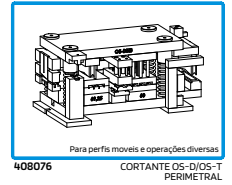
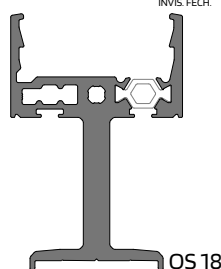
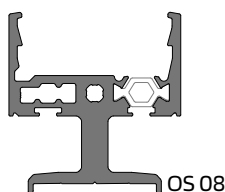
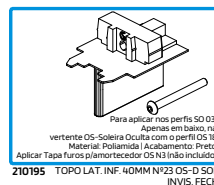
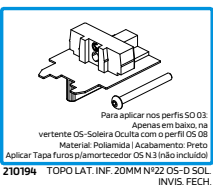
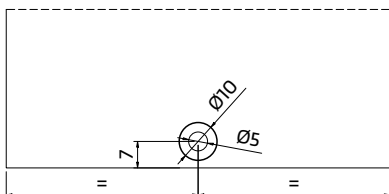

Para realizar esta operação, colocar a peça de enchimento de 18.8mmx29.7mm.  
For this operation, insert the 18.8mmx29.7mm filling piece.  
Pour effectuer cette opération, placez la pièce de remplissage de 18.8mmx29.7mm.

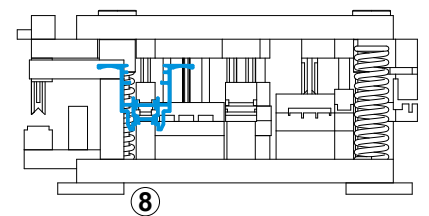

Operações do cortante OS-D/ OS-T Perimetral

Sistema OS



**Maquinação dos perfis SO 08, SO 17, SO 18 e VO 66.**  
 SO 08, SO 17, SO 18 and VO 66 profiles machining.  
 Usinage des profilés SO 08, SO 17, SO 18 et VO 66.

**OS-TRIPLE - Linha Standard**  
 OS-TRIPLE - Standard line  
 OS-TRIPLE - Ligne Standard

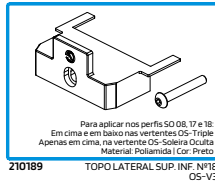
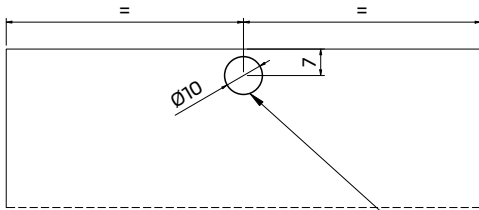

**Operação nº8a | Operation No. 8a | Opération n° 8a**  
 Em cima e em baixo e na poliamida exterior.  
 On the top and bottom and on the outer polyamide.  
 En haut, en bas et sur la polyamide extérieure.

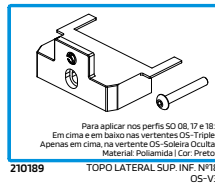
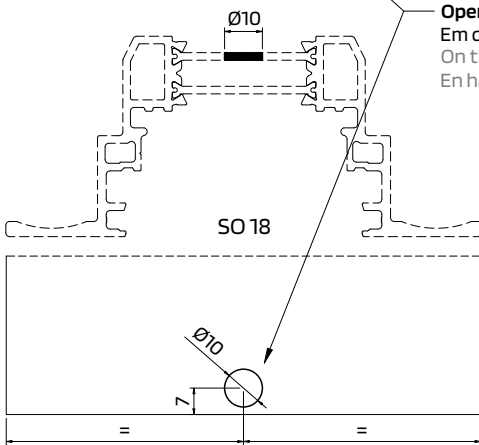

Para realizar esta operação, colocar a peça de enchimento de 32.8mmx29.7mm.  
 For this operation, insert the 32.8mmx29.7mm filling piece.  
 Pour effectuer cette opération, placez la pièce de remplissage de 32.8mmx29.7mm.

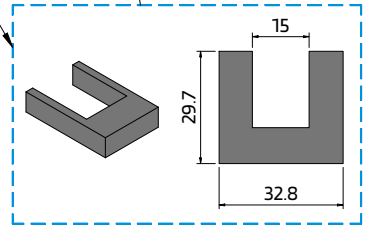

**OS-TRIPLE vertente Soleira oculta.**  
 OS-TRIPLE series Concealed threshold.  
 OS-TRIPLE, version à seuil encastré.

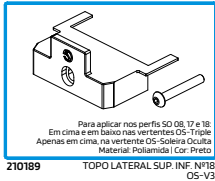
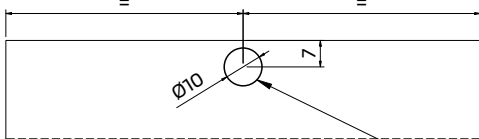

**Operação nº8a | Operation No. 8a | Opération n° 8a**  
 Apenas em cima e na poliamida exterior.  
 only on the top and on the outer polyamide.  
 Seulement sur le dessus et sur la polyamide extérieur

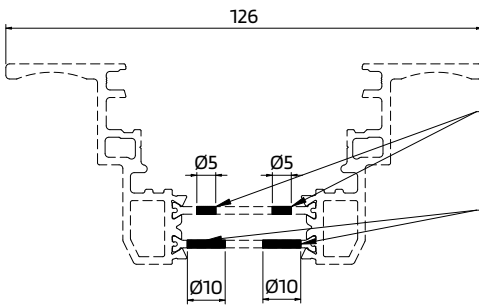

**Operação nº9 | Operation No. 9 | Opération n° 9**  
 Apenas em baixo e na poliamida interior  
 Only at the bottom and on the inner polyamide  
 Uniquement en bas et dans le polyamide intérieur

**Operação nº9a | Operation No. 9a | Opération n° 9a**  
 Apenas em baixo e na poliamida exterior  
 Only on the bottom and on the outer polyamide  
 Uniquement en bas et dans le polyamide extérieur.

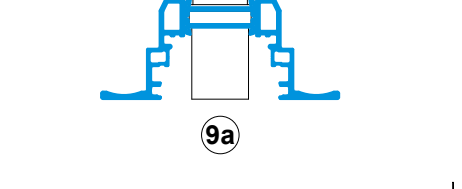
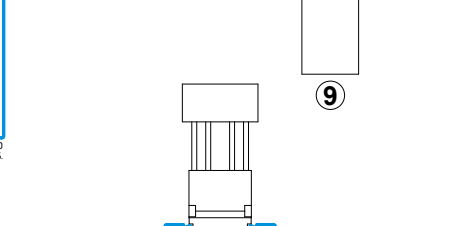
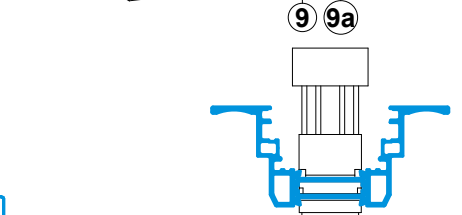
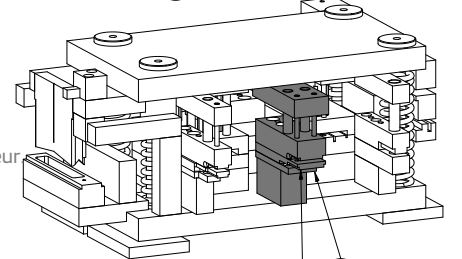
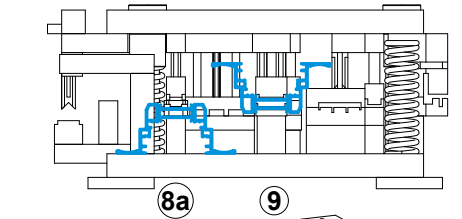
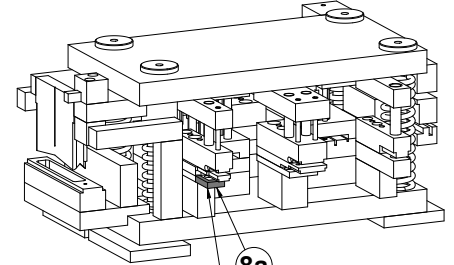
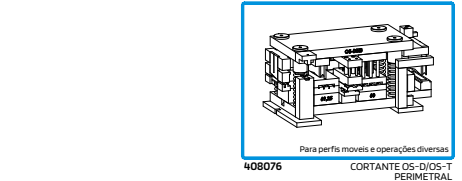
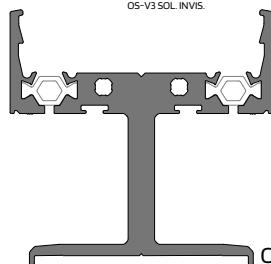
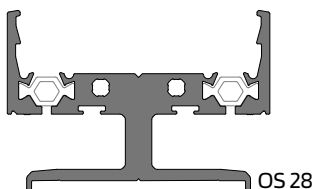
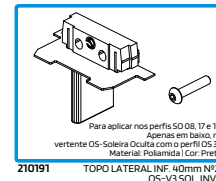
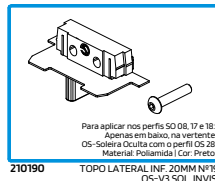
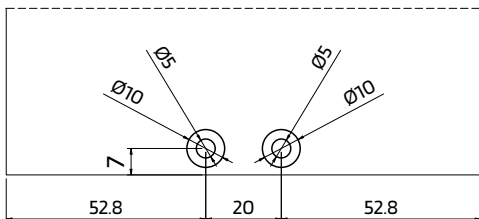

Operações do cortante OS-D/ OS-T Perimetral

Sistema OS



Maquinação do perfil VO 52  
VO 52 profile machining  
Usinage du profilé VO 52  
OS-TRIPLE - Linha Standard  
OS-TRIPLE - Standard line  
OS-TRIPLE - Ligne Standard

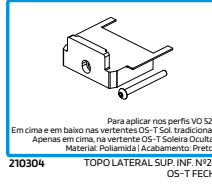
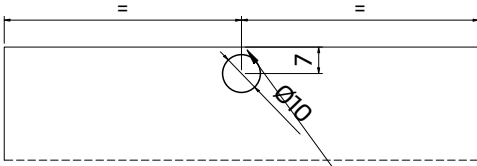
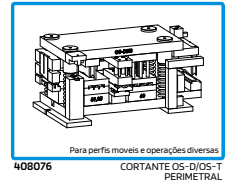

**Operação nº8a | Operation No. 8a | Opération n° 8a**  
Em cima e em baixo e na poliamida exterior.  
On the top and bottom and on the outer polyamide.  
En haut, en bas et sur la polyamide extérieure.

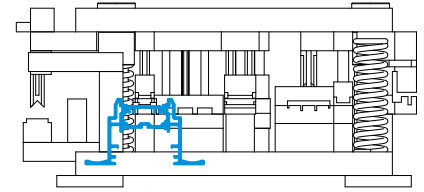

8a

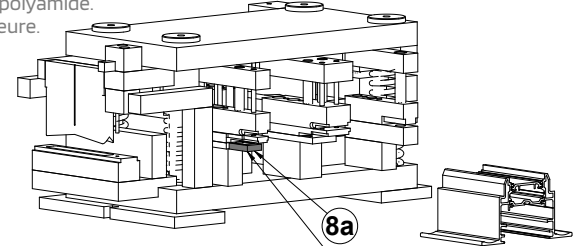
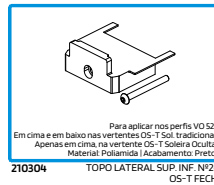
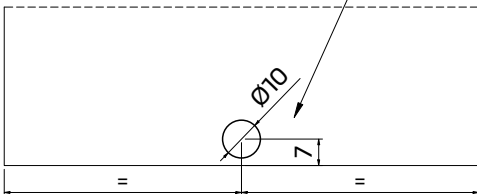
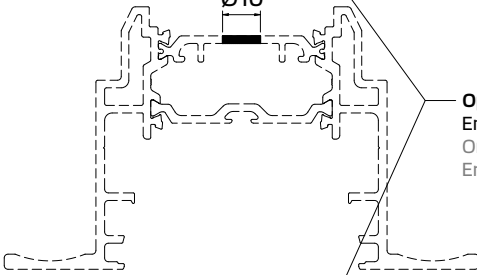

Para realizar esta operação, colocar a peça de enchimento de 19.8mmx29.7mm.  
For this operation, insert the 19.8mmx29.7mm filling piece.  
Pour effectuer cette opération, placez la pièce de remplissage de 19.8mmx29.7mm.

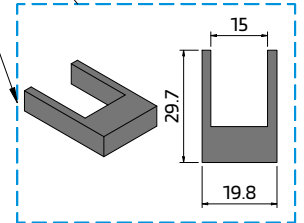

OS-TRIPLE - Soleira oculta  
OS-TRIPLE - Concealed threshold  
OS-TRIPLE - Seuil cachée

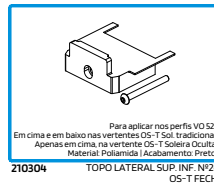
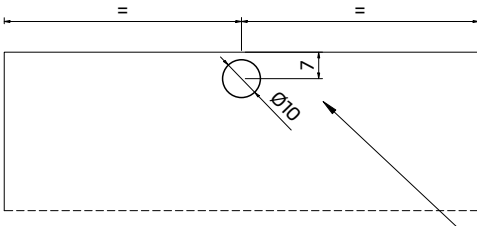

**Operação nº8a | Operation No. 8a | Opération n° 8a**  
Apenas em cima e na poliamida exterior.  
Only on the top and on the outer polyamide.  
Seulement sur le dessus et sur la polyamide extérieure.

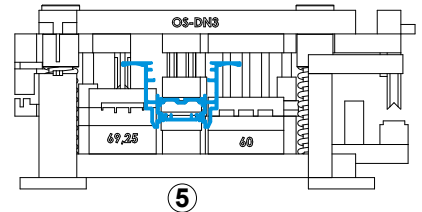

5

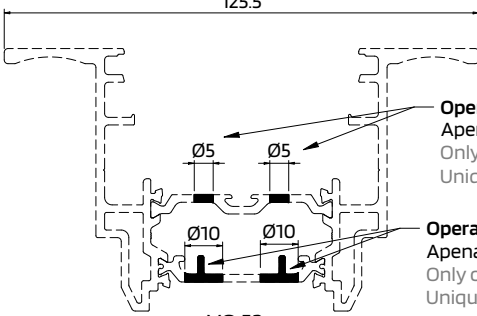

**Operação nº5 | Operation No. 5 | Opération n° 5**  
Apenas em baixo e na poliamida interior  
Only at the bottom and on the inner polyamide  
Uniquement en bas et dans le polyamide intérieur

**Operação nº5a | Operation No. 5a | Opération n° 5a**  
Apenas em baixo e na poliamida exterior  
Only on the bottom and on the outer polyamide  
Uniquement en bas et dans le polyamide extérieure

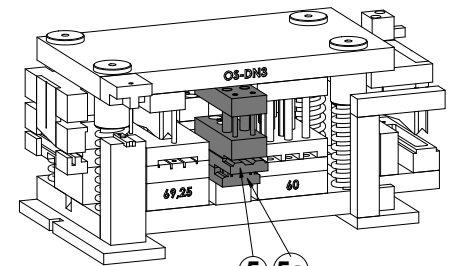

5 5a

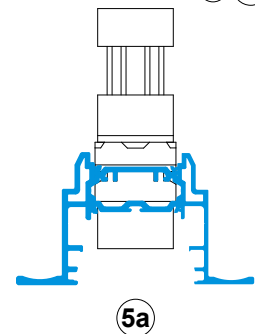
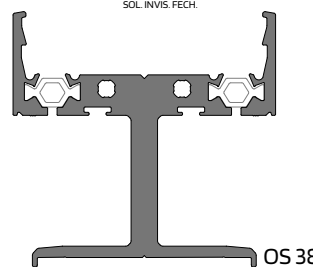
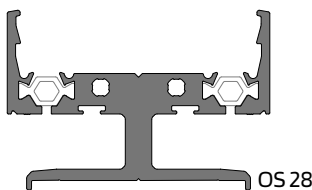
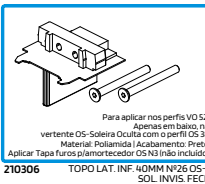
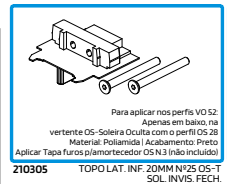
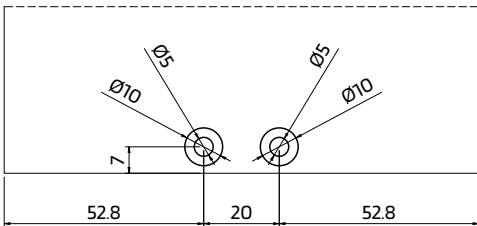

5a

Operações do cortante OS-D/ OS-T Perimetral



Sistema OS

Maquinação dos perfis SO 38, SO 39 e SO 53  
 SO 38, SO 39 and SO 53 profiles machining  
 Usinage des profilés SO 38, SO 39 et SO 53  
**OS-SIMPLE e DOUBLE - Linha Standard**  
 OS-SIMPLE and DOUBLE - Standard line  
 OS-SIMPLE et DOUBLE - Ligne Standard

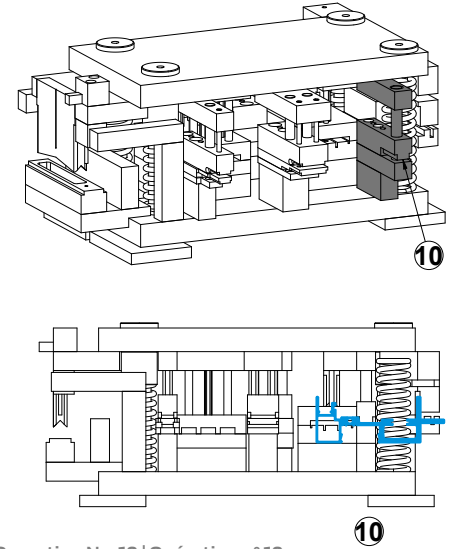
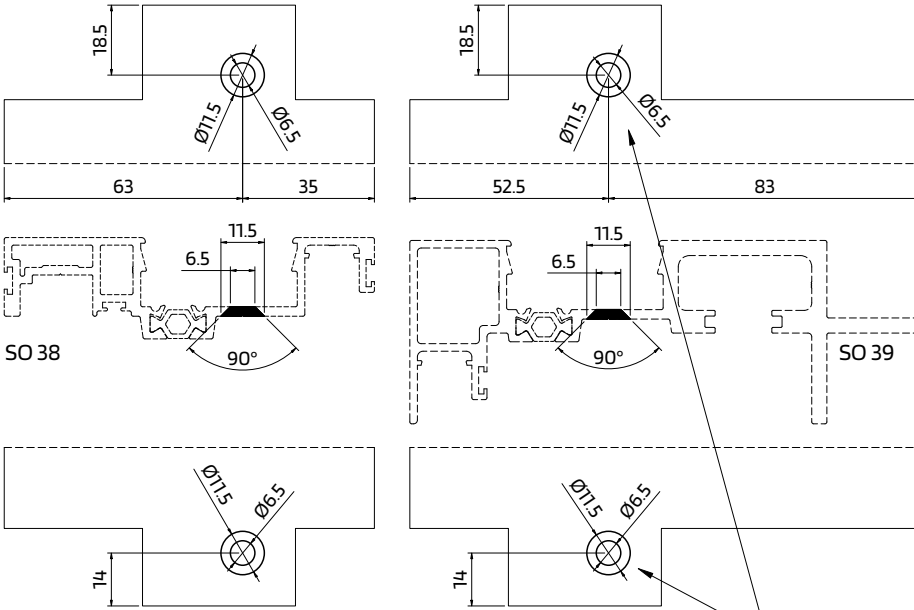
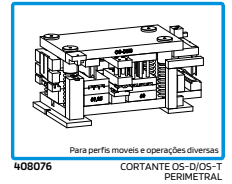

**Operação nº10 | Operation No. 10 | Opération n° 10**  
 Em cima e em baixo  
 On the top and bottom | En haut et en bas

**OS-SIMPLE e DOUBLE - Soleira oculta**  
 OS-SIMPLE and DOUBLE - Concealed sill  
 OS-SIMPLE et OS-DOUBLE - Seuil caché

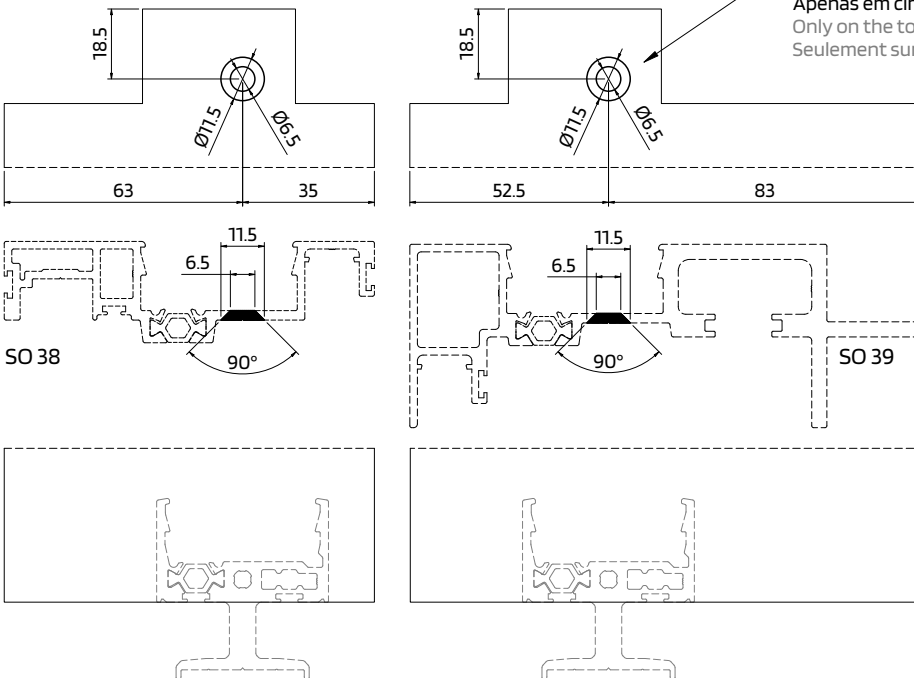

**Operação nº10 | Operation No. 10 | Opération n° 10**  
 Apenas em cima  
 Only on the top  
 Seulement sur le dessus

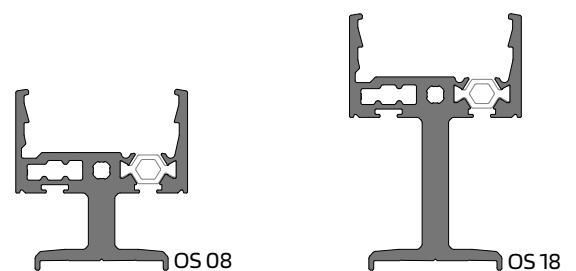

Operações do cortante OS-D/ OS-T Perimetral

Sistema OS



Maquinação dos perfis SO 77, e SO 79  
 SO 77, and SO 79 profiles machining  
 Usinage des profilés SO 77 et SO 79  
**OS-TRIPLE - Linha Standard**  
 OS-TRIPLE - Standard line  
 OS-TRIPLE - Ligne Standard

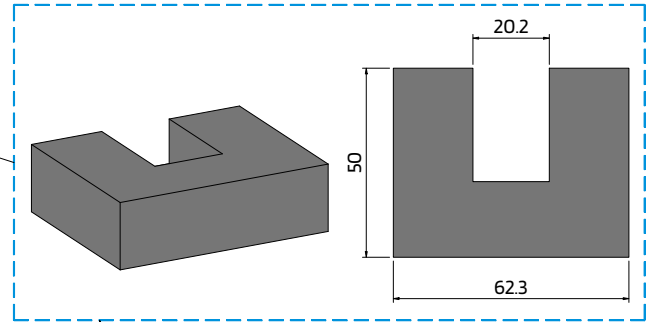
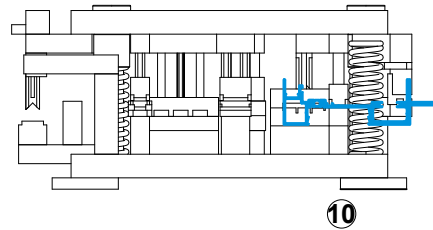
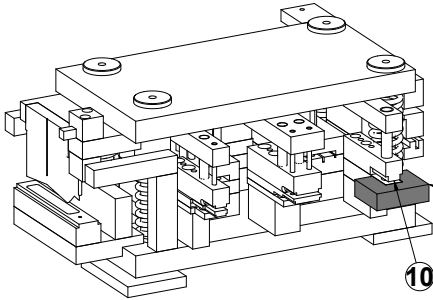
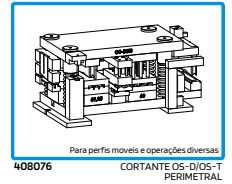

Para realizar esta operação, colocar a peça de enchimento de 62.3mmx50mm.  
 For this operation, insert the 62.3mmx50mm filling piece.  
 Pour effectuer cette opération, placez la pièce de remplissage de 62.3mmx50mm.

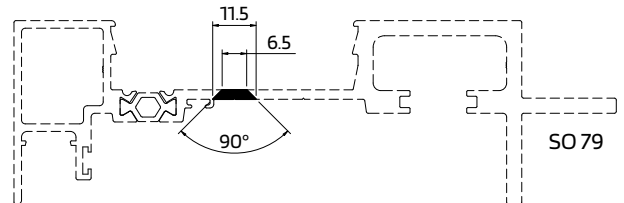
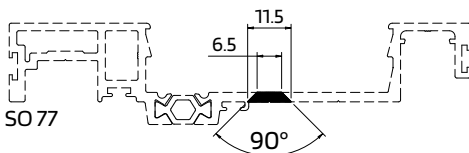
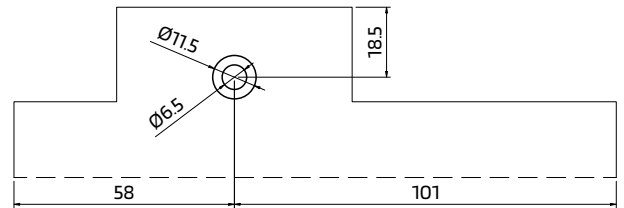
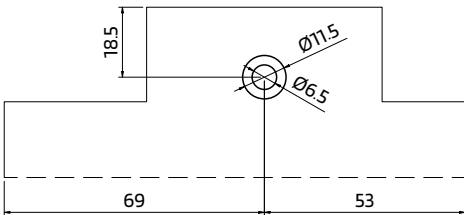

Fresagem inferior - opção com furo  
 Bottom milling - with hole option | Fraisage inférieur - option avec trou

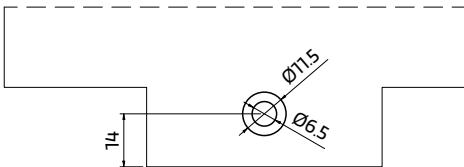

Fresagem inferior - opção com furo  
 Bottom milling - with hole option | Fraisage inférieur - option avec trou

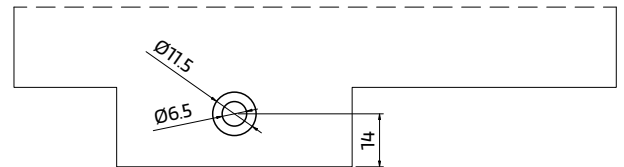

Fresagem inferior - opção sem furo  
 Bottom milling - without hole option | Fraisage inférieur - option sans trou



Fresagem inferior - opção sem furo  
 Bottom milling - without hole option | Fraisage inférieur - option sans trou

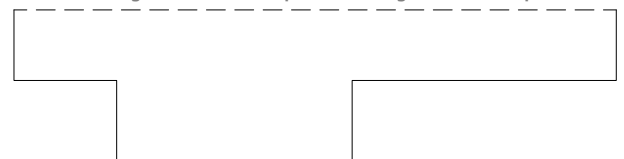

Operações do cortante OS-D/ OS-T Perimetral

Sistema OS



Maquinação dos perfis SO 77, e SO 79.  
 Machining of profiles SO 77, and SO 79.  
 Usinage des profilés SO 77 et SO 79.

OS-TRIPLE - Soleira oculta  
 OS-TRIPLE - Concealed threshold  
 OS-TRIPLE - Seuil cachée

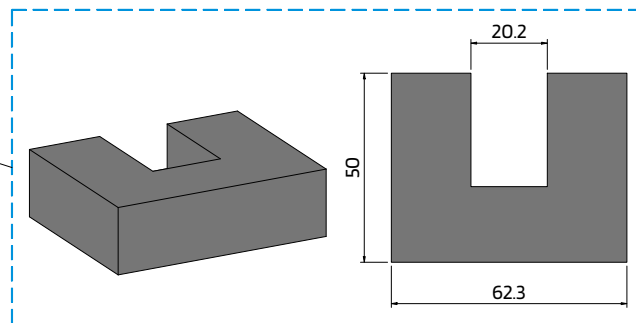
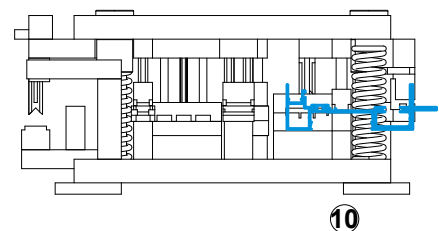
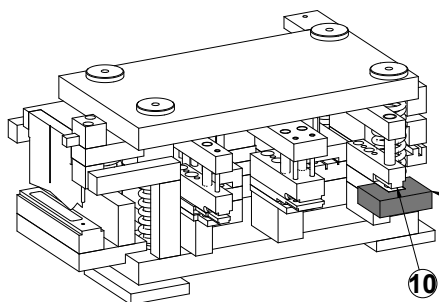
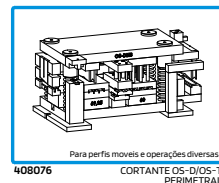

Para realizar esta operação, colocar a peça de enchimento de 62.3mmx50mm.  
 For this operation, insert the 62.3mmx50mm filling piece.  
 Pour effectuer cette opération, placez la pièce de remplissage de 62.3mmx50mm.

