

OS-Double⁺

sistema minimalista de correr com corte térmico para vidro simples e duplo
minimalist sliding system with thermal break for simple and double glazing
système minimaliste coulissant à rupture de pont thermique pour simple et double vitrage



Casa JT | Madeira | Mayer & Selders Arquitectos

CATÁLOGO TÉCNICO

TECHNICAL CATALOG | CATALOGUE TECHNIQUE





Casa em Travanca | Nelson Resende, Arq. | Fotografia FG+SG

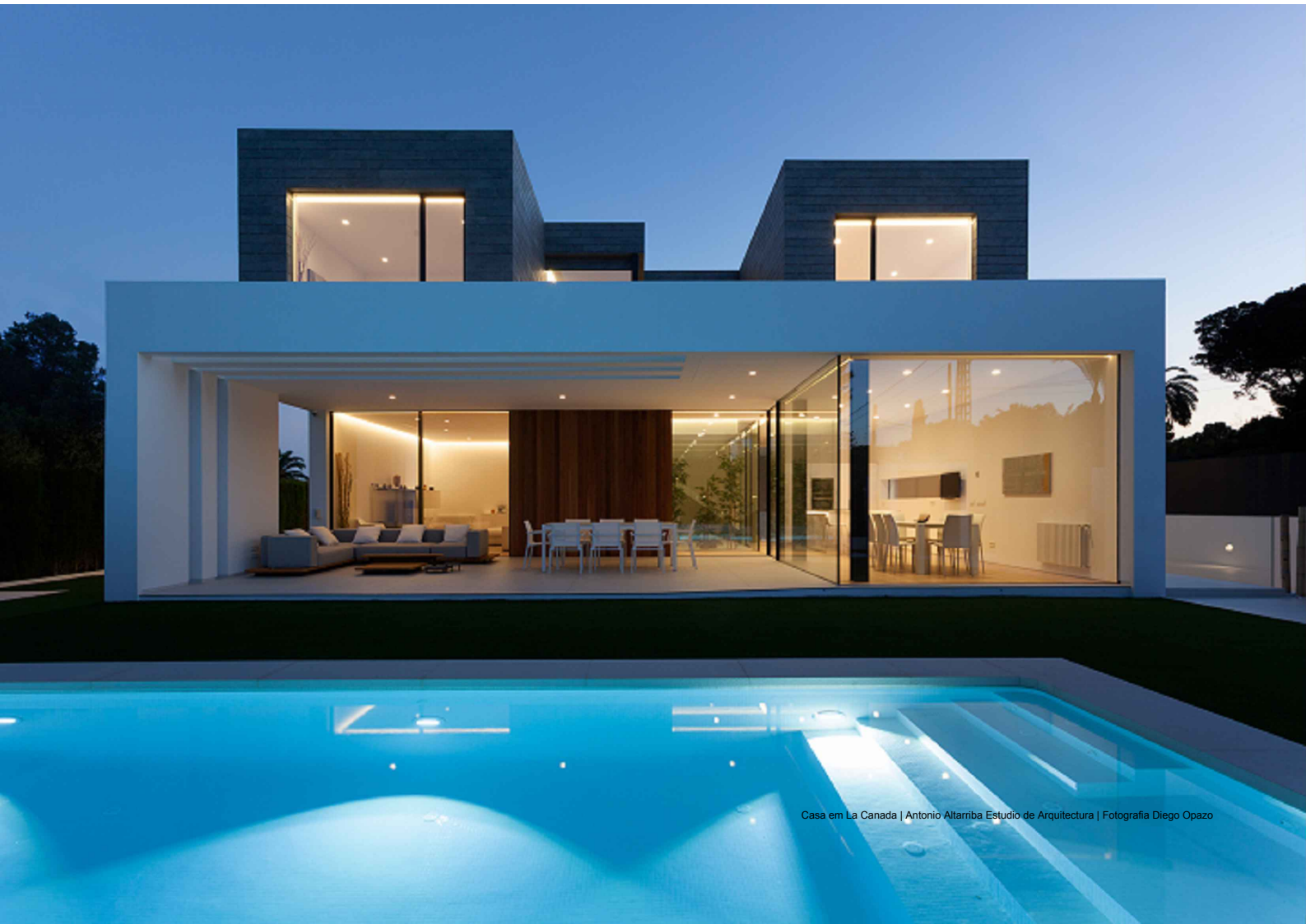

Casa em La Canada | Antonio Altarriba Estudio de Arquitectura | Fotografia Diego Opazo

I

ÍNDICE

TABLE OF CONTENTS | TABLE DE MATIÈRES

Apresentação Presentation Présentation	I
Listagem de perfis Profiles list Liste des profilés	II
Listagem de acessórios Accessories list Liste d'accessoires	III
Tipologias e mapas de quantidades - OS-D⁺ Soleira Tradicional Typologies and quantity maps - OS-D ⁺ Classic Sill Typologies et cartes des quantités - OS-D+ Seuil Classic	IV
Tipologias e mapas de quantidades - OS-D⁺ Soleira Oculta Typologies and quantity maps - OS-D ⁺ Concealed Sill Typologies et cartes des quantités - OS-D+ Seuil Caché	V
Maquinações, cortes e fresagens Machinings, cuts and millings Usinages, coupes et fraisages	VI
Montagens Assemblies Assamblages	VII
Pré-aros Pre-frames Pré-cadres	VIII
Soleiras e Caleiras Sills and Drainage channels Seuils et Gouttièrres de vidanges	IX
Anotações Notes Remarques	X

sistema minimalista de correr com corte térmico para vidro simples e duplo
minimalist sliding system with thermal break for simple and double glazing
système minimaliste coulissant à rupture de pont thermique pour simple et double vitrage



Concebido especialmente para vãos de grandes dimensões, o sistema minimalista de correr OS surge como resposta às novas tendências arquitetónicas que procuram conjugar o máximo de transparência com o mínimo de vista estrutural.

The minimalist sliding system rose as an answer to new architectural trends intending to combine the maximum transparency with the minimum structural view.

Spécialement conçu pour les grandes portées le système minimal coulissant apporte une solution aux nouvelles tendances architecturales qui cherchent à conjuguer le maximum de transparence avec une vue structurelle minimale.

OS-simple

OS-double⁺

APRESENTAÇÃO PRESENTATION PRÉSENTATION	reta straight droite	
DIMENSÕES DIMENSIONS DIMENSIONS	aros fixos fixed frames cadre dormant 53mm 120.6mm 188.2mm 255.8mm aros móveis mobile frames cadre ouvrant 46mm 71mm 96mm aros centrais middle profiles centres 64mm 89mm 100mm 110mm 118mm vista lateral lateral view vue latérale 30mm vista central central view vue centrale 20mm vistas superior e inferior upper and lower sights vues supérieure et inférieure 0mm	
ENCHIMENTO FILLING REMPLISSAGE	10 mm 12mm 16mm	32 mm 35mm (vidros temperados) (tempered glasses verres trempés)
CORTES CUTS COUPES	45° 90°	
VEDAÇÃO INSULATION ÉTANCHÉITÉ	Juntas em EPDM EPDM joints Joint en EPDM	
PESO MÁXIMO MAXIMUM WEIGHT POIDS MAXIMALE	500 Kg/folha sash vantail Para pesos superiores, consultar o Departamento Técnico For other weights, please consult our Technical Department Pour d'autres poids, veuillez consulter notre Département Technique	
ÁREA MÁXIMA MAXIMUM AREA AIRE MAXIMALE	8,00 m ² /folha sash vantail	
ALTURA MÁXIMA MAXIMUM HEIGHT HAUTEUR MAXIMALE	4,00m/folha móvel mobile sash vantail	
ACABAMENTOS FINISHES FINITIONS	Lacados Anodizados Bicolores Powder coated Anodised Bicolour Laqué Anodisé Bicouleur	

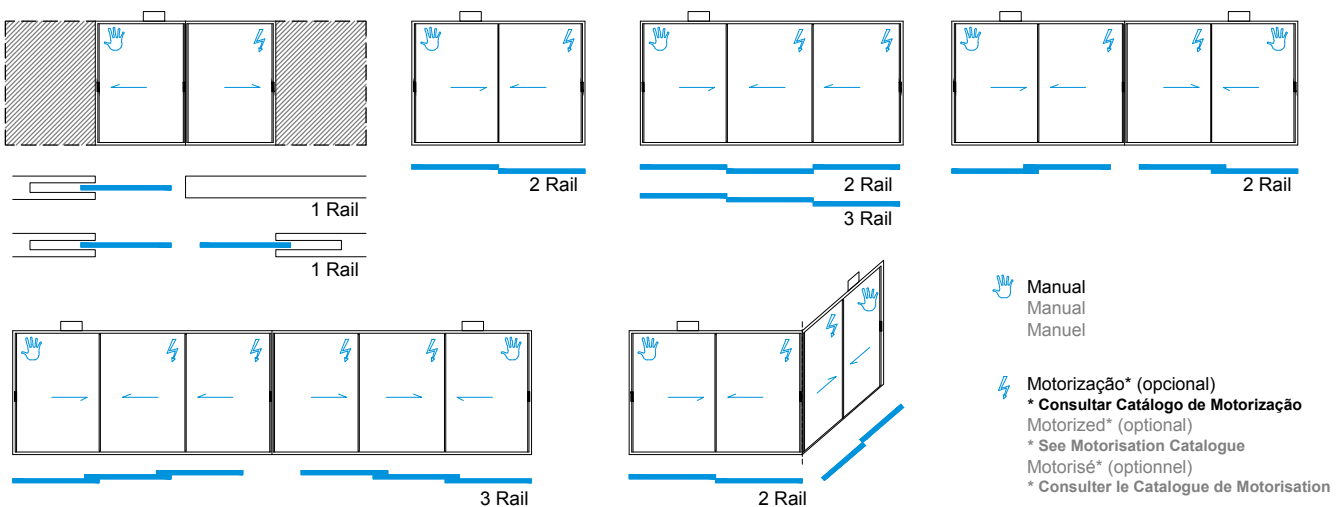

Para outras tipologias, consultar o Departamento Técnico
For other typologies, please consult our Technical Department | Pour d'autres typologies, veuillez consulter notre Département Technique

Todas as medidas são consideradas em mm, salvo as devidamente identificadas

All measurements are considered in mm, except those duly identified | Toutes les mesures sont considérées en mm saufs celles qui sont dûment identifiées

DESEMPENHO DO SISTEMA

system performance | performance du système

Marcação CE CE Marking Marquage CE	Janela de 2 folhas de correr com 3,195m x 2,595m Vidro: 8 + 16 + 8 (temperados) 2 leaves window 3,195m x 2,595m - Glass: 8 + 16 + 8 (tempered) Fenêtre 2 vantaux 3,195m x 2,595m - Verre: 8 + 16 + 8 (trempé)
Ensaio Test Essais CXL 123/19 - 17-12-2019	
Permeabilidade ao AR AIR Permeability Permeabilité à l'AIR	4
Estanquidade à ÁGUA WATER Tightness Étanchéité à l'EAU	7A
Resistência ao VENTO WIND Resistance Résistance au VENT	B3
Coef. Transm. TÉRMICA* THERMAL Transmittance Coef. Transm. THERMIQUE	Uw = 1,48 W/m²K * Ug = 1,0 W/m²K (Janela de 2 folhas com 4.10x2.70m - LxH) (2 leaves window fenêtre 2 vantaux)
Isolamento ACÚSTICO ACOUSTIC Insulation Isolation ACOUSTIQUE	Rw = 39 (-1;-3)dB - Ensaio Test Essais nº 166-19 ITeCons Janela de 2 folhas com 1,21mm x 1,46mm - LxH - OS Soleira Oculta Vidro 8 (temperado) + 14 + 55.2 (acústico) 2 leaves window with 1,21mm x 1,46mm - WxH - OS Concealed Sill Glass 8 (tempered) + 14 + 55.2 (acoustic) Fenêtre 2 vantaux avec 1,21mm x 1,46mm - LxH - OS Seuil Caché Verre 8 (trempé) + 14 + 55.2 (acoustique) Rw = 38 (-1;-4)dB - Ensaio Test Essais nº 193-19 ITeCons Janela de 2 folhas com 3,14mm x 3,14mm - LxH - OS Soleira Oculta Vidro 8 (temperado) + 14 + 55.2 (acústico) 2 leaves window with 3,14mm x 3,14mm - WxH - OS Concealed Sill Glass 8 (tempered) + 14 + 55.2 (acoustic) Fenêtre 2 vantaux avec 3,14mm x 3,14mm - LxH - OS Seuil Caché Verre 8 (trempé) + 14 + 55.2 (acoustique)

* Cálculo realizado para novos perfis OS considerando uma tipologia com soleira tradicional
Calculation performed for new OS profiles considering a typology with traditional sill
Calcul effectué pour les nouveaux profilés OS en tenant compte d'une typologie de seuil traditionnelle

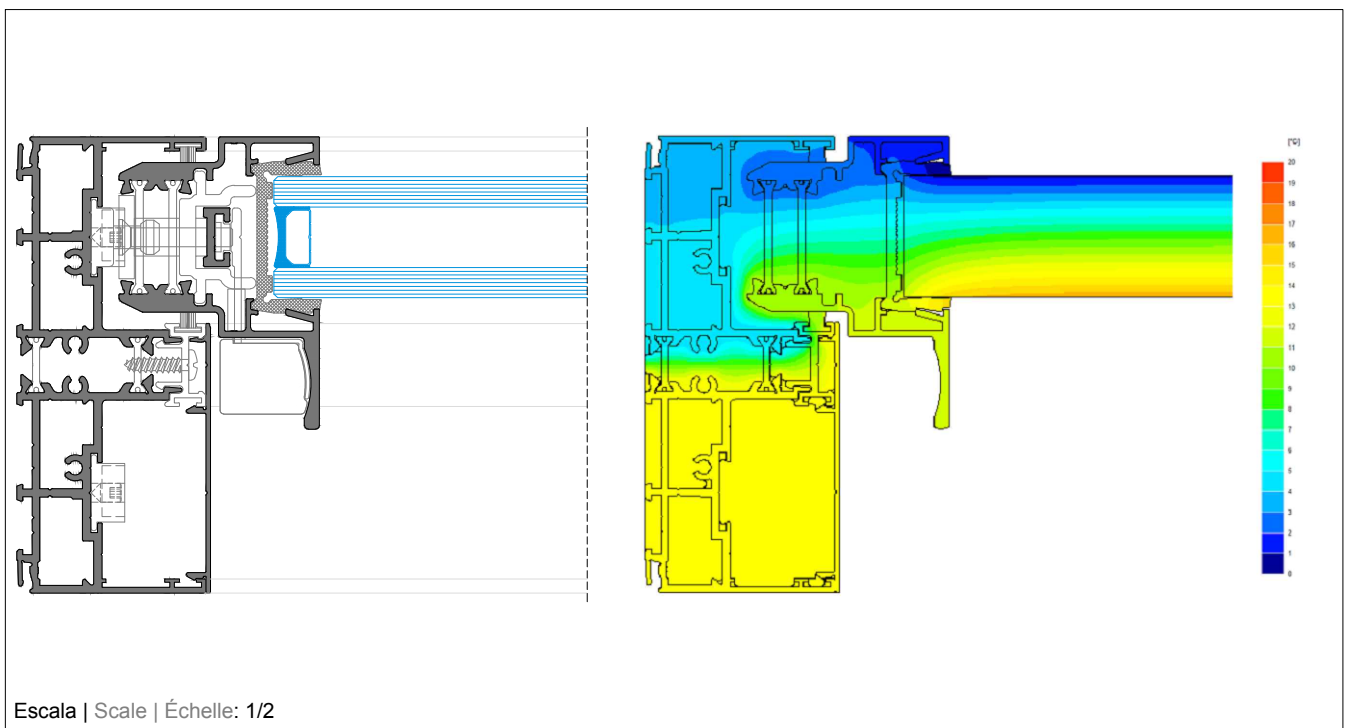

CUIDADOS A TER NA FABRICAÇÃO, MONTAGEM E MANUTENÇÃO PARA CAIXILHOS DO SISTEMA OS
CARES IN THE MANUFACTURE, INSTALLATION AND MAINTENANCE OF THE OS SYSTEM FRAMES
PRÉCAUTIONS POUR LA FABRICATION, L'ASSEMBLAGE ET LA MAINTENANCE DES CADRES DU SYSTÈME OS

1. NA FABRICAÇÃO (CORRETA EXECUÇÃO DOS CAIXILHOS)
MANUFACTURING (CORRECT FRAMES EXECUTION) | DANS LA FABRICATION (EXECUTION CORRECTE DES CHÂSSIS)

Todos os caixilhos deverão ser executados mediante os nossos catálogos técnicos e as nossas instruções técnicas. Sempre que se considerarem insuficientes os dados fornecidos, o Departamento Técnico deverá ser consultado ou solicitada a presença de um Técnico do GRUPO SOSOARES.

All frames must be executed according to our technical catalogs and technical instructions. Whenever deemed insufficient data provided, the Technical Department should be consulted or the presence of a Technician from Grupo Sosoares requested.

Tous les châssis doivent être effectués SELON nos catalogues techniques et nos instructions techniques. Lorsque considèrent insuffisantes les données fournies sont considérés insuffisantes, le Département Technique devra être consulté la présence d'un Technique du Groupe Sosoares requise.

IMPORTANTE | IMPORTANT | IMPORTANT:

- Ao realizar este sistema pela primeira vez, deverá requisitar **obrigatoriamente a presença de um técnico do GRUPO SOSOARES para auxiliar tecnicamente em todas as fases de execução (corte, maquinação, montagem e aplicação em obra), de pelo menos 1 caixilho:**
 - Ter em atenção a correta execução das drenagens de água;
 - Ter em atenção a aplicação das pelúcias corretas;
 - Ter em atenção a aplicação dos corta-vento nos aros fixos;
 - Maquinar os perfis móveis de acordo com os planos do cortante OS;
 - Executar uma correta aplicação de todos os acessórios.
- When performing this system for the first time, you should request a **mandatory presence of a technician from Grupo Sosoares to technically assist you at all stages of the implementation (cutting, milling, assembling and application on site), of at least 1 frame;**
 - Beware of the correct execution of water drainage;
 - Beware of the application of the correct brush gasket;
 - Beware of the application of the "Central-gasket" on fixed frames;
 - Milling the mobile profiles according to the OS Cutter Machine plans;
 - Execute a correct application of all accessories.
- Pour le première execution du système, veuillez la présence **obligatoire d'un Technicien du Groupe Sosoares afin de vous assister techniquement pendant toutes les phases d'exécution (coupe, usinage, assemblage et application sur site), au moins d'un châssis;**
 - Attention à la mise en œuvre correcte des drainages d'eau;
 - Attention à l'application des joint brosses correctes;
 - Attention à l'application des pièces d'étanchéité dans les dormants;
 - Usinage des profilés mobiles selon les plans d'outillage OS;
 - Application correcte de tous les accessoires.

2. NA MONTAGEM (RIGOR NAS PLANIMETRIAS DOS VÃOS)
IN ASSEMBLY (RIGOUR ON FRAMES' PLANIMETRY) | DANS L'ASSEMBLAGE (RIGEUR DANS LAS PLANIMÉTRIES DES BAIES)

Para um excelente funcionamento, é extremamente importante o executante/instalador deste sistema sensibilizar e responsabilizar o projetista e consequentemente o construtor para um elevado rigor nas planimetrias e nivelamentos da alvenaria para os vãos a que este sistema esteja destinado. Devem conferir estas mesmas características (planimetria e nivelamento) antes de aplicar os aros fixos e só após se confirmarem as devidas condições, fazer a aplicação em obra com idêntico rigor.

In order to achieve an excellent functioning, it is extremely important that the performer/installer of this system should warn and consequently blame the constructor regarding a high accuracy in planimetry and leveling the masonry for the frames that this system is designed for. They should check these same characteristics (planimetry and leveling) before applying the fixed frames and only after the proper conditions are confirmed, apply on site with the same rigour.

Afin d'obtenir les meilleures performances, il est extrêmement important l'exécutant/installateur de ce système sensibilise et responsabilise le concepteur et par conséquent le constructeur par rapport à une grande précision dans les planimétries et le nivellement de la maçonnerie pour les baies dont ce système est destiné. Veuillez vérifier ces mêmes caractéristiques (planimétrie et de nivellement) avant d'appliquer les cadres fixes et seulement après avoir confirmé que les conditions sont appropriées, faire l'application sur site avec la même rigueur.

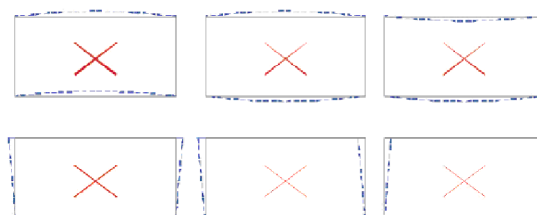
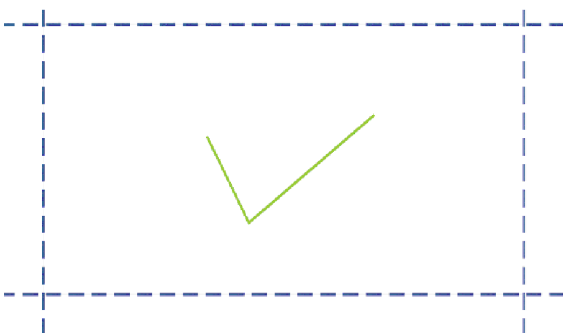

CUIDADOS A TER NA FABRICAÇÃO, MONTAGEM E MANUTENÇÃO PARA CAIXILHOS DO SISTEMA OS
CARES IN THE MANUFACTURE, INSTALLATION AND MAINTENANCE OF THE OS SYSTEM FRAMES
PRÉCAUTIONS POUR LA FABRICATION, L'ASSEMBLAGE ET LA MAINTENANCE DES CADRES DU SYSTÈME OS

3. APÓS MONTAGEM (CUIDADOS DE MANUTENÇÃO)
AFTER ASSEMBLY (MAINTENANCE CARES) | APRÈS L'ASSEMBLAGE (PRÉCAUTIONS DE MAINTENANCE)

ALUMÍNIO LACADO E ANODIZADO
POWDER COATED AND ANODISED ALUMINIUM | ALUMINIUM LAQUÉ ET ANODISÉ

O alumínio depois de instalado em obra, requer uma limpeza regular para assim manter a sua superfície em bom estado. Quaisquer que sejam as peças de alumínio, perfis ou acessórios, se não forem devidamente tratadas podem sofrer danos que, em determinadas situações podem ser irreparáveis.

The aluminum, once installed on site, requires a regular cleaning in order to maintain its surface in good condition. Pieces of aluminum including profiles and accessories, if not properly treated, can be damage that, which in certain situations could be irreparable.

L'aluminium, une fois installé sur site, nécessite d'un nettoyage régulier afin de maintenir sa surface en bon état. Quelles que soient les pièces en aluminium, profilés ou accessoires, par manque de traitement adéquat peuvent être endommagés et dans certaines situations, ces dommages peuvent être irréparables.

CONTATO COM OUTROS MATERIAIS
CONTACT WITH OTHER MATERIALS | CONTACT AVEC D'AUTRES MATÉRIAUX

Sempre que o material for atingido por colas, mástiques ou produtos similares, cimento, cal, tintas ou quaisquer outros elementos utilizados na construção civil, deve-se proceder de imediato à respetiva remoção, recorrendo a um detergente líquido de PH neutro, diluído em água.

Whenever the material is hit by glues, mastics or similar products, cement, lime, paint or any other elements used in construction, you must immediately proceed to the due removal, using a PH neutral liquid detergent diluted in water.

Lorsque le matériel est souillé par des colles, mastics ou produits similaires, le ciment, la chaux, peinture ou d'autres éléments utilisés dans le bâtiment, il faut immédiatement procéder au respectif retrait, en utilisant un détergent liquide de pH neutre dilué avec de l'eau.

LIMPEZA DAS ZONAS DE DESLIZAMENTO
SLIDING AREAS CLEANSING | NETTOYAGE DES ZONES DE COULISSAGE

As zonas por onde deslizam os carrinhos deverão estar sempre limpas e desimpedidas de quaisquer objetos ou materiais (p.ex. areias, pedras, serrins, pós, terras, etc. ...) que possam diminuir as capacidades dos carrinhos, ou mesmo danificá-los. Estas impurezas poderão gerar danos irreparáveis e conseqüentemente um pior funcionamento do sistema. Tal limpeza deverá ser efectuada tantas vezes quanto as necessárias.

The areas where the sliding wheels carts slide should be kept clean and unobstructed of any objects or materials (sand, stones, dust, e.g.) that can reduce the capacity of the roller bearings, or even damage them. These impurities may produce permanent damaged and consequently a worse functioning of the system. Such cleansing must be carried out as many times as necessary.

Les zones où les rouleaux coulissent doivent être propres et dégagées de tout objet ou du matériaux (p.ex: sable, pierres, sciure, poudres, terres, etc ...) qui peuvent réduire la capacité des rouleaux, ou même les endommager. Ces impuretés peuvent produire des dommages irréversibles et donc un moins bon fonctionnement du système. Un tel nettoyage doit être effectué autant de fois que nécessaire.

PRODUTOS DE LIMPEZA A UTILIZAR
CLEANING PRODUCTS TO BE USED | PRODUITS DE NETTOYAGE À UTILISER

De um modo geral, um pano macio embebido em água é suficiente para limpar o alumínio. No entanto, para facilitar a operação, pode-se adicionar um detergente neutro líquido e macio, diluído (5% em volume) do tipo "Teepol".

In general, a cloth moistened with water is sufficient to clean aluminum. However, to facilitate the operation you can add a liquid detergent, soft dilute (5% by volume), like "Teepol".

En général, un chiffon doux imbibé d'eau est suffisant pour nettoyer l'aluminium. Toutefois, pour faciliter l'opération, on peut ajouter un détergent neutre liquide et doux dilué (5% en volume) type "Teepol".

PRODUTOS DE LIMPEZA A EVITAR
CLEANING PRODUCTS TO AVOID | PRODUITS DE NETTOYAGE À ÉVITER

Nunca utilizar escovas, lixas, esfregões, ou qualquer outro tipo de material abrasivo, bem como produtos de limpeza à base de solventes (ex. diluente, limpa vidros à base de amónia, etc.).

Never use brushes, scrapers, mops, or any other kind of abrasive material as well as cleaning products based on solvents (eg diluent wiper based on ammonia, etc.).

Ne jamais utiliser des brosses, du papier de verre, vadrouille, ou de tout autre matériau abrasif ainsi que des produits de nettoyage à base de solvants (ex. diluant, essuie-glace à base d'ammoniac, etc.).

CUIDADOS A TER NA FABRICAÇÃO, MONTAGEM E MANUTENÇÃO PARA CAIXILHOS DO SISTEMA OS
CARES IN THE MANUFACTURE, INSTALLATION AND MAINTENANCE OF THE OS SYSTEM FRAMES
PRÉCAUTIONS POUR LA FABRICATION, L'ASSEMBLAGE ET LA MAINTENANCE DES CADRES DU SYSTÈME OS

PRODUTOS DE LIMPEZA A EVITAR

CLEANING PRODUCTS TO AVOID | PRODUITS DE NETTOYAGE À ÉVITER

Nunca utilizar escovas, lixas, esfregões, ou qualquer outro tipo de material abrasivo, bem como produtos de limpeza à base de solventes (ex. diluente, limpa vidros à base de amónia, etc.).

Never use brushes, scrapers, mops, or any other kind of abrasive material as well as cleaning products based on solvents (eg diluent wiper based on ammonia, etc.).

Ne jamais utiliser des brosses, du papier de verre, vadrouille, ou de tout autre matériau abrasif ainsi que des produits de nettoyage à base de solvants (ex. diluant, essuie-glace à base d'ammoniac, etc.).

FREQUÊNCIA DA LIMPEZA

CLEANING FREQUENCY | FRÉQUENCE DE NETTOYAGE

A limpeza deve ser levada a cabo sempre que a aparência natural do acabamento começar a alterar ou quando forem notórios depósitos de poluição atmosférica ou industrial. Pode no entanto, ser estabelecida a seguinte regra, respeitante à frequência da limpeza:

- Zonas marítimas e/ou industriais: 3 meses;
- Zonas rurais: 6 meses;
- Zonas onde ocorram fortes deposições de sal: deve ser identificada a frequência de limpeza de modo a não permitir a permanência prolongada dos sais.

Cleaning should be carried out whenever the natural appearance of the aluminium treatment starts to change or when industrial and air pollution deposits become notorious. We may however establish the following rule concerning the frequency of cleaning:

- Industrial and/or seaside: 3 months;
- Countryside: 6 months;
- Areas where a heavy deposition of salt happens: please adapt the cleaning frequency in order to prevent the prolonged permanence of salts.

Le nettoyage doit être effectué lorsque l'aspect naturel de la finition commence à changer ou lorsque les dépôts de la pollution atmosphérique ou industrielle deviennent visible. Nous pouvons établir cependant la règle suivante concernant la fréquence de nettoyage:

- Zones maritimes et / ou industriels: 3 mois;
- Zones rurales: 6 mois;
- Les zones où se produisent d'importants dépôts de sel: veuillez adapter de façon à ce sorte que la fréquence de nettoyage ne permette pas aux sels une permanence prolongée.



Casa em Rishon LeZion | Israel | Shohar Rosenfeld, Arq. | Fotografia Shai Epstein

II

LISTAGEM DE PERFIS PROFILES LIST | LISTE DES PROFILÉS

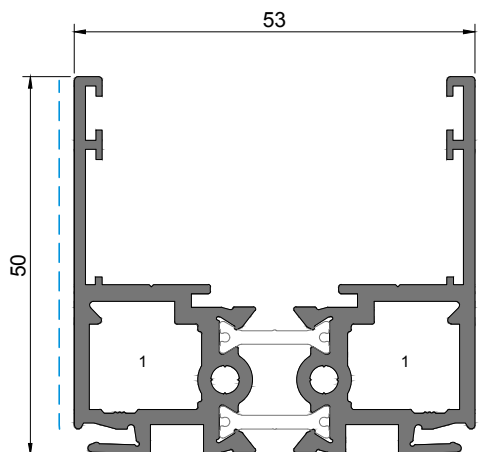

SO 14

Ombreira/padieira/soleira 1-rail
1-rail Door jamb/lintel/sill | Jambage/linteau/seuil 1-rail

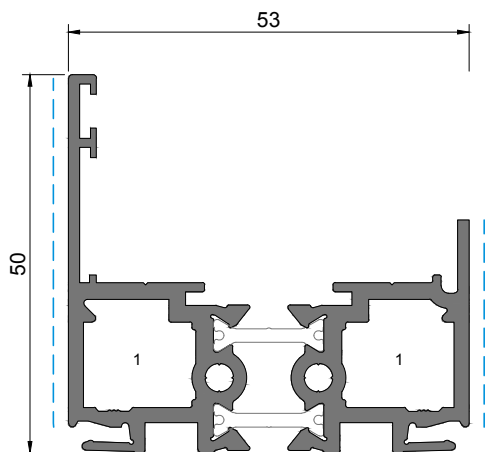

SO 15

Ombreira/soleira 1-rail
1-rail Door jamb/sill | Jambage/seuil 1-rail

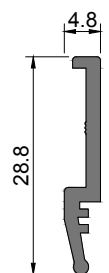

SO 16

Bite
Bead | Parclose

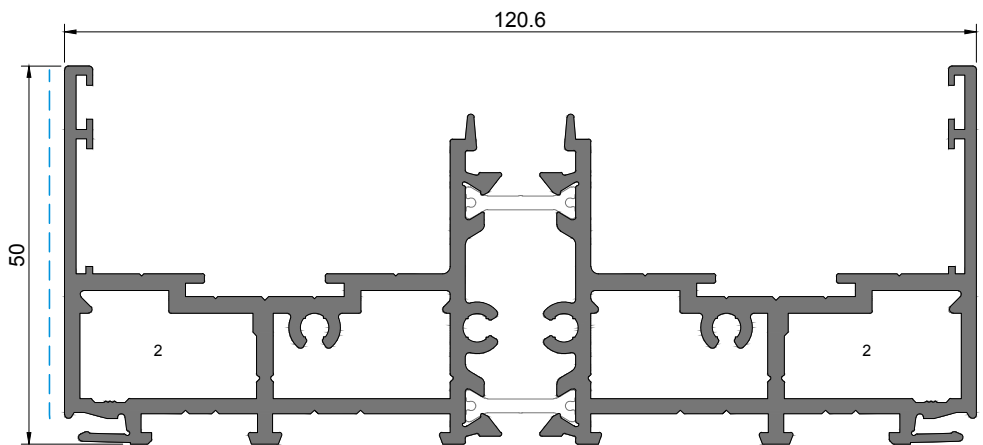

SO 11

Ombreira/padieira/soleira 2-rail
2-rail Door jamb/lintel/sill | Jambage/linteau/seuil 2-rail

1 - ESQUADRO | BRACKET | EQUËRRE 18-1310-C

2 - ESQUADRO | BRACKET | EQUËRRE 18-2210-D

3 - ESQUADRO | BRACKET | EQUËRRE 18-3112-C

Treatment de superficie | Surface treatment | Traitement de surface
PB | PM | EF | EM PB | EF | EM
Para mais informações, consultar Catálogo de Cores Anodizadas
For further information, consult the Anodised Colours Catalogue | Pour plus d'informations, veuillez consulter le Catalogue des Couleurs Anodisées

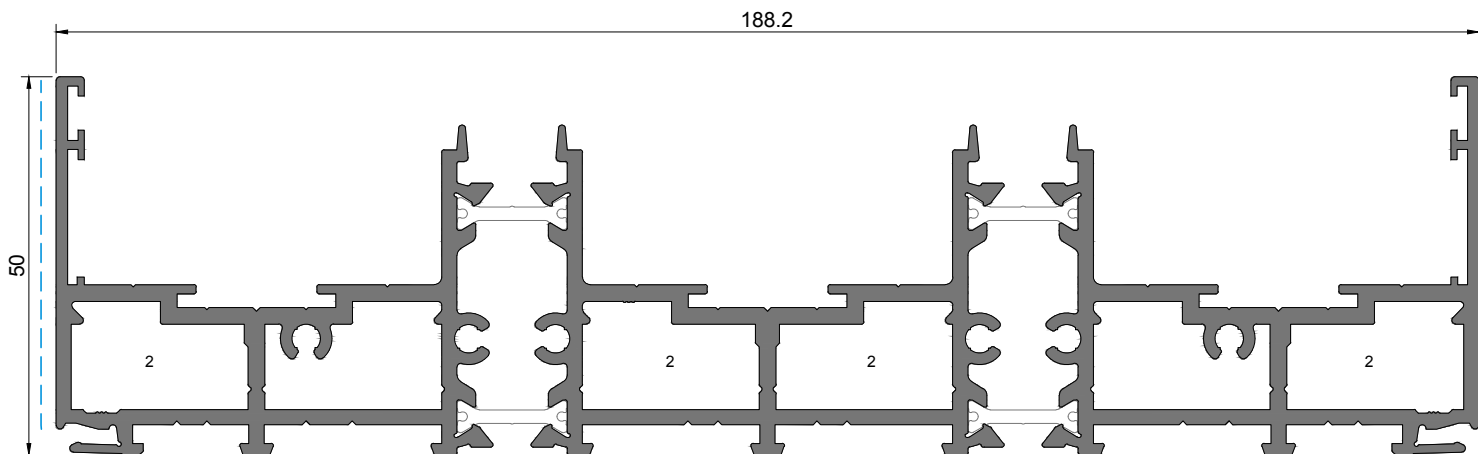

SO 12

Ombreira/padieira/soleira 3-rail
3-rail Door jamb/lintel/sill | Jambage/linteau/seuil 3-rail

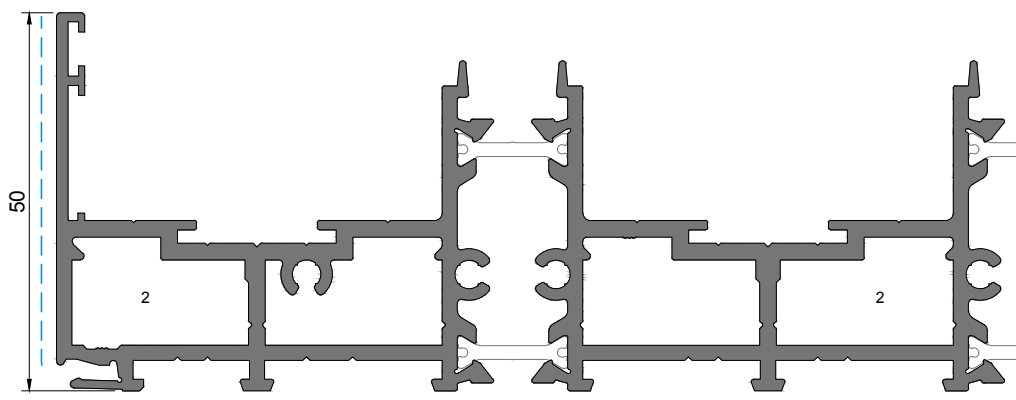

SO 13

Ombreira/padieira/soleira 4-rail
4-rail Door jamb/lintel/sill | Jambage/linteau/seuil 4-rail

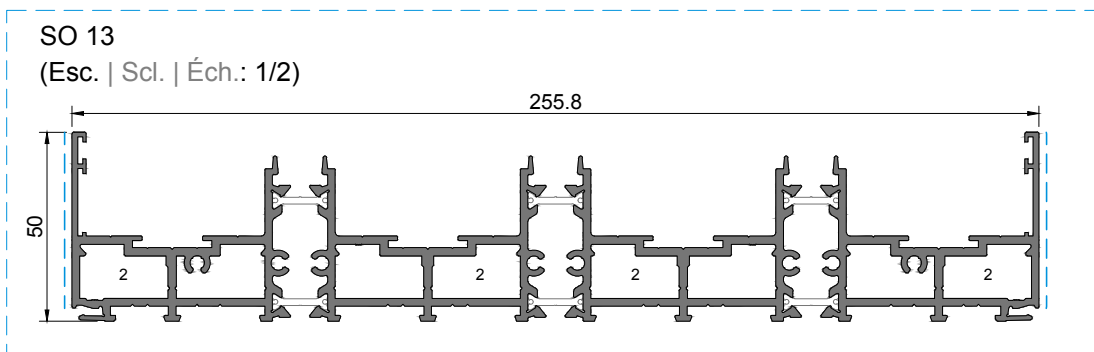

SO 13

(Esc. | ScI. | Éch.: 1/2)

255.8

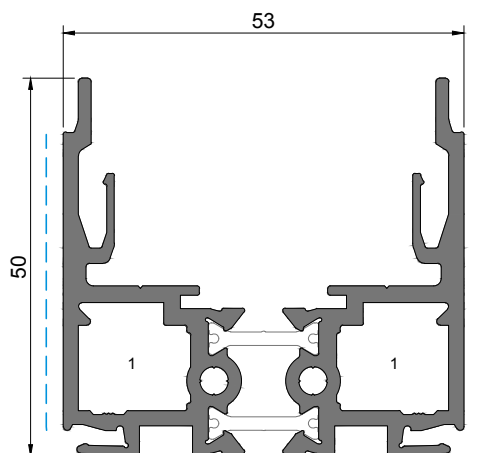

SO 24
Soleira oculta 1-rail
1-rail Concealed sill | Seuil cachée 1-rail

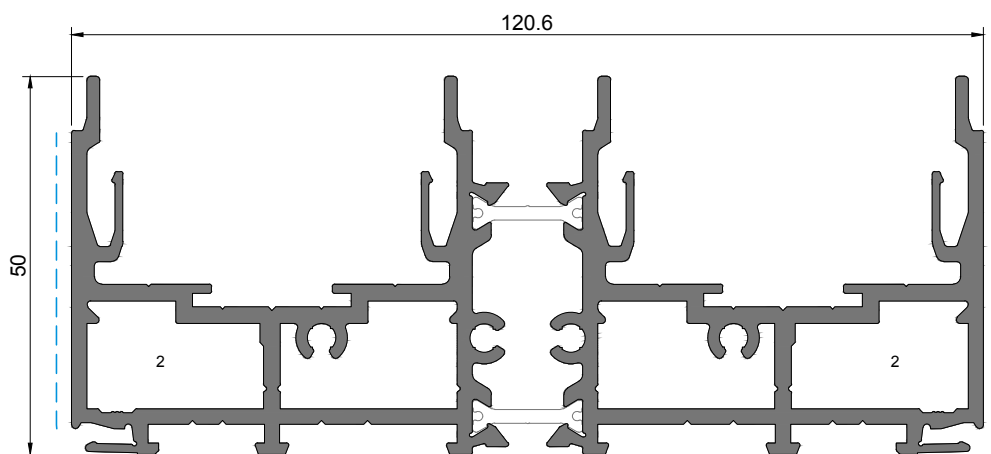

SO 21
Soleira oculta 2-rail
2-rail Concealed sill | Seuil cachée 2-rail

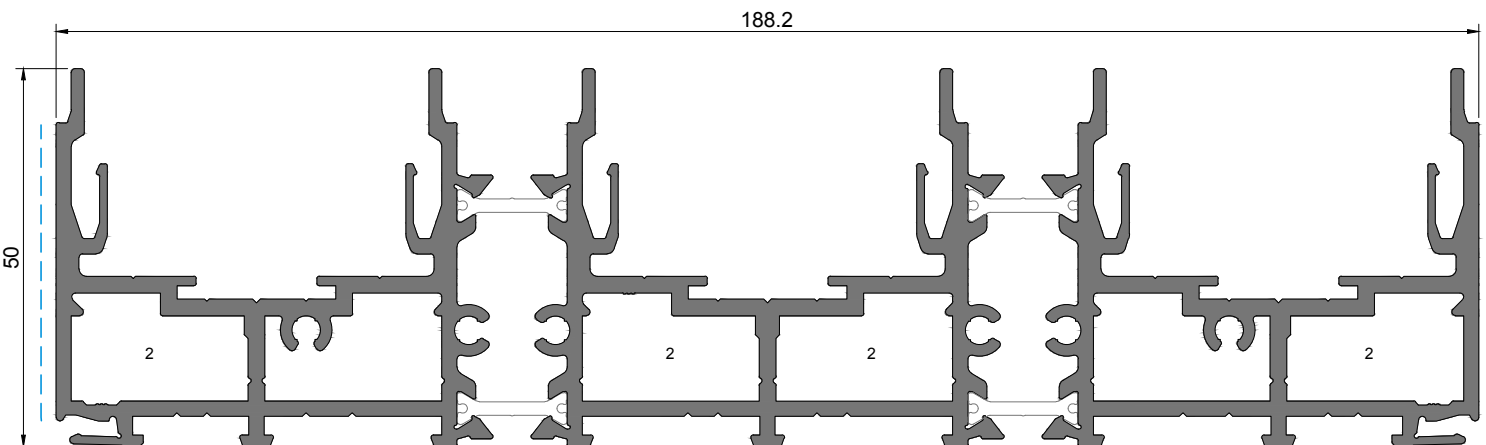

SO 22

Soleira oculta 3-rail
3-rail Concealed sill | Seuil cachée 3-rail

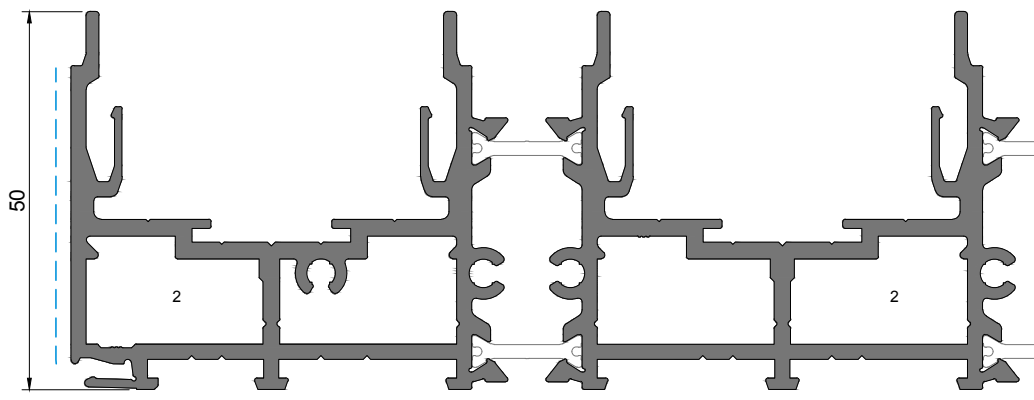

SO 23

Soleira oculta 4-rail
4-rail Concealed sill | Seuil cachée 4-rail

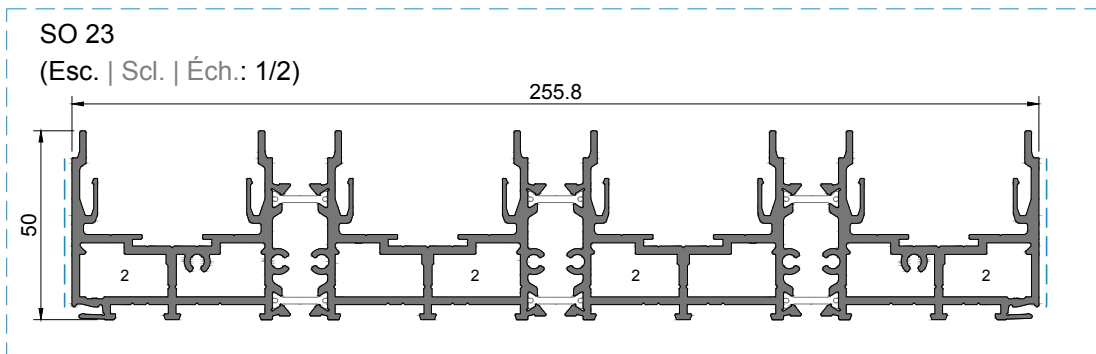

1 - ESQUADRO | BRACKET | EQUËRRE 18-1310-C

2 - ESQUADRO | BRACKET | EQUËRRE 18-2210-D

3 - ESQUADRO | BRACKET | EQUËRRE 18-3112-C

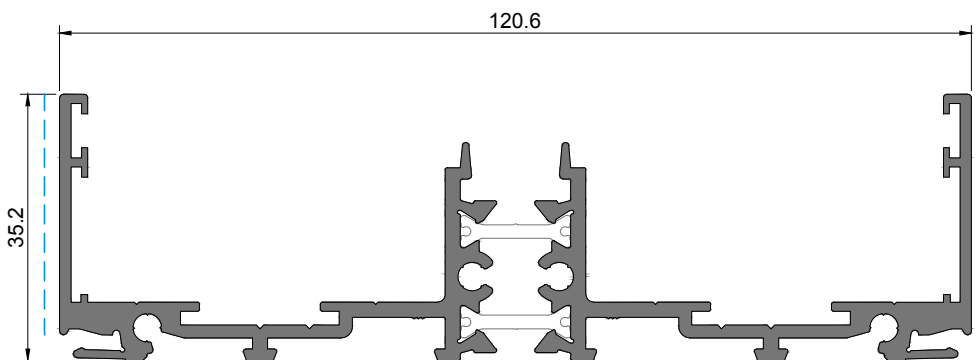

SO 05

Aro baixo para soleira 2-rail
2-rail Low frame for sill | Dormant bas pour seuil 2-rail

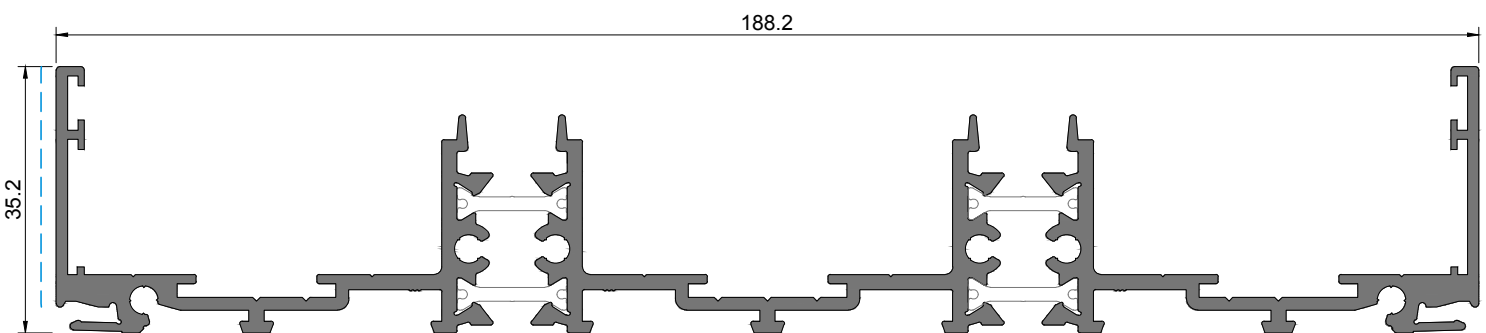

SO 06

Aro baixo para soleira 3-rail
3-rail Low frame for sill | Dormant bas pour seuil 3-rail

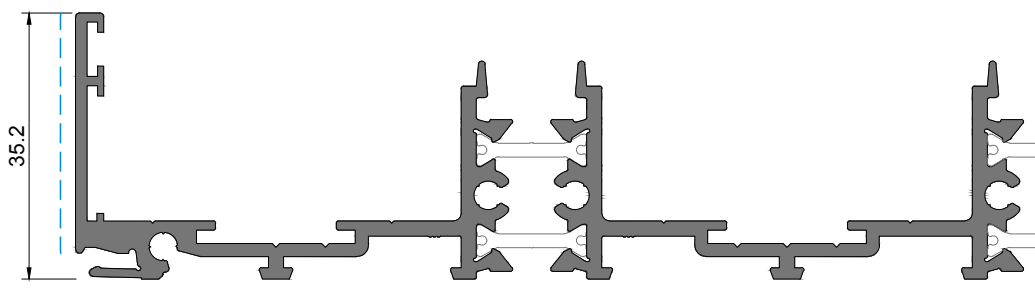

SO 07

Aro baixo para soleira 4-rail
4-rail Low frame for sill | Dormant bas pour seuil 4-rail

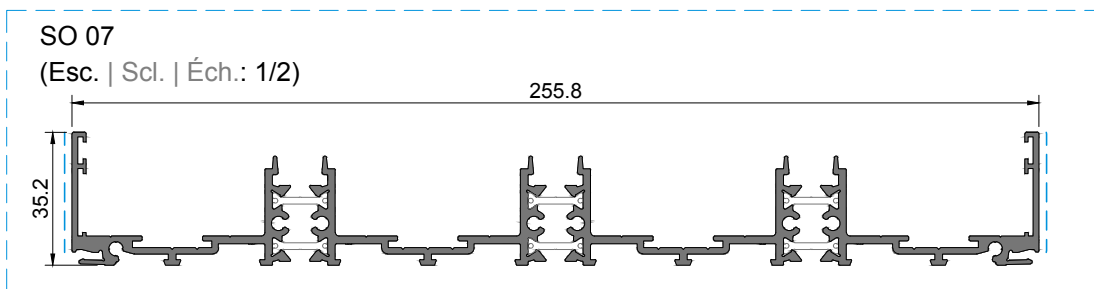

SO 07

(Esc. | ScI. | Éch.: 1/2)

255.8

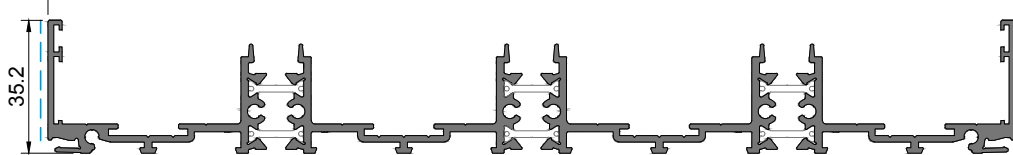

Treatmento de superficie | Surface treatment | Traitement de surface
PB | PM | EF | EM PB | EF | EM
Para mais informações, consultar Catálogo de Cores Anodizadas
For further information, consult the Anodised Colours Catalogue | Pour plus d'informations, veuillez consulter le Catalogue des Couleurs Anodisées

PERFIS NÃO DISPONÍVEIS (PERFIS COMPONENTES DO VIDRO)

NOT AVAILABLE PROFILES (GLASS COMPONENT PROFILES) | PROFILÉS PAS DISPONIBLES (PROFILÉS COMPOSANT DU VERRE)

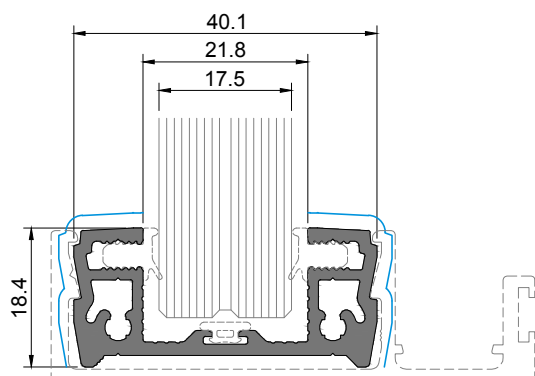

OS 87
Perfil de alumínio para vidro
Glazing aluminum profile
Profilé d'aluminium pour verre

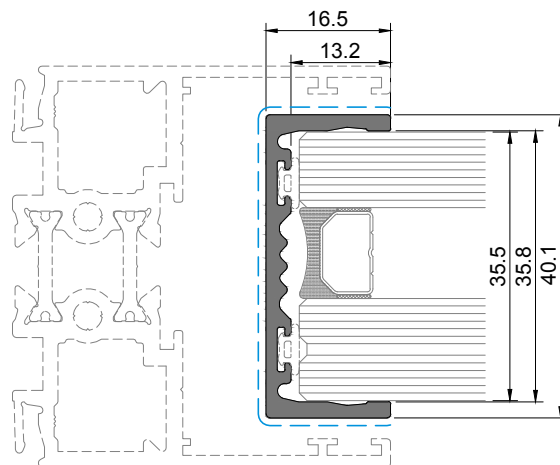

VO 96
Perfil de alumínio para vidro
Glazing aluminum profile
Profilé d'aluminium pour verre

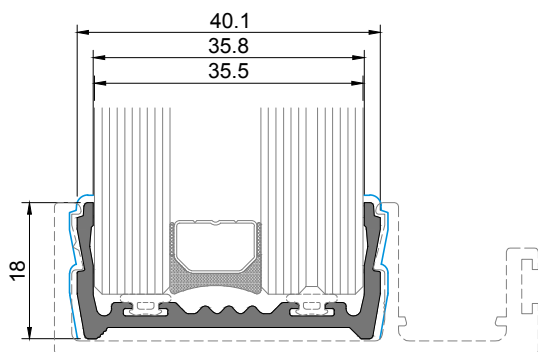

VO 97
Perfil de alumínio para vidro
Glazing aluminum profile
Profilé d'aluminium pour verre

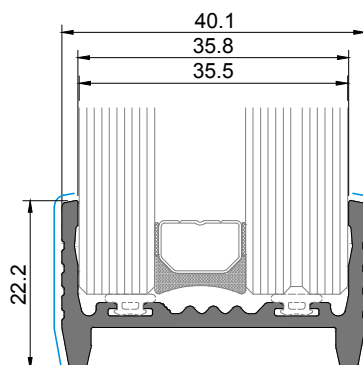

VO 98
Perfil de alumínio para vidro
Glazing aluminum profile
Profilé d'aluminium pour verre

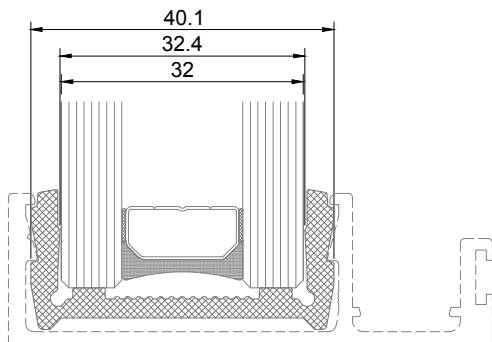

OS 96
Perfil de poliamida para vidro
Glazing polyamide profile
Profilé en polyamide pour verre

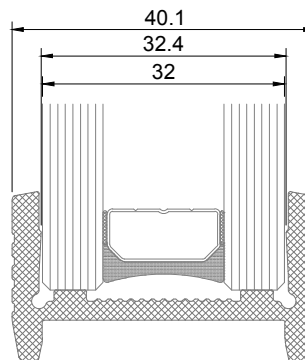

OS 96B
Perfil de poliamida para vidro
Glazing polyamide profile
Profilé en polyamide pour verre

Tratamento de superfície | Surface treatment | Traitement de surface
 PB | PM | EF | EM PB | EF | EM
 Para mais informações, consultar Catálogo de Cores Anodizadas
 For further information, consult the Anodised Colours Catalogue | Pour plus d'informations, veuillez consulter le Catalogue des Couleurs Anodisées

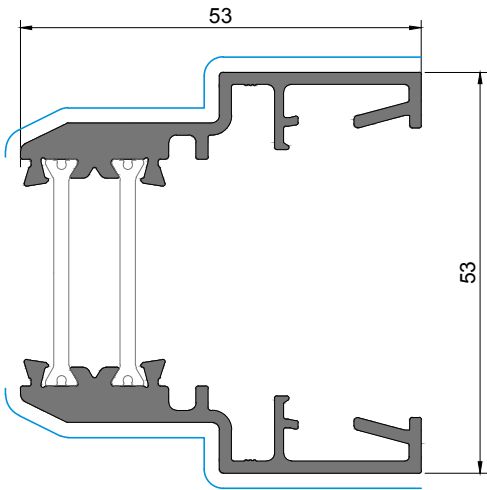

SO 64
Perfil móvel lateral
Mobile lateral profile
Cadre ouvrant latéral

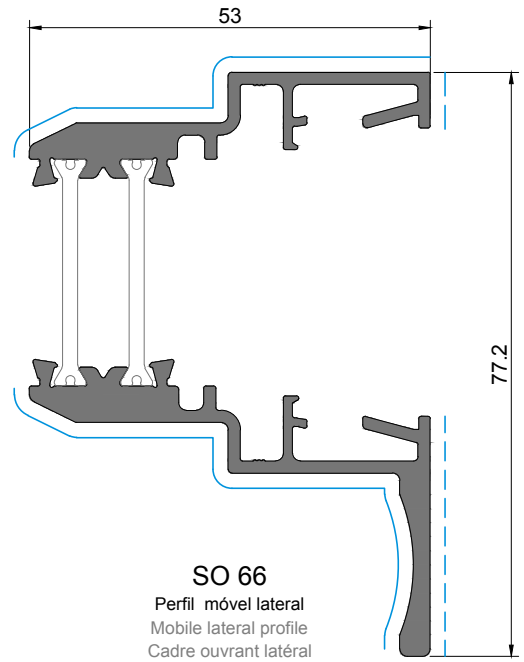

SO 66
Perfil móvel lateral
Mobile lateral profile
Cadre ouvrant latéral

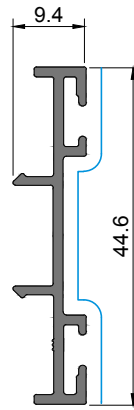

SO 40
Perfil testa fechadura
Lock plate profile
Profilé plaque pour serrure

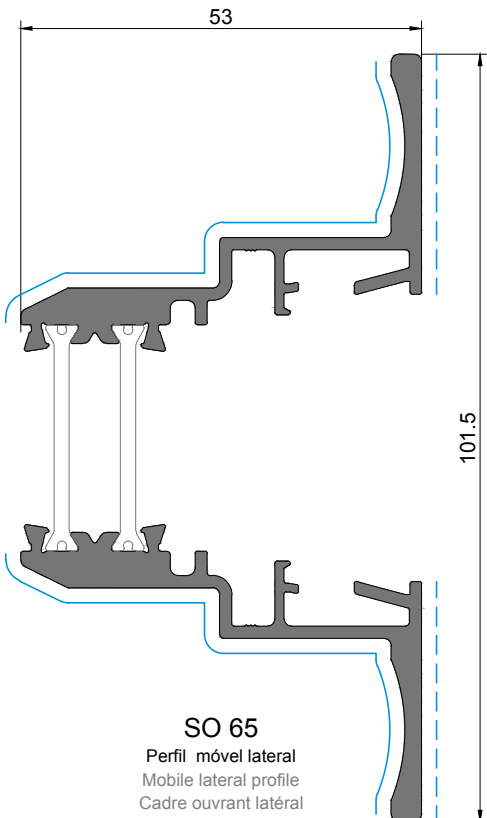

SO 65
Perfil móvel lateral
Mobile lateral profile
Cadre ouvrant latéral

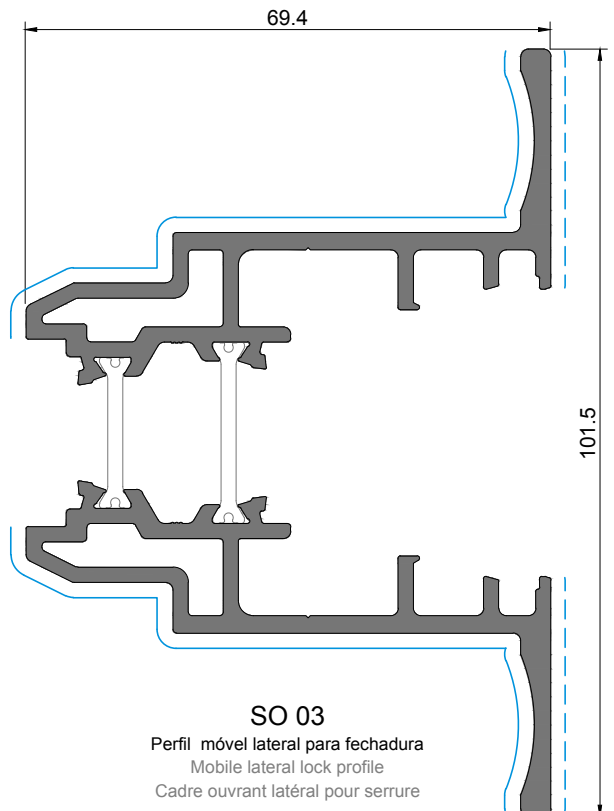

SO 03
Perfil móvel lateral para fechadura
Mobile lateral lock profile
Cadre ouvrant latéral pour serrure

Treatmento de superficie | Surface treatment | Traitement de surface
PB | PM | EF | EM PB | EF | EM
Para mais informações, consultar Catálogo de Cores Anodizadas
For further information, consult the Anodised Colours Catalogue | Pour plus d'informations, veuillez consulter le Catalogue des Couleurs Anodisées

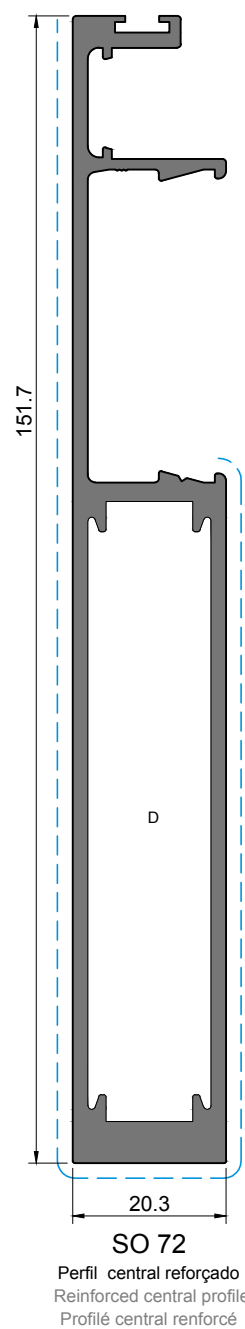
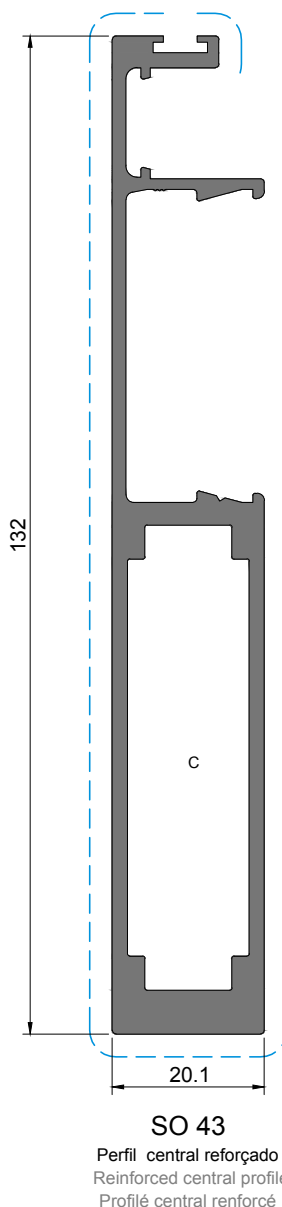
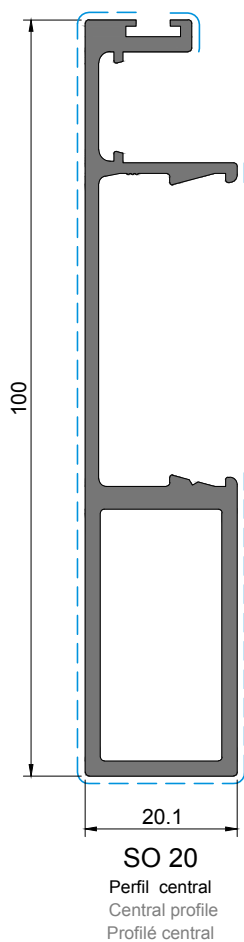
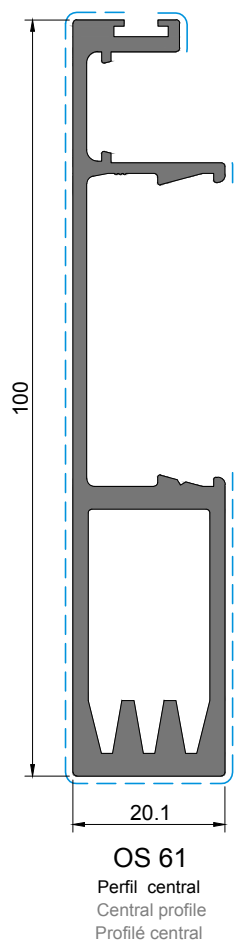
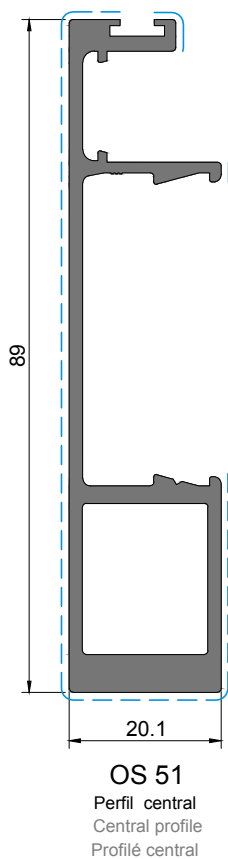
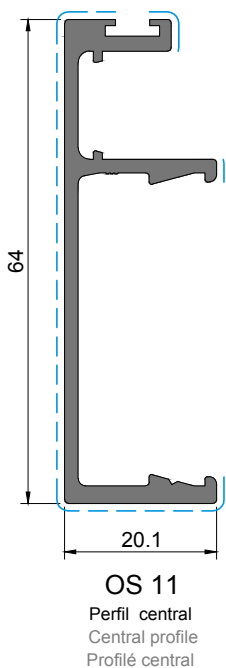

A - BARRA | BAR | BARRE 40x10mm

B - BARRA | BAR | BARRE 50x10mm

C - BARRA | BAR | BARRE 60x10mm

D - BARRA | BAR | BARRE 80x10mm

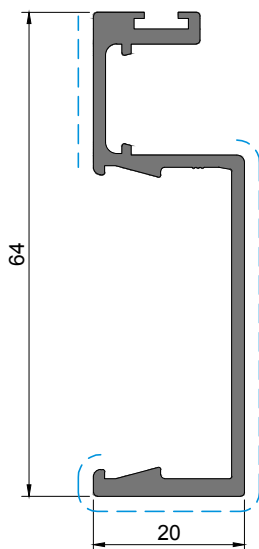

OS 17
Perfil central invertido
Inverted central profile
Profilé central inversé

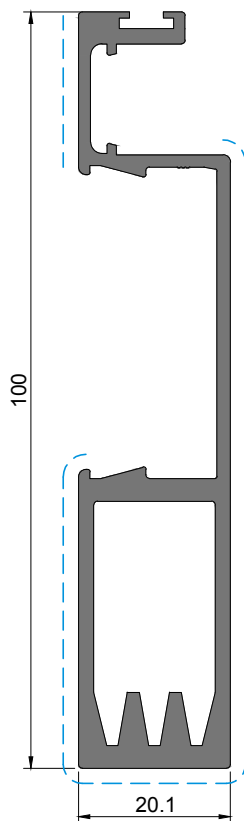

OS 67
Perfil central invertido
Inverted central profile
Profilé central inversé

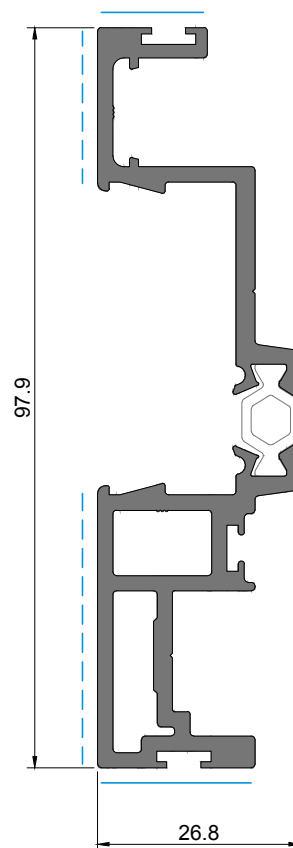

SO 38
Perfil central invertido
Inverted central profile
Profilé central inversé

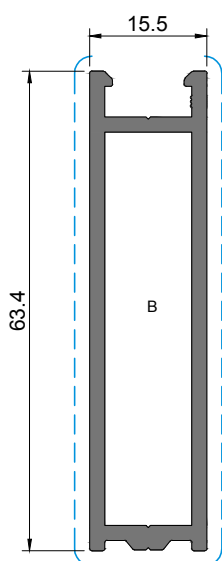

SO 67
Perfil de reforço/puxador
Reinforcement profile/handle
Profilé de reinforcement/poignée

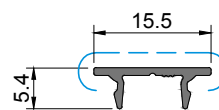

SO 57
Capa
Cover
Capot

A - BARRA | BAR | BARRE 40x10mm

B - BARRA | BAR | BARRE 50x10mm

C - BARRA | BAR | BARRE 60x10mm

D - BARRA | BAR | BARRE 80x10mm

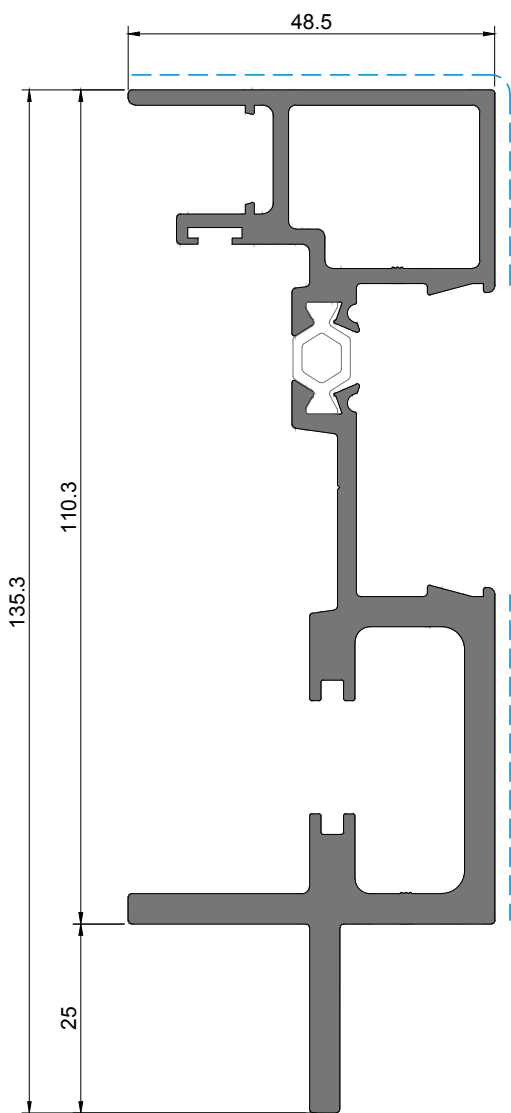

SO 39
Perfil ligação 2 folhas
2 Sashes connection profile
Profilé pour connexion 2 vantaux

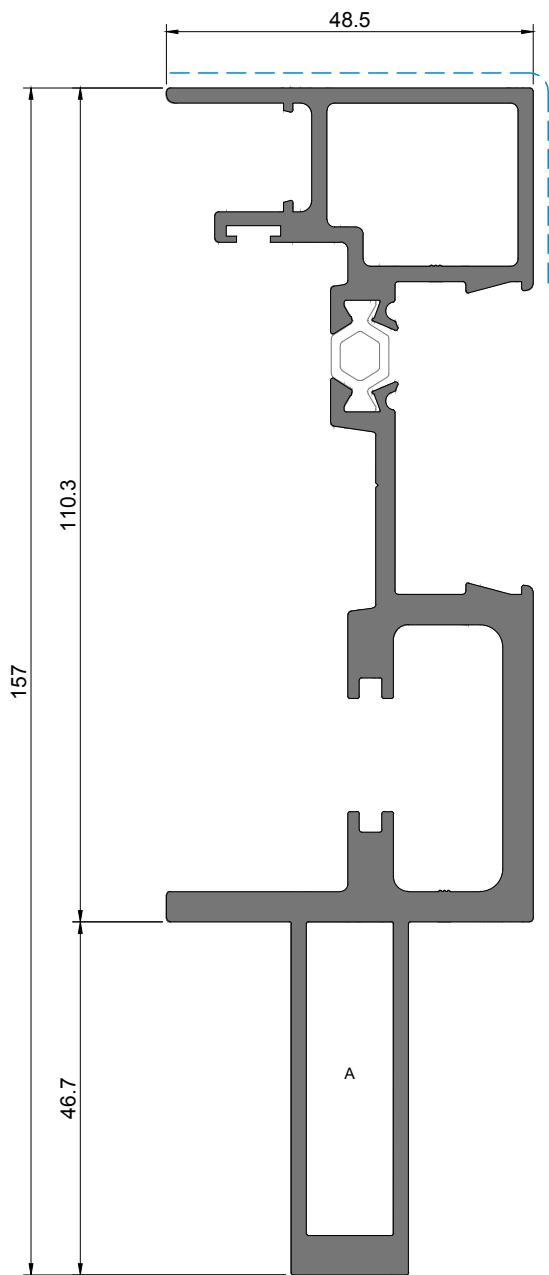

SO 53
Perfil ligação 2 folhas reforçado
2 Sashes connection reinforced profile
Profilé pour connexion 2 vantaux reforcé

A - BARRA | BAR | BARRE 40x10mm

B - BARRA | BAR | BARRE 50x10mm

C - BARRA | BAR | BARRE 60x10mm

D - BARRA | BAR | BARRE 80x10mm

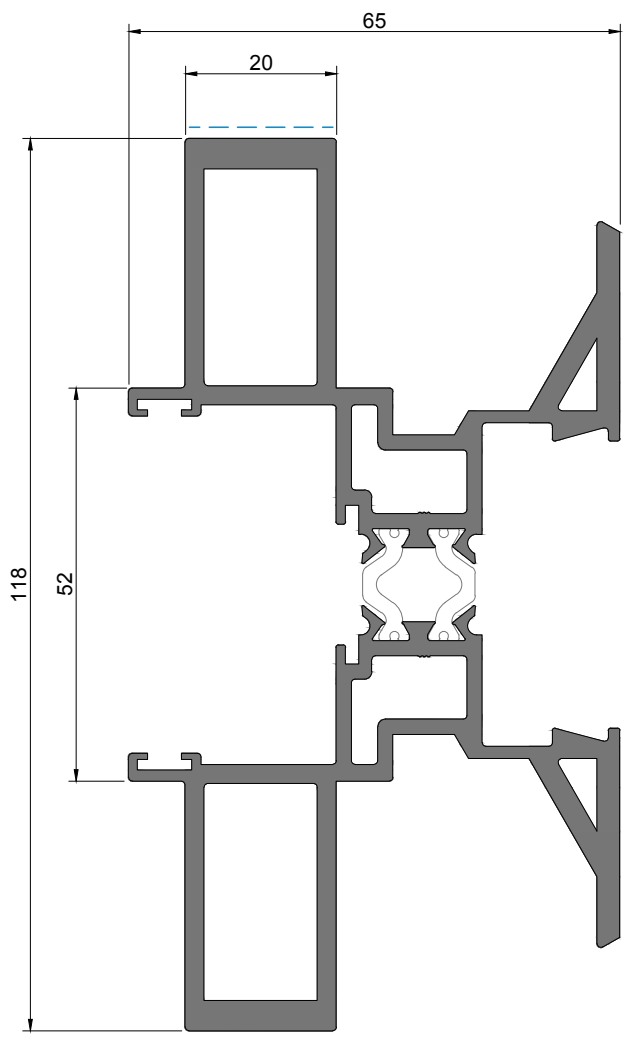

OS 27
Perfil união 3/4 folhas
3/4 Sashes connecting profile
Profilé pour connexion 3/4 vantaux

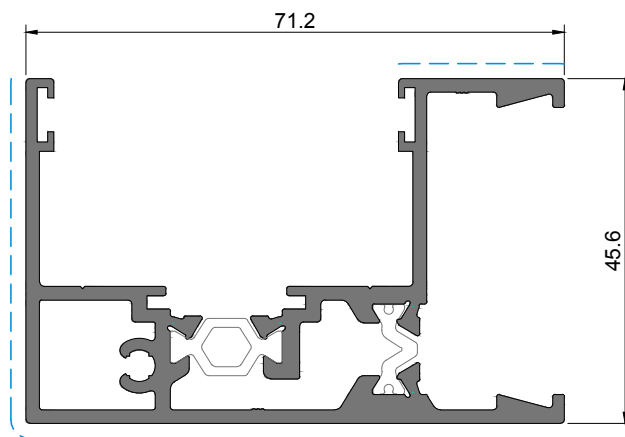

SO 10
Perfil canto reduzido 90°
90° Reduced corner profile | Profilé de angle réduit 90°

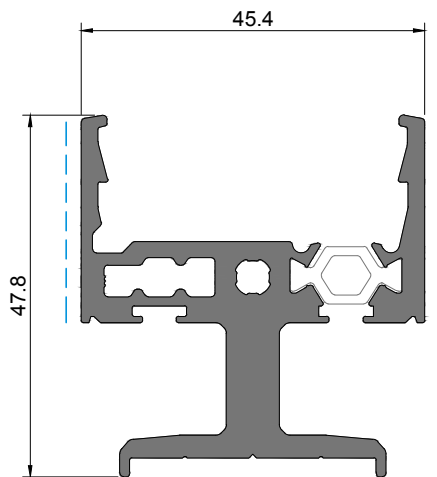

OS 08
Perfil móvel para soleira oculta
Concealed sill mobile profile
Profilé mobile pour seuil caché

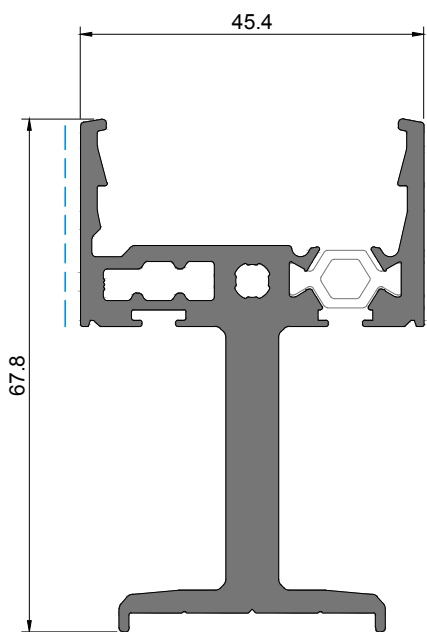

OS 18
Perfil móvel para soleira oculta
Concealed sill mobile profile
Profilé mobile pour seuil caché

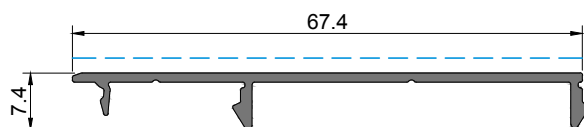

SO 63
Capa
Cover | Capot

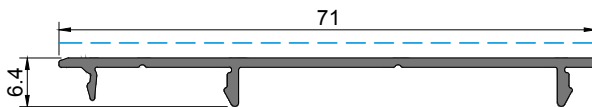

SO 60
Capa
Cover | Capot

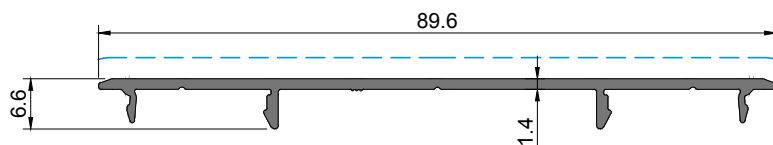

SO 62
Capa
Cover | Capot

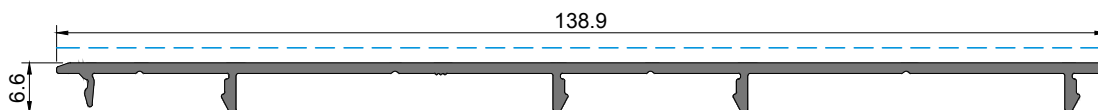

SO 61
Capa
Cover | Capot

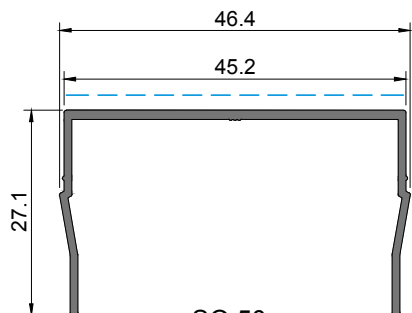

SO 50
Capa
Cover | Capot

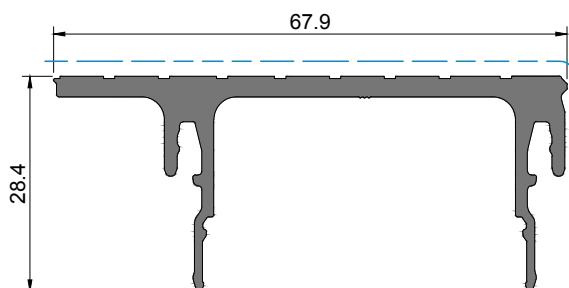

SO 71
Capa para soleira oculta
Concealed sill cover | Capot pour seuil cacé

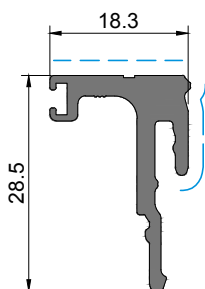

OS 40
Capa para soleira oculta
Concealed sill cover | Capot pour seuil cacé

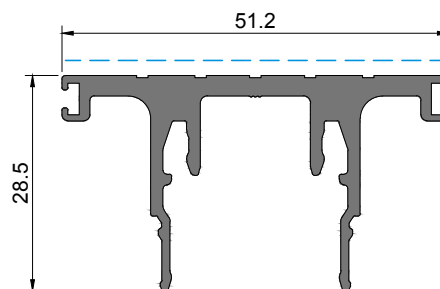

OS 41
Capa para soleira oculta
Concealed sill cover | Capot pour seuil cacé

Tratamento de superfície | Surface treatment | Traitement de surface
 PB | PM | EF | EM PB | EF | EM
 Para mais informações, consultar Catálogo de Cores Anodizadas
 For further information, consult the Anodised Colours Catalogue | Pour plus d'informations, veuillez consulter le Catalogue des Couleurs Anodisées



OS 801
Guia aço inox
Stainless steel guide | Guide acier inox

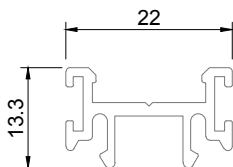

OS 95
Poliamida
Polyamide | Polyamide

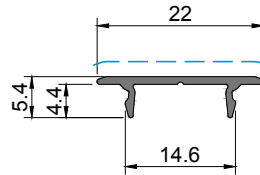

OS 30
Capa
Cover | Capot

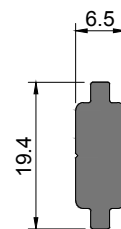

SO 33
Perfil vareta duplo
Perfil exclusivamente anodizado
Double rod profile
Profile exclusively anodised
Tige double
Profilé exclusivement anodisé

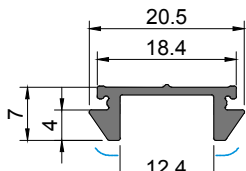

OS 35
Perfil guia superior
Perfil exclusivamente anodizado
Upper guide profile
Profile exclusively anodised
Profilé guide supérieur
Profilé exclusivement anodisé

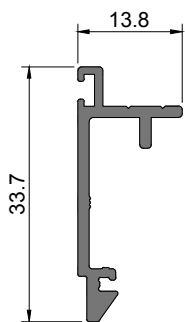

SO 37
Guia para motorização
Perfil exclusivamente anodizado
Motorization guide
Profile exclusively anodised
Guide pour motorisation
Profilé exclusivement anodisé

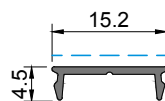

AT 30
Capa
Cover | Capot

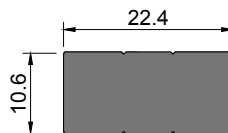

VO 21
Perfil de ligação
Connection profile | Profilé de liaison

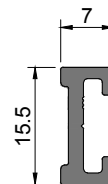

SO 30
Perfil vareta
Rod profile
Tige

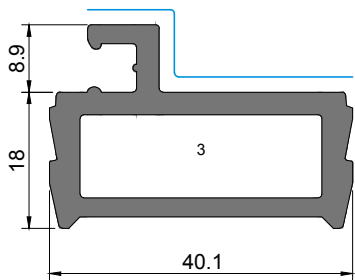

OS 47
Perfil mosquiteira
Flynet profile | Profilé pour mosquitaire

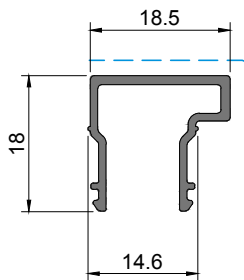

OS 48
Perfil mosquiteira
Flynet profile | Profilé pour mosquitaire

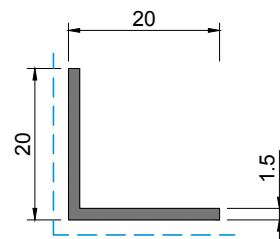

KL 20
Cantoneira
Angle bracket | Équerre de fixation

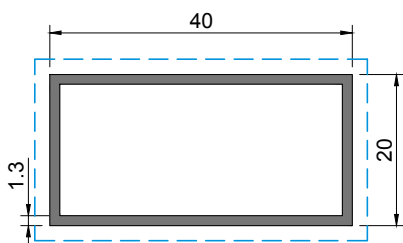

KP 42
Tubo
Tube | Tube

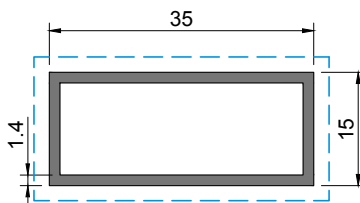

KP 35
Tubo
Tube | Tube

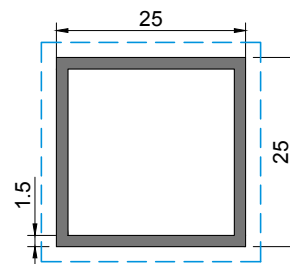

KQ 25
Tubo
Tube | Tube

1 - ESQUADRO | BRACKET | EQUÉRRE 18-1310-C

2 - ESQUADRO | BRACKET | EQUÉRRE 18-2210-D

3 - ESQUADRO | BRACKET | EQUÉRRE 18-3112-C

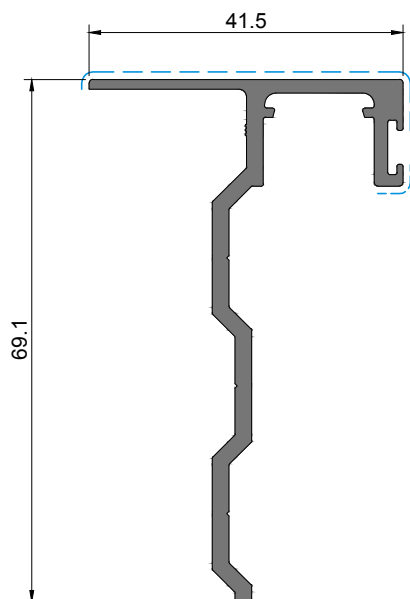

SO 45

Perfil complementar para solução de embutir

Complementary profile for pocket solution | Profilé complémentaire pour galandage

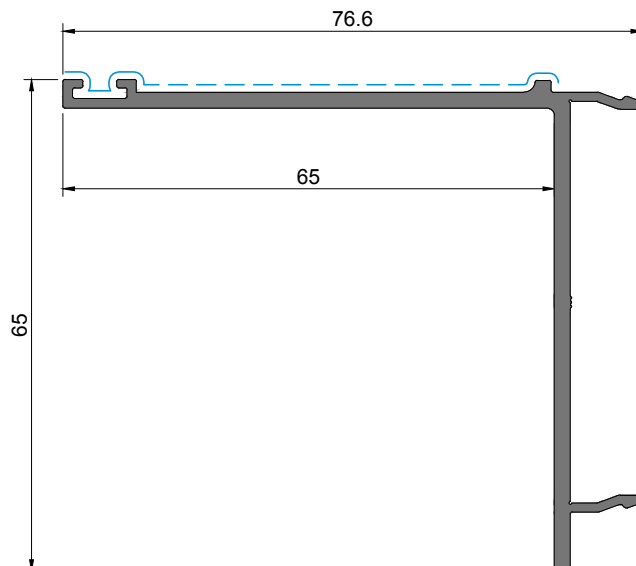

SO 46

Perfil remate para solução de embutir

Finishing profile for pocket solution | Profilé de finition pour galandage

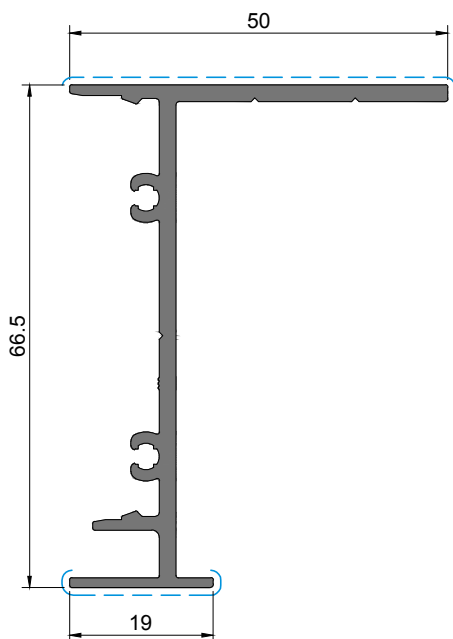

SO 47

Perfil remate para solução de embutir

Finishing profile for pocket solution | Profilé de finition pour galandage

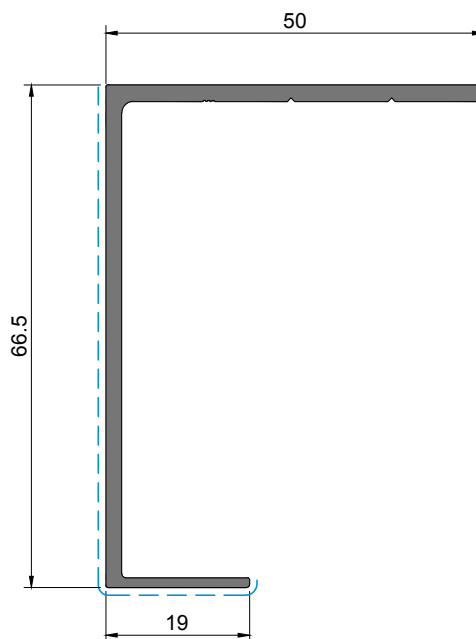

SO 48

Perfil remate para solução de embutir

Finishing profile for pocket solution | Profilé de finition pour galandage

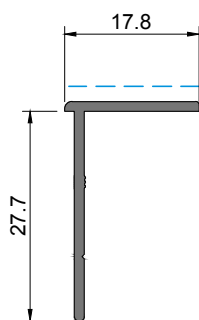

JM 81

Perfil complementar

Complementary profile | Profilé complémentaire

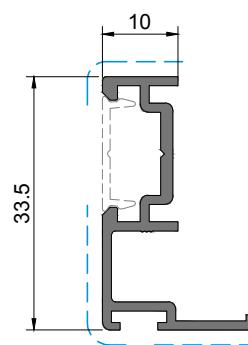

JF 66

Perfil complementar

Complementary profile | Profilé complémentaire

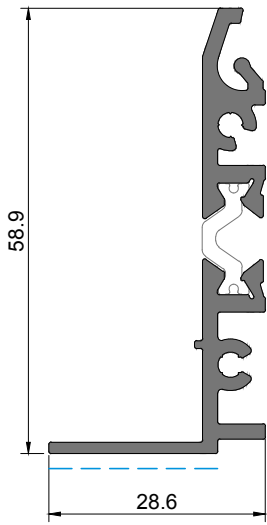

SO 80
Soleira 1-rail para caleira
1-rail Sill for drainage gutter
Seuil 1-rail pour gouttière de sol

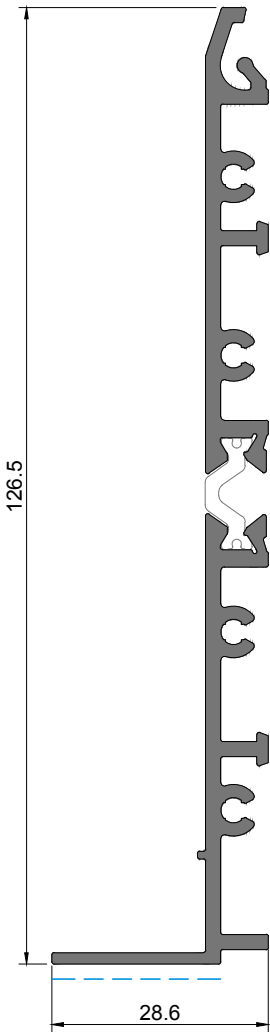

SO 82
Soleira 2-rail para caleira
2-rail Sill for drainage gutter
Seuil 2-rail pour gouttière de sol

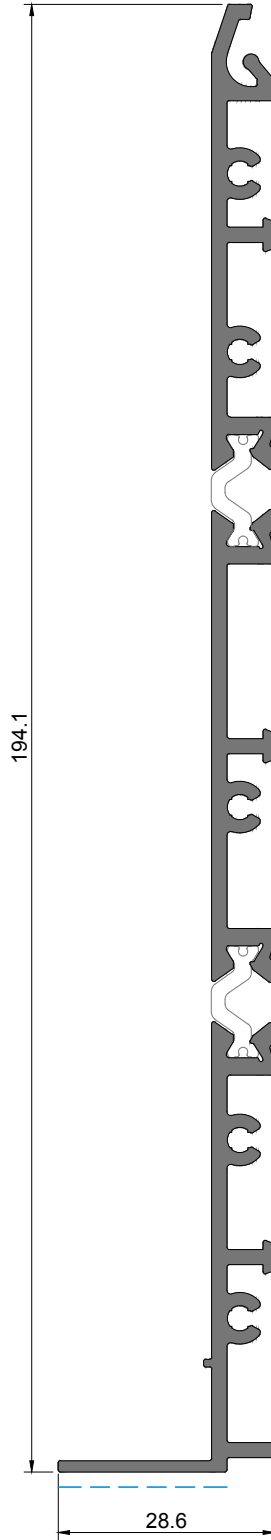

SO 84
Soleira 3-rail para caleira
3-rail Sill for drainage gutter
Seuil 3-rail pour gouttière de sol

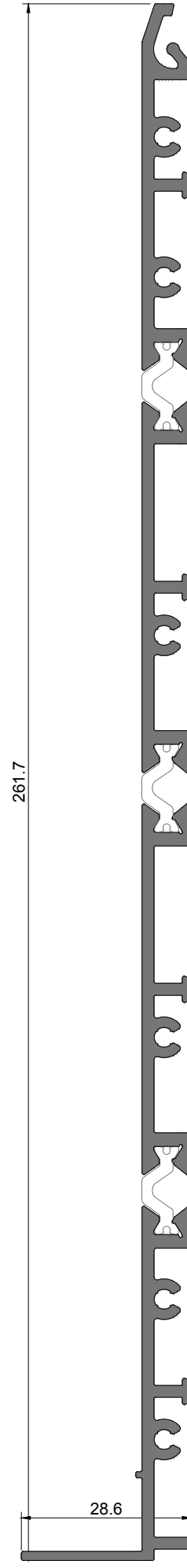

SO 83
Soleira 4-rail para caleira
4-rail Sill for drainage gutter
Seuil 4-rail pour gouttière de sol

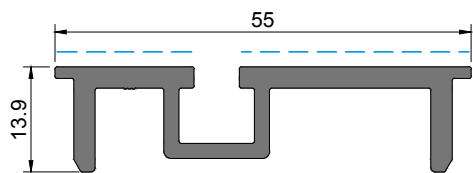

SO 26

Tampa baixa para caleira

Short drainage channel grid | Grille bas pour gouttière de vidange

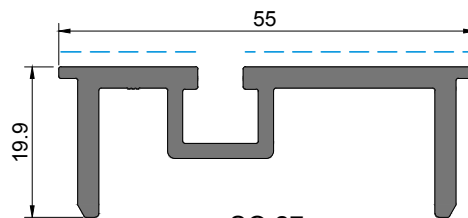

SO 27

Tampa alta para caleira

Tall drainage channel grid | Grille haute pour gouttière de vidange

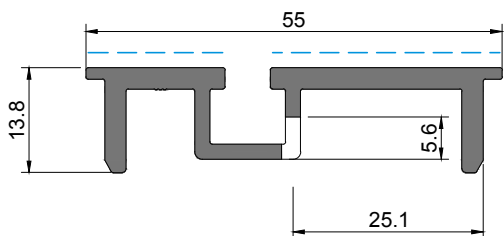

SO 58

Tampa baixa para caleira - Maquinado

Short drainage channel grid - Machined | Grille bas pour gouttière de vidange - Usiné

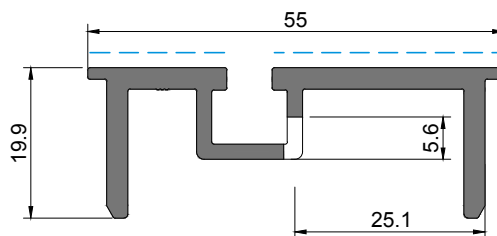

SO 59

Tampa alta para caleira - Maquinado

Tall drainage channel grid - Machined | Grille haute pour gouttière de vidange - Usiné

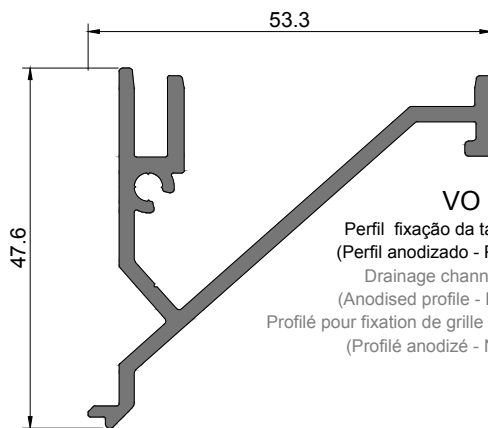

VO 11

Perfil fixação da tampa de caleira
(Perfil anodizado - Preto ou Natural)

Drainage channel grid profile
(Anodised profile - Black or Natural)

Profilé pour fixation de grille pour gouttière de vidange
(Profilé anodisé - Noir ou Naturel)

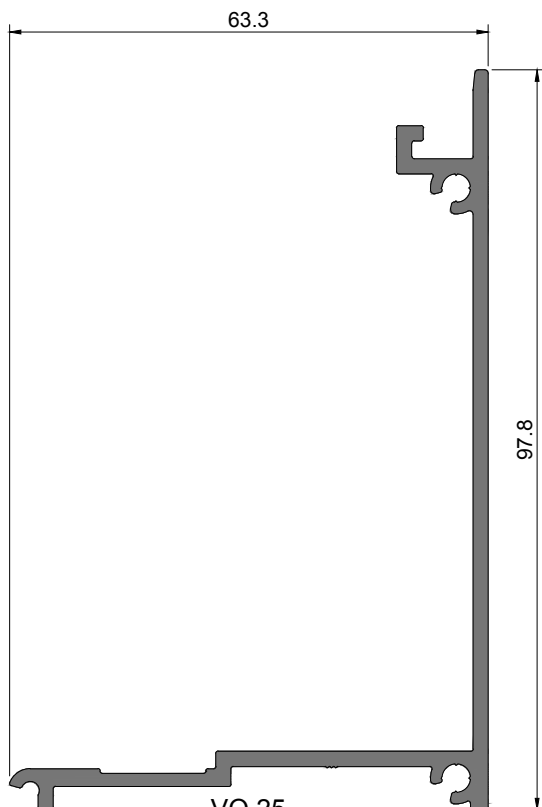

VO 25

Caleira

Drainage channel | Gouttière de vidange

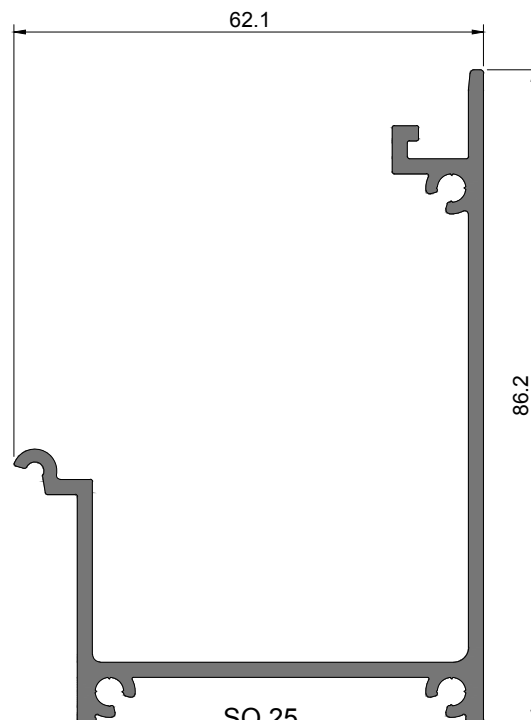

SO 25

Caleira

(Perfil anodizado - Preto ou Natural)

Drainage channel

(Anodised profile - Black or Natural)

Gouttière de vidange

(Profilé anodisé - Noir ou Naturel)

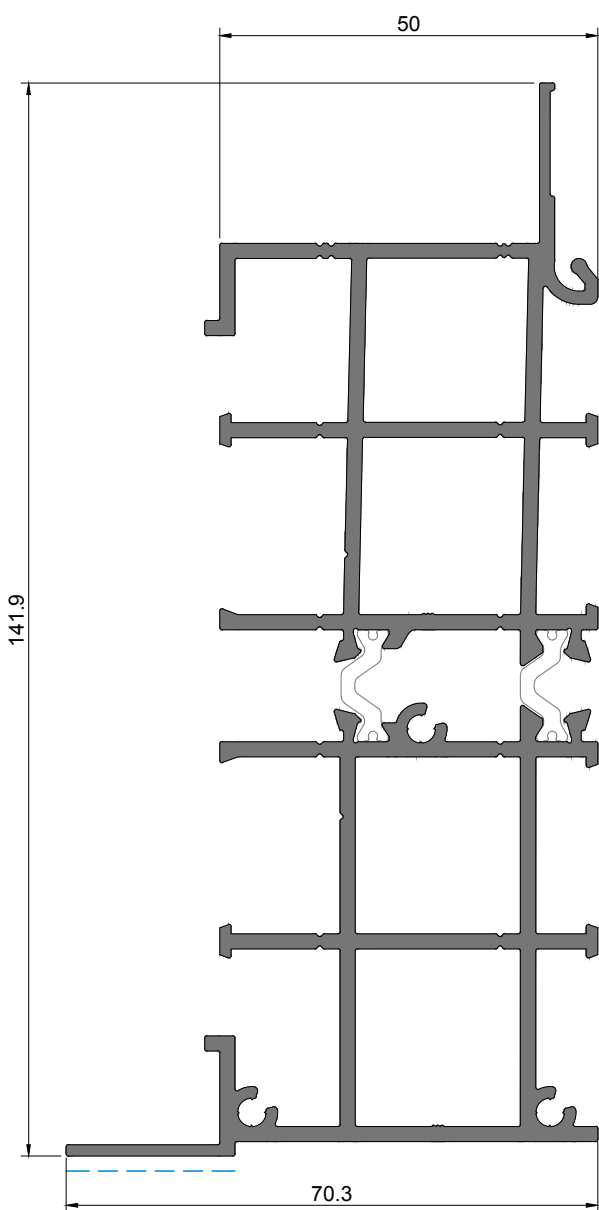

VO 22

Soleira alta 2-rail para caleira
2-rail high Sill for drainage gutter
Seuil haut 2-rail pour gouttière de sol

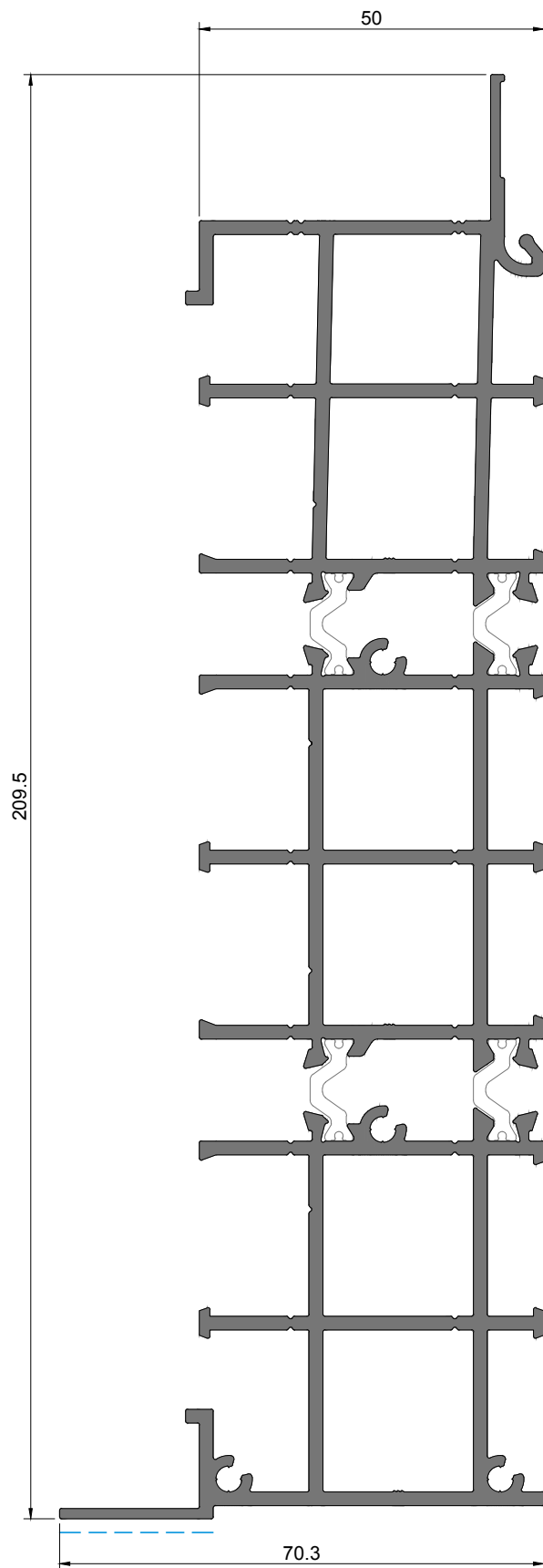

VO 23

Soleira alta 3-rail para caleira
3-rail high Sill for drainage gutter
Seuil haut 3-rail pour gouttière de sol

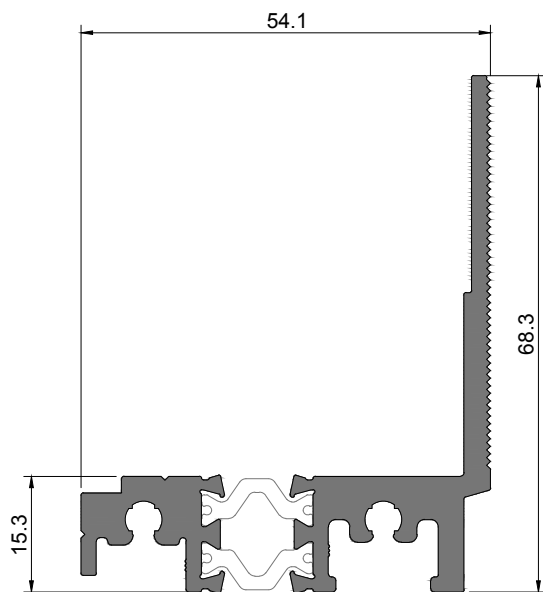

SO 98

Pré-aro 1 rail

1-rail Pre-frame profile | Profilé pré-châssis 1-rail

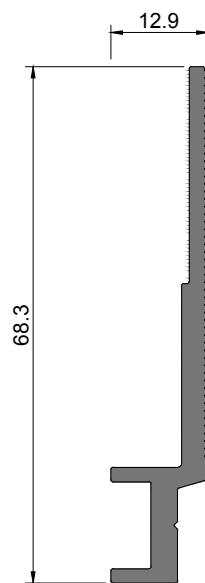

SO 89

Bite

Bead | Parclose

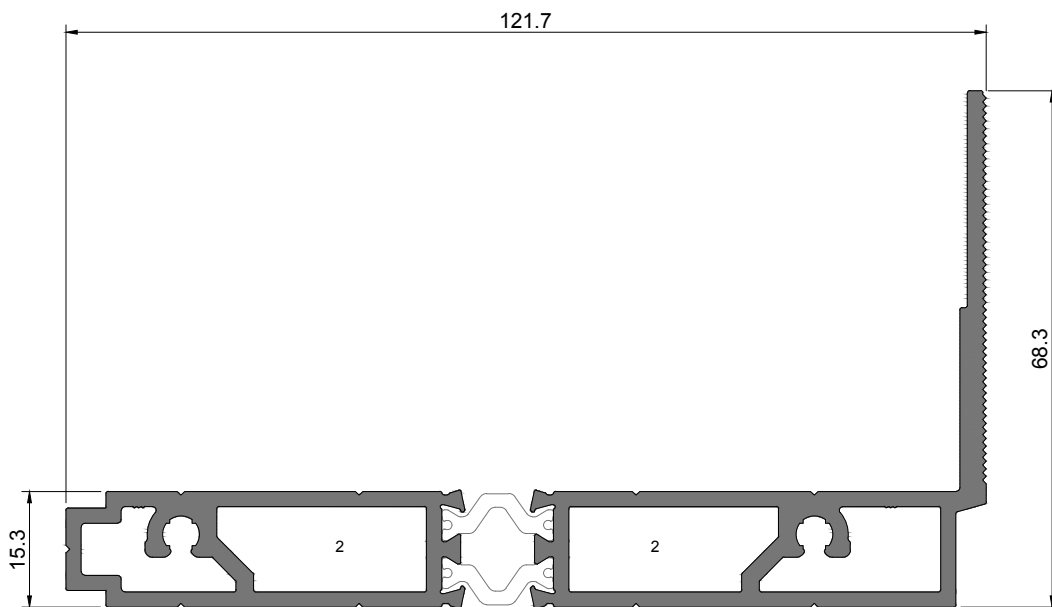

SO 90

Pré-aro 2-rail

2-rail Pre-frame profile | Profilé pré-châssis 2-rail

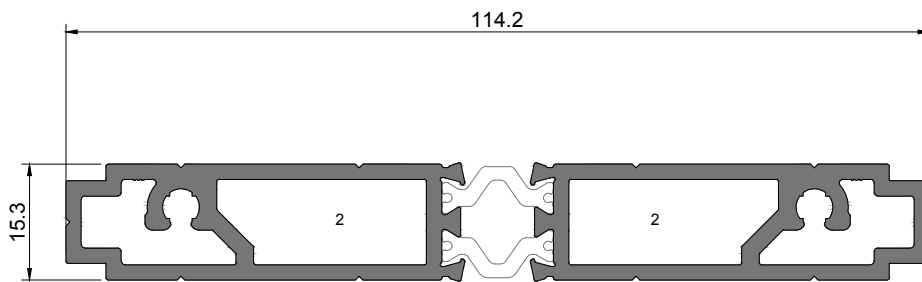

SO 91

Pré-aro 2-rail

2-rail Pre-frame profile | Profilé pré-châssis 2-rail

1 - ESQUADRO | BRACKET | EQUÉRRE 18-1310-C

2 - ESQUADRO | BRACKET | EQUÉRRE 18-2210-D

3 - ESQUADRO | BRACKET | EQUÉRRE 18-3112-C

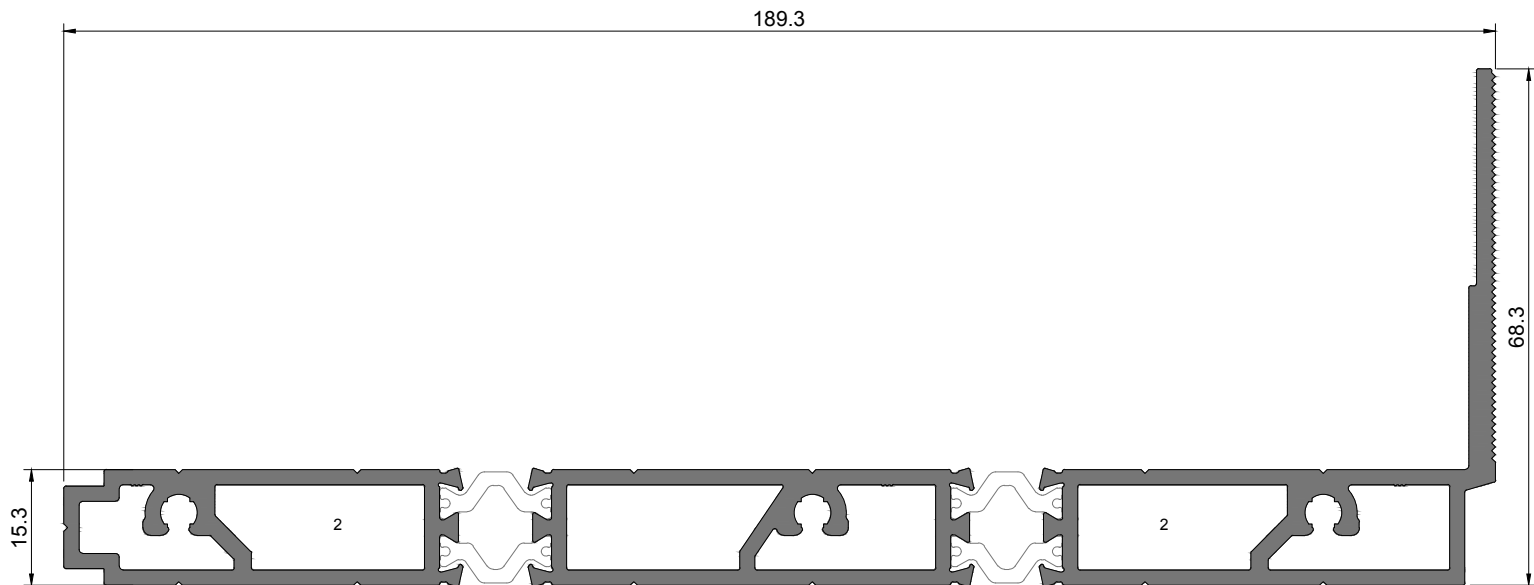

SO 92

Pré-aro 3-rail

3-rail Pre-frame profile | Profilé pré-châssis 3-rail

Tratamento de superfície | Surface treatment | Traitement de surface
 PB | PM | EF | EM PB | EF | EM
 Para mais informações, consultar Catálogo de Cores Anodizadas
 For further information, consult the Anodised Colours Catalogue | Pour plus d'informations, veuillez consulter le Catalogue des Couleurs Anodisées

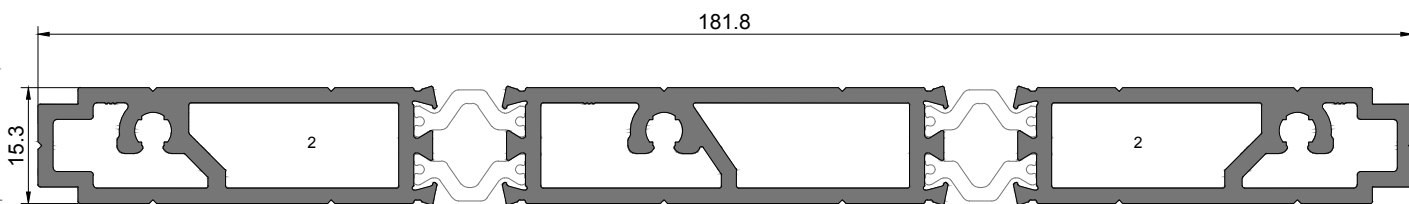

SO 93

Pré-aro 3-rail

3-rail Pre-frame profile | Profilé pré-châssis 3-rail

1 - ESQUADRO | BRACKET | EQUÉRRE 18-1310-C

2 - ESQUADRO | BRACKET | EQUÉRRE 18-2210-D

3 - ESQUADRO | BRACKET | EQUÉRRE 18-3112-C

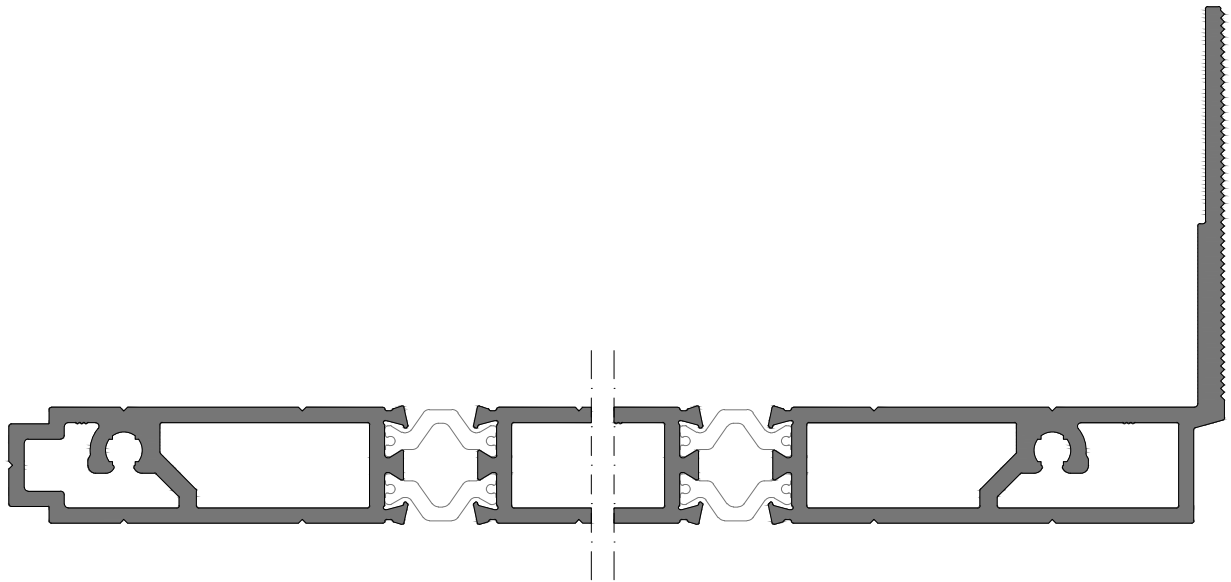

SO 68

Pré-aro 4-rail

4-rail Pre-frame profile | Profilé pré-châssis 4-rail

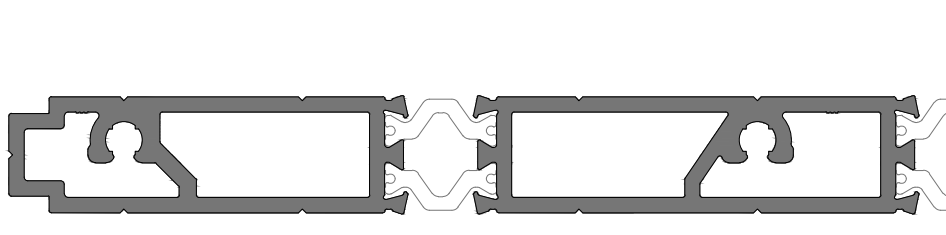
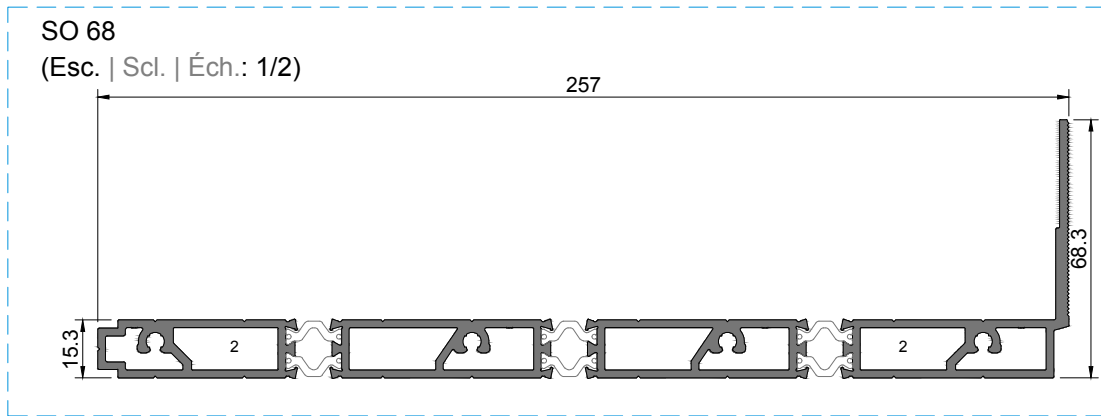

SO 69

Pré-aro 4-rail

4-rail Pre-frame profile | Profilé pré-châssis 4-rail

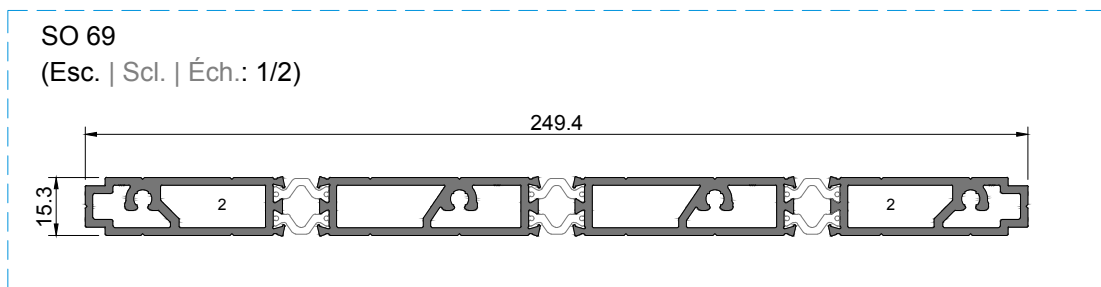

1 - ESQUADRO | BRACKET | EQUÉRRE 18-1310-C

2 - ESQUADRO | BRACKET | EQUÉRRE 18-2210-D

3 - ESQUADRO | BRACKET | EQUÉRRE 18-3112-C

Tratamento de superfície | Surface treatment | Traitement de surface
 PB | PM | EF | EM PB | EF | EM
 Para mais informações, consultar Catálogo de Cores Anodizadas
 For further information, consult the Anodised Colours Catalogue | Pour plus d'informations, veuillez consulter le Catalogue des Couleurs Anodisées

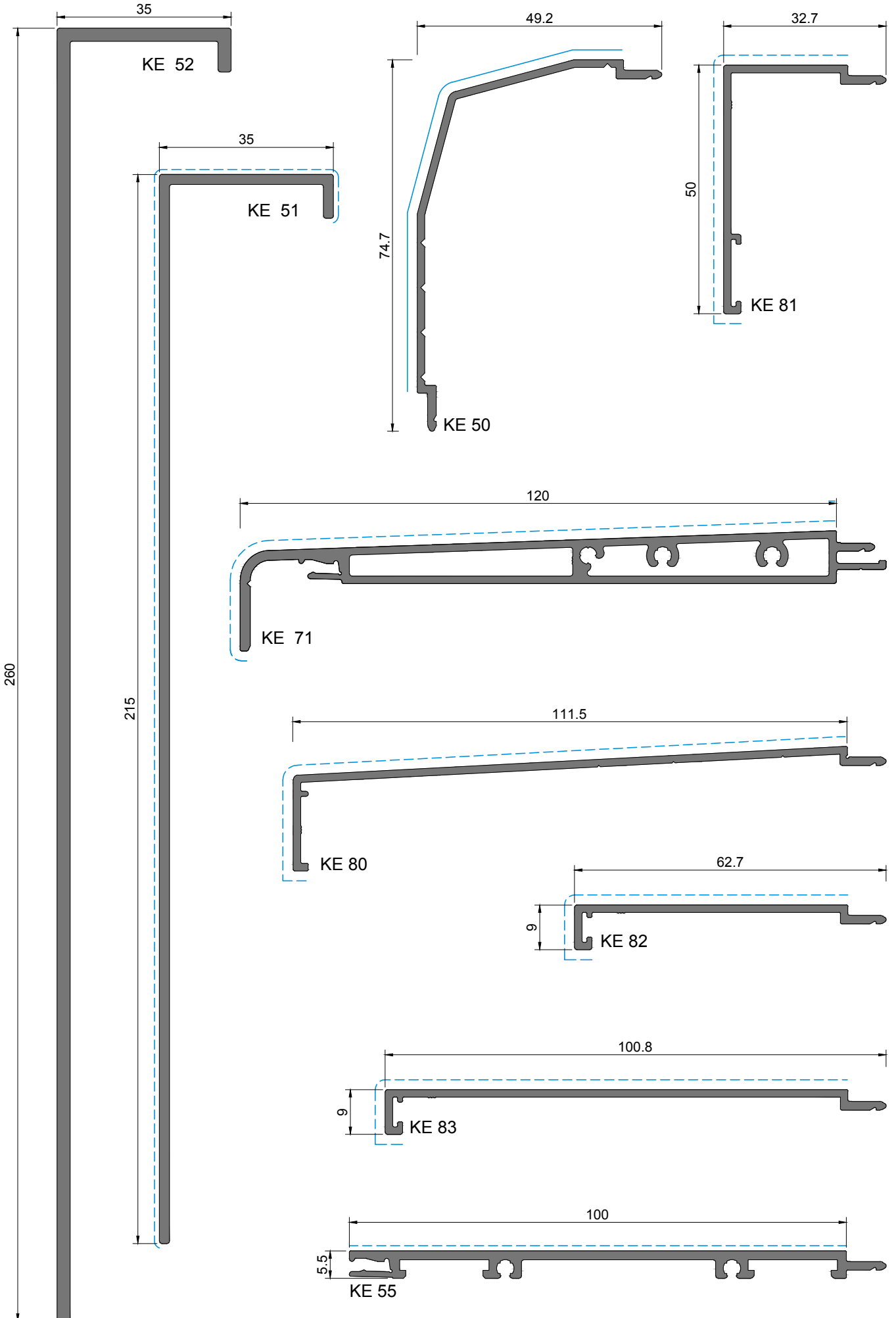

Treatmento de superfície | Surface treatment | Traitement de surface
 PB | PM | EF | EM PB | EF | EM
 Para mais informações, consultar Catálogo de Cores Anodizadas
 For further information, consult the Anodised Colours Catalogue | Pour plus d'informations, veuillez consulter le Catalogue des Couleurs Anodisées

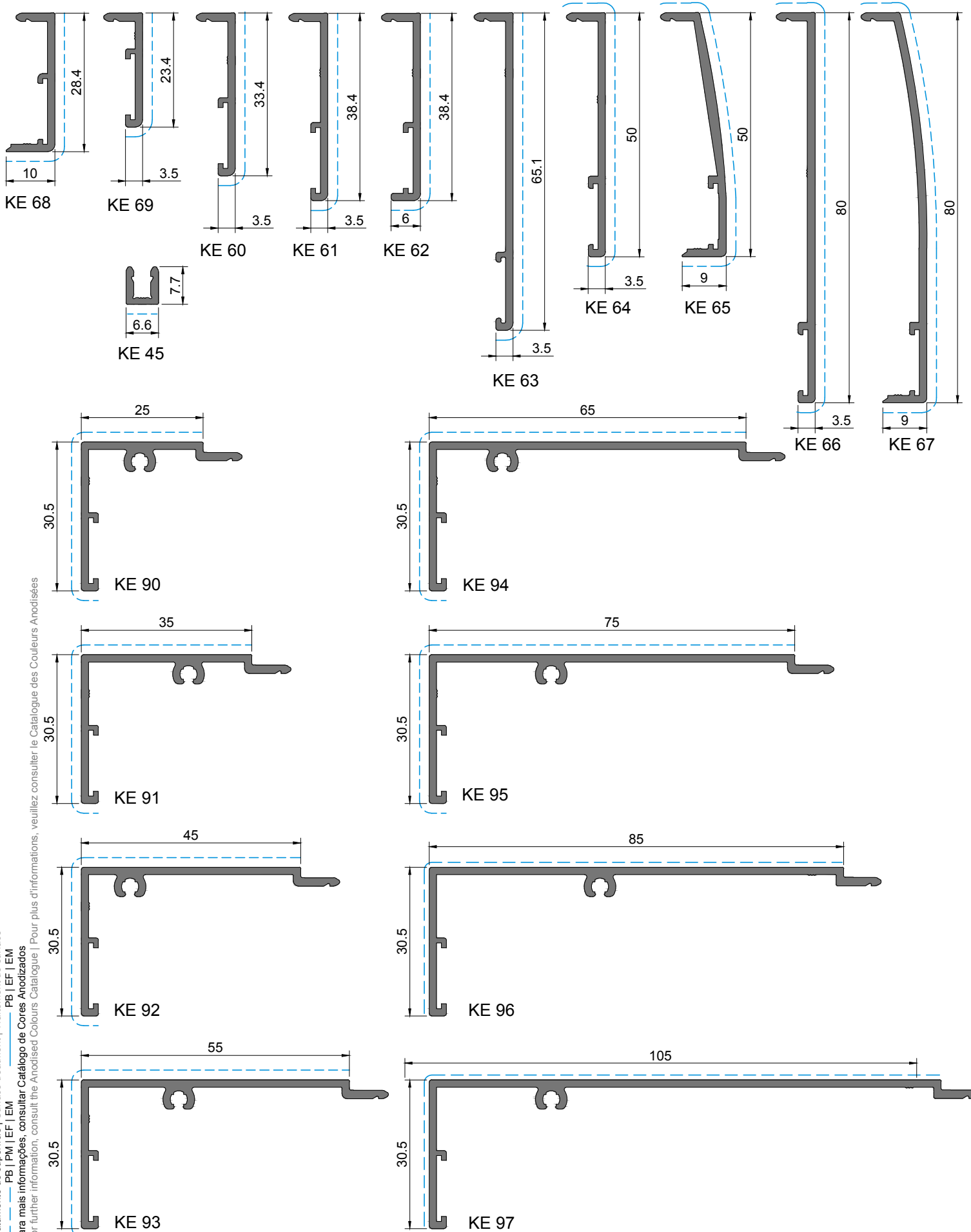

Treatmento de superficie | Surface treatment | Traitement de surface
 PB | PM | EF | EM PB | EF | EM
 Para mais informações, consultar Catálogo de Cores Anodizadas
 For further information, consult the Anodised Colours Catalogue | Pour plus d'informations, veuillez consulter le Catalogue des Couleurs Anodisées



Casa 1441 | Portugal | P150, Arquitectos e Engenheiros, Lda | Fotografia MAI Studio, Arquitetura e Imagem



LISTAGEM DE ACESSÓRIOS
ACCESSORIES LIST | LIST D'ACCESSOIRES

VEDANTES E PELÚCIAS
SEALS AND GASKETS | JOINTS ET JOINTS BROSSES

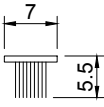

Aplicar apenas nas larguras e nos perfis SO 38 e SO 39
Rolo: 325m

208450 PELÚCIA 7x5.5 Cinza
208465 PELÚCIA 7x5.5 Preta

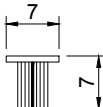

Aplicar apenas nas alturas
Ref. 208460 97111 - Cinza
Ref. 208460 99951 - Preto
Rolo: 300m

208460 PELÚCIA 7x7 STOP-FIN Cinza/Preto

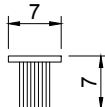

Aplicar nos perfis OS 08 e OS 18
Rolo: 225m

208458 PELÚCIA 7x7 Cinza
208467 PELÚCIA 7x7 Preta

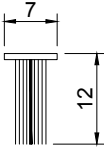

Para o perfil SO 46
Rolo: 300m

208593 PELÚCIA 7x12 STOP-FIN Cinza
208466 PELÚCIA 7x12 STOP-FIN Preta

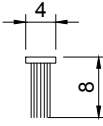

Para Soleira Oculta e SO 37
Rolo: 500m

208468 PELÚCIA SRF 4X8 2P1M Cinza
208469 PELÚCIA SRF 4X8 2P1M Preta

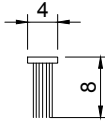

Para aplicar nos topos centrais, na
vertente de Soleira Tradicional
Acabamentos: Cinza e Preto
Unidade (comprimento: 100mm)

208597 PELÚCIA SRF 4X8X100 2P1M



Material: EPDM com 2 durezas
Zona de batente: EPDM esponjoso
Base: EPDM 70Sh | Acabamento: Preto
Caixa: 300m (150m + 150m)

208225 JUNTA DE ESTANQUIDADE 2050

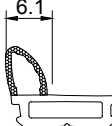

Material: EPDM
Rolo: 150m

208499 JUNTA VEDAÇÃO 2063N



Para o perfil OS 87
Material: EPDM 90° Shore

208186 JUNTA VD 2075



Barra: 6,50m | Material: EPDM 90Sh

208193 JUNTA VD 2060



Aplicar em soluções 1-Rail OS
Rolo: 20m | Material: EPDM 90Sh | Acabamento: Preto

208203 JUNTA VD 2082

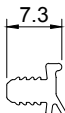

Para o perfil OS 87 - Usar com vidro 8.8.2
Material: EPDM 90° Shore

208187 JUNTA VD 2076

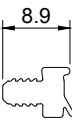

Para o perfil OS 87 - Usar com vidro 6.6.2
Material: EPDM 90° Shore

208188 JUNTA VD 2077



Para o perfil OS 87 - Usar com vidro 4.4.2
Material: EPDM 90° Shore

208207 JUNTA VD 2078



Para soluções de vão fixo com SO 15
Material: EPDM
Rolo: 200m

208199 JUNTA DE CUNHA 2073

VEDANTES E PELÚCIAS
SEALS AND GASKETS | JOINTS ET JOINTS BROSSES

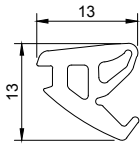

Para soluções de vão fixo com SO 15
Para caixa de vidro de 8 a 10mm
Material: EPDM
Caixa: 100m

208912 JUNTA DE CUNHA RECORTADA 4193

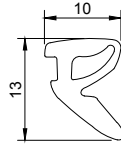

Para soluções de vão fixo com SO 15
Para caixa de vidro de 6 a 7mm
Material: EPDM
Caixa: 150m

208913 JUNTA DE CUNHA RECORTADA 4194

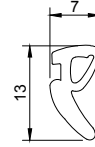

Para soluções de vão fixo com SO 15
Para caixa de vidro de 3 a 4mm
Material: EPDM
Caixa: 200m

208914 JUNTA DE CUNHA RECORTADA 4195

ACESSÓRIOS PARA VIDRO
GLASS ACCESSORIES | ACCESSOIRES POUR VERRE

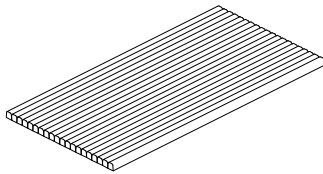

Para soluções de aro fixo com o perfil SO 15

218109 CALÇO P/VIDRO 79x40x3
GLASS SUPPORT 79x40x3
CALES À VIDRAGE 79x40x3

GOTEIRAS
DRIPS | GOUTTIÈRES

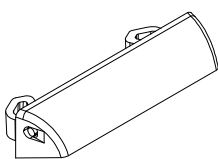

Acabamento: Preto e Branco
210268 GOTEIRA C/ VÁLV. SVE

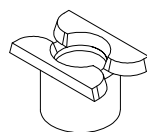

Acabamento: Preto
Acabamento: Preto e Transparente
210265 GOTEIRA COM VÁLVULA BOLA

ACESSÓRIOS PARA OS AROS
FRAME ACCESSORIES | ACCESSOIRES POUR LES CADRES

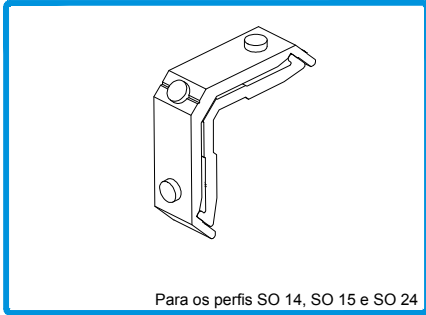

Para os perfis SO 14, SO 15 e SO 24

205173 ESQUADRO 18-1310-C

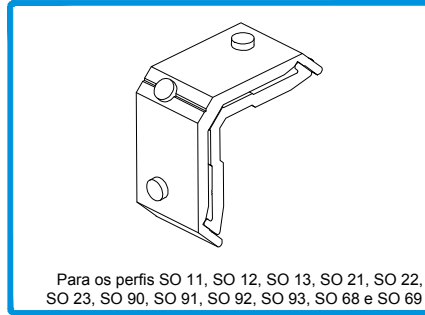

Para os perfis SO 11, SO 12, SO 13, SO 21, SO 22, SO 23, SO 90, SO 91, SO 92, SO 93, SO 68 e SO 69

205172 ESQUADRO 18-2210-D

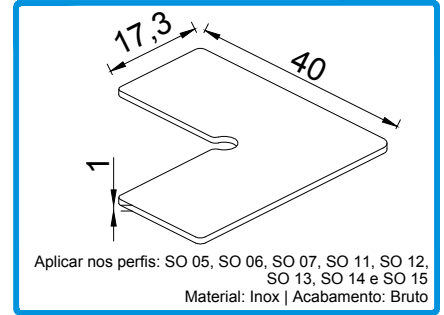

Aplicar nos perfis: SO 05, SO 06, SO 07, SO 11, SO 12, SO 13, SO 14 e SO 15
Material: Inox | Acabamento: Bruto

213018 CANTO DE ALINHAMENTO OS Nº2

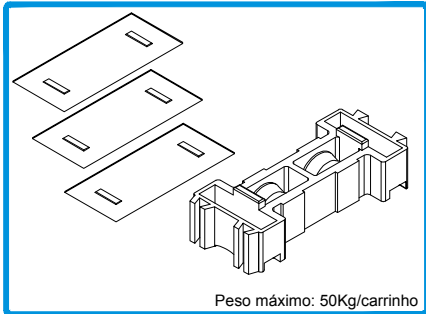

Peso máximo: 50Kg/carrinho

212099 CARRINHO OS

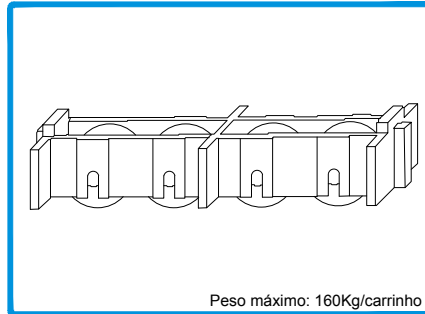

Peso máximo: 160Kg/carrinho

205121 CARRINHO OS 4 RODAS INOX

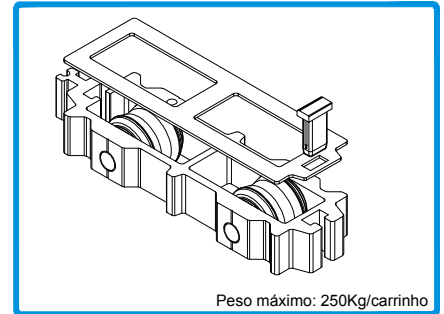

Peso máximo: 250Kg/carrinho

205162 CARRINHO OS Nº. 5

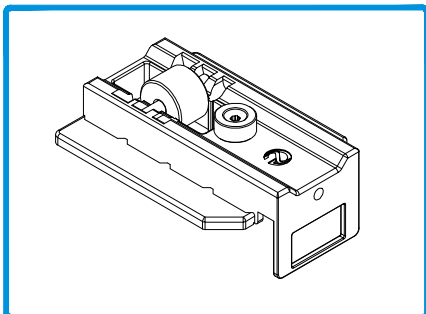

205161 CARRINHO-GUIA OS SUPERIOR Nº3

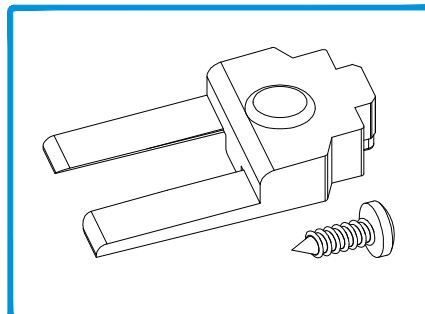

215078 PEÇA ANTI-LEVANTAMENTO OS

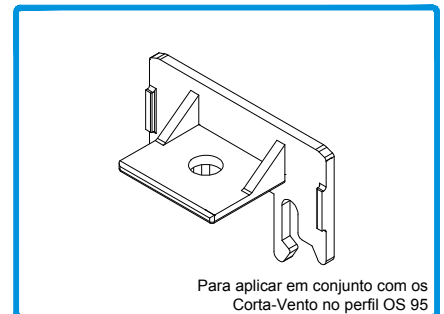

Para aplicar em conjunto com os Corta-Vento no perfil OS 95

210510 TOPO BLOQUEIO PELÚCIA CV

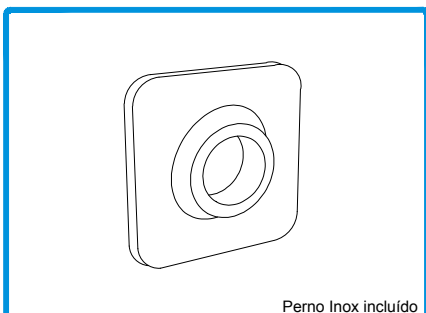

Perno Inox incluído

215194 CHAPA BLOQUEIO PELÚCIA

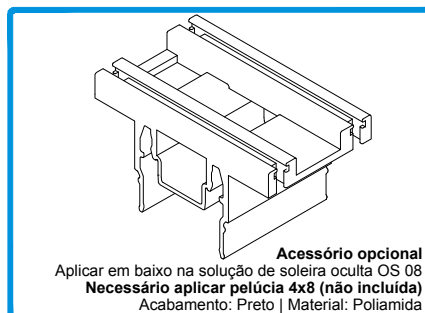

Acessório opcional
Aplicar em baixo na solução de soleira oculta OS 08
Necessário aplicar pelúcia 4x8 (não incluída)
Acabamento: Preto | Material: Poliamida

213281 CORTA VENTO SOL. OCULTA OS 08

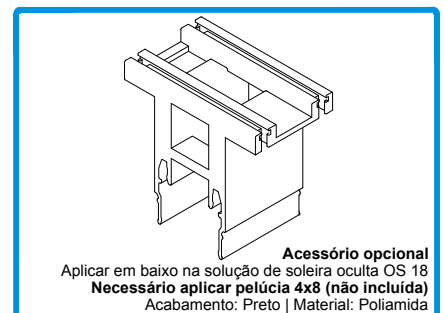

Acessório opcional
Aplicar em baixo na solução de soleira oculta OS 18
Necessário aplicar pelúcia 4x8 (não incluída)
Acabamento: Preto | Material: Poliamida

213275 CORTA VENTO SOL. OCULTA OS 18

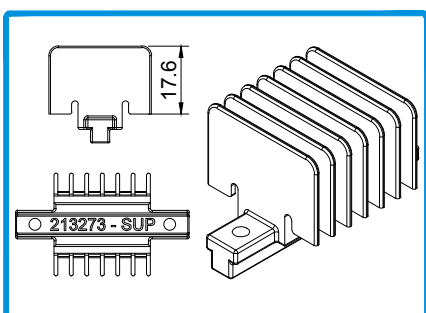

213273 CORTA VENTO SUPERIOR OS

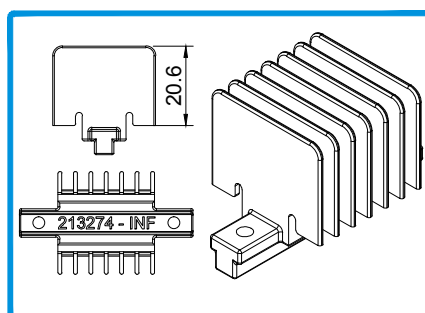

213274 CORTA VENTO INFERIOR OS

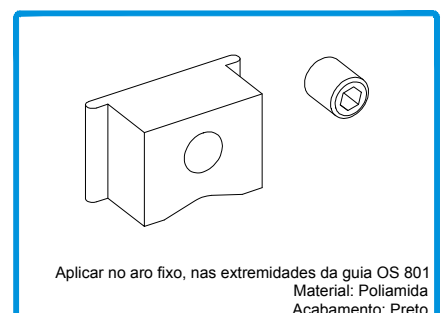

Aplicar no aro fixo, nas extremidades da guia OS 801
Material: Poliamida
Acabamento: Preto

215083 ANTI-LEVANTAMENTO GUIA INOX OS

ACESSÓRIOS PARA OS AROS
FRAME ACCESSORIES | ACCESSOIRES POUR LES CADRES

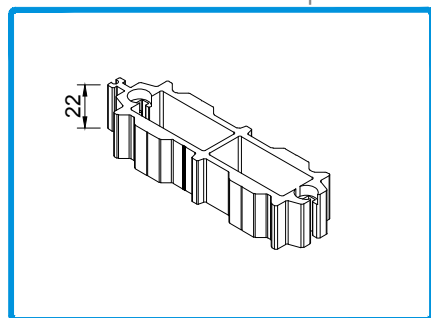

218134 CALÇO FIXO OS-DOUBLE

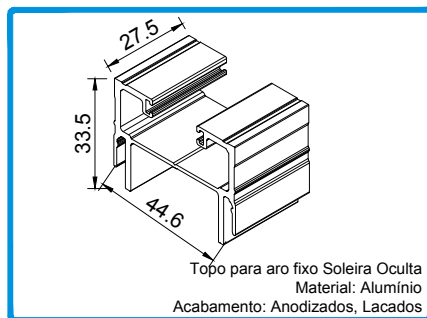

210159 TOPO ARO FIXO SOLEIRA OCVLTA V2 - Nº2
Material: Alumínio | Acabamento: Anodizados, Lacados

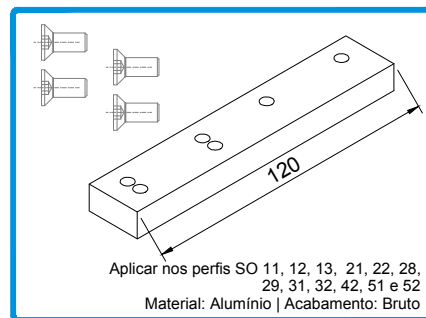

212953 CONJ. UNIÃO RETA OS

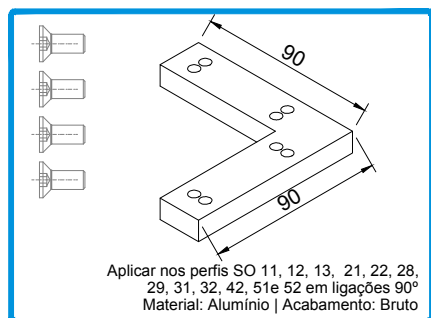

212954 CONJ. UNIÃO CANTO 90º OS

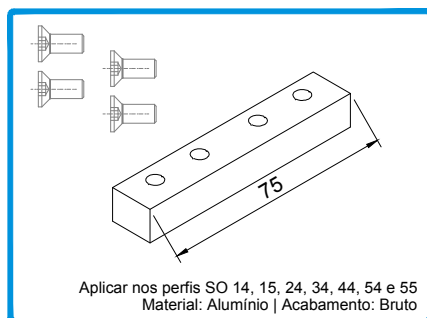

212956 CONJ. UNIÃO RETA 1-RAIL OS

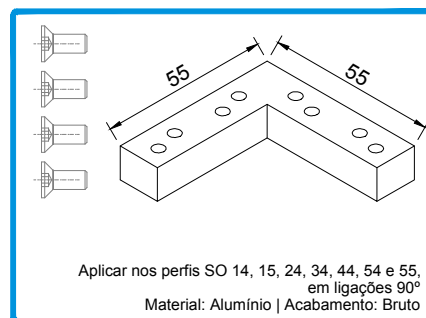

212957 CONJ. UNIÃO CANTO 90º 1-RAIL OS

ACESSÓRIOS PARA AROS MÓVEIS LATERAIS
LATERAL MOBILE FRAMES ACCESSORIES | ACCESSOIRES POUR CADRES OUVRANTS LATÉRAUX

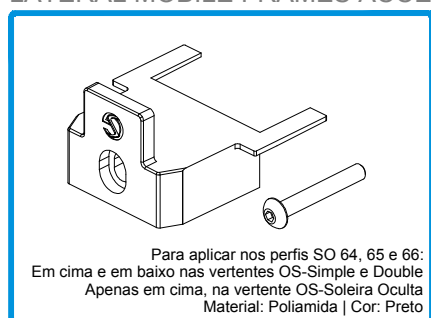

210165 TOPO LATERAL SUP. INF. Nº15 OS-V2

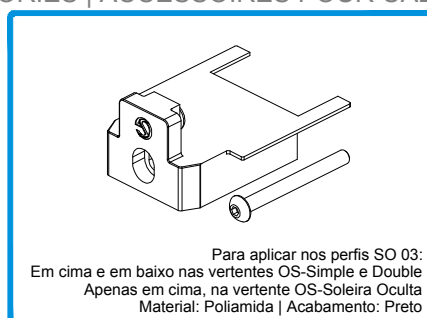

210193 TOPO LATERAL SUP. INF. Nº21 OS-D FECH.

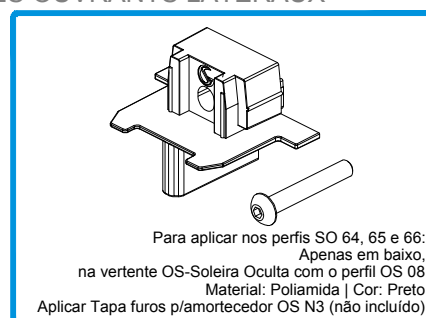

210166 TOPO LATERAL INF. 20MM Nº16 OS-V2 SOL. INVIS.

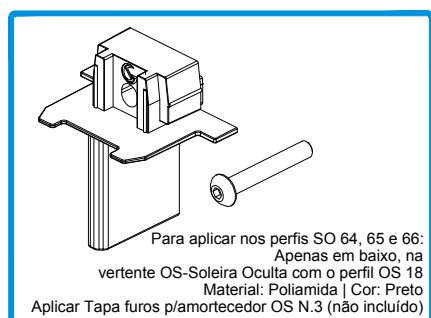

210167 TOPO LATERAL INF. 40mm Nº17 OS-V2 SOL. INVIS.

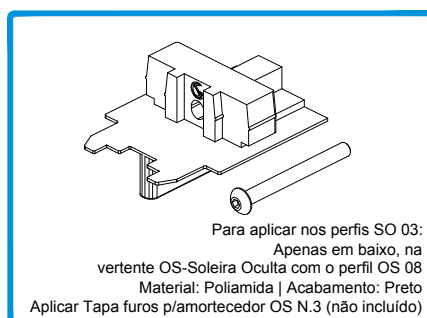

210194 TOPO LAT. INF. 20MM Nº22 OS-D SOL. INVIS. FECH.

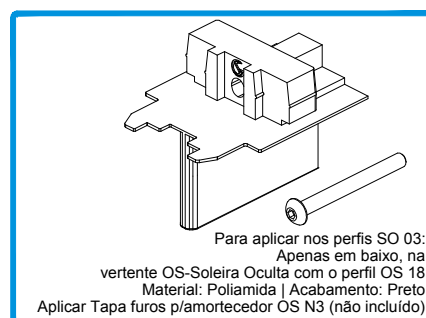

210195 TOPO LAT. INF. 40MM Nº23 OS-D SOL. INVIS. FECH.

ACESSÓRIOS PARA AROS MÓVEIS CENTRAIS

CENTRAL MOBILE FRAMES ACCESSORIES | ACCESSOIRES POUR CADRES OUVRANTS CENTRAUX

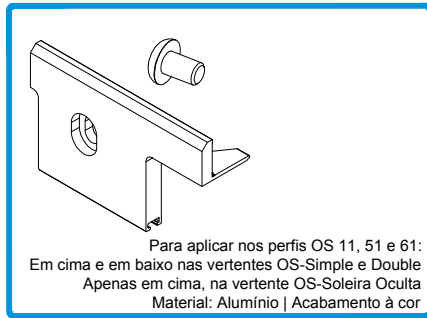

210094 TOPO CENTRAL Nº2 OS V2 ESQUERDO

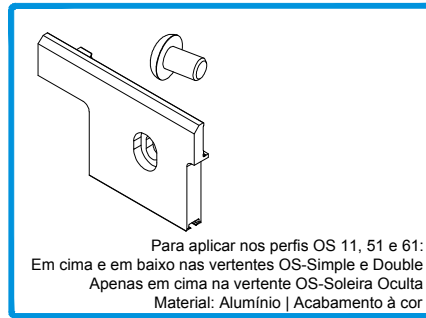

210095 TOPO CENTRAL Nº2 OS V2 DIREITO

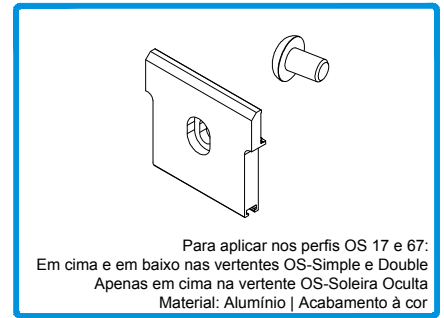

210096 TOPO CENTRAL INVERTIDO Nº. 4 OS-V2

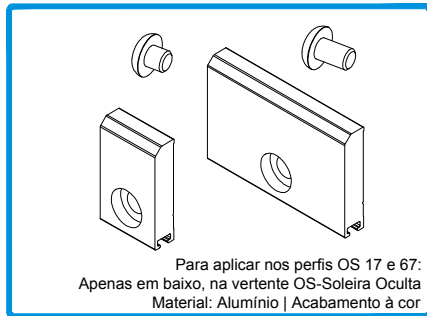

212451 CONJUNTO TOPO CENTRAL INV. Nº8 OS V2 SOL OCULTA

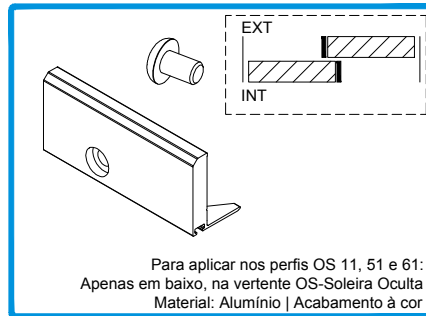

210125 TOPO CENTRAL Nº6 OS V2 SOL OCULTA ESQUERDO

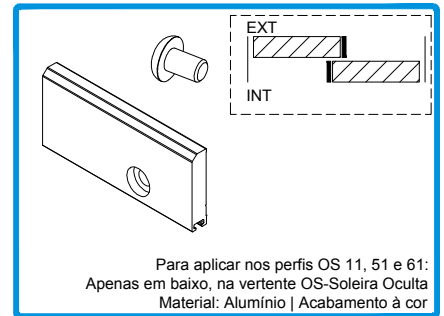

210126 TOPO CENTRAL Nº6 OS V2 SOL OCULTA DIREITO

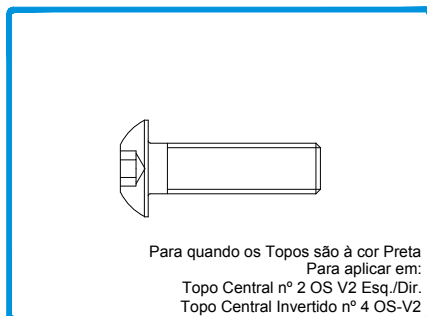

290041 PARAFUSO 7380 M5x8 INOX PRETO

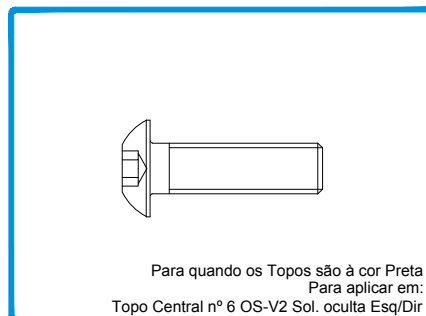

290042 PARAFUSO 7380 M5x16 INOX PRETO

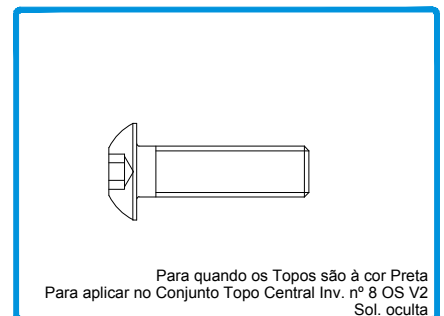

290040 PARAFUSO 7380 M5x6 INOX PRETO

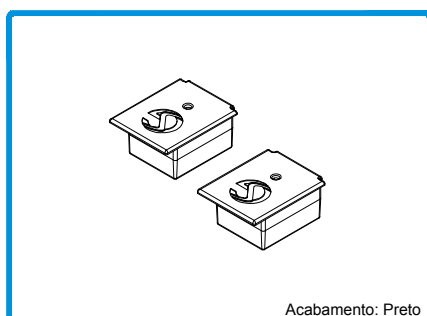

212065 CONJUNTO TOPOS OS 51

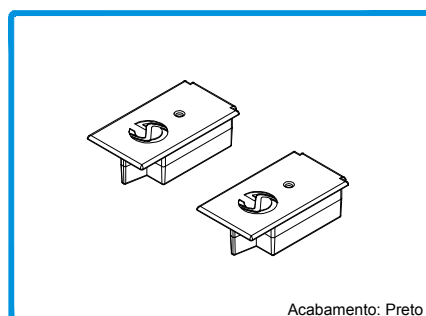

212066 CONJUNTO TOPOS OS 61

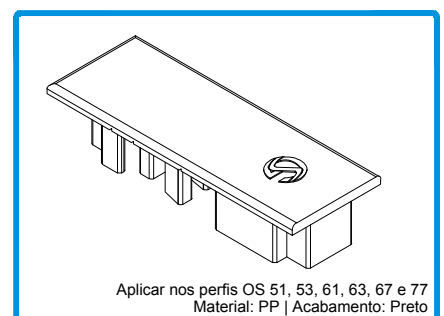

210109 TOPO OS 63 PRT

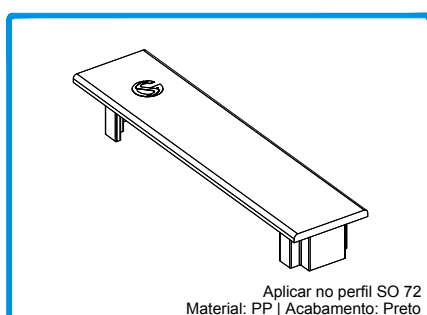

210161 TOPO SO72/SO73 PRT

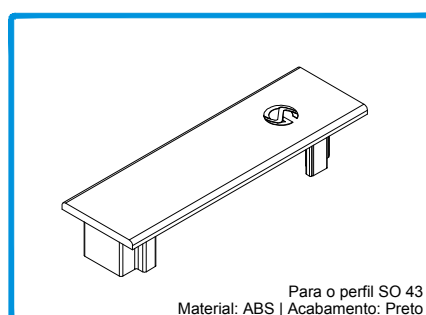

210196 TOPO SO 43 PRT

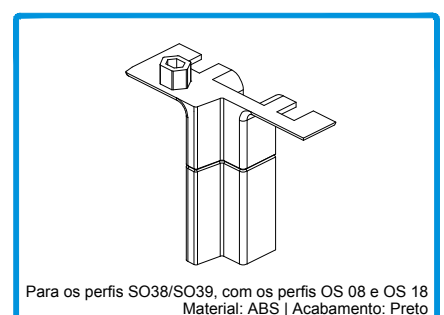

210227 TOPO INF. SOL. OCULTA SO38/SO39

ACESSÓRIOS PARA LIGAÇÃO DE CANTO
CORNER CONNECTION ACCESSORIES | ACCESSOIRES DE CONNEXION EN ANGLE

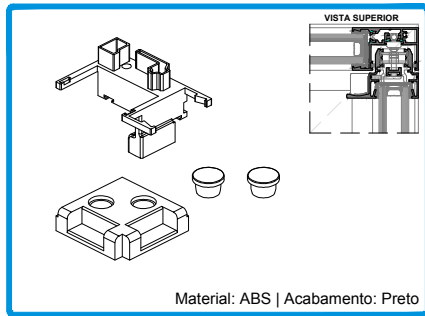

Material: ABS | Acabamento: Preto
212297 CONJ. TOPOS SUP/INF SO 10 DIREITO PRT

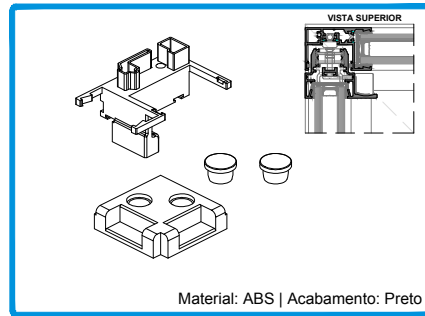

Material: ABS | Acabamento: Preto
212299 CONJ. TOPOS SUP/INF SO 10 ESQUERDO PRT

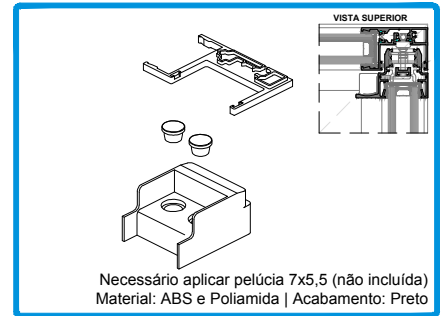

Necessário aplicar película 7x5,5 (não incluída)
Material: ABS e Poliamida | Acabamento: Preto
212393 CONJ. TOP. SUP/INF CANTO FIXO SO 10 DRT.

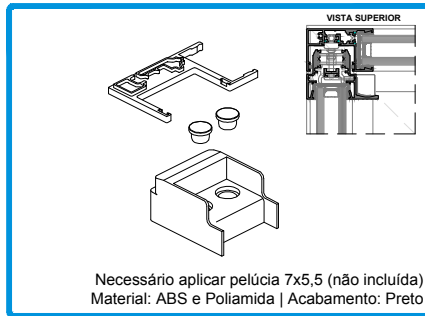

Necessário aplicar película 7x5,5 (não incluída)
Material: ABS e Poliamida | Acabamento: Preto
212394 CONJ. TOP. SUP/INF CANTO FIXO SO 10 ESQ

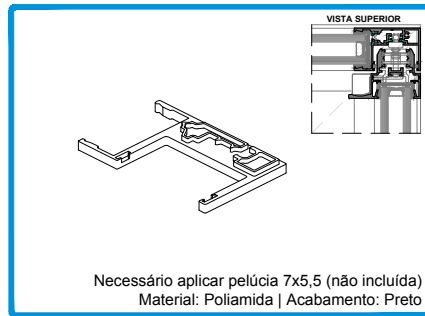

Necessário aplicar película 7x5,5 (não incluída)
Material: Poliamida | Acabamento: Preto
210221 TOPO INF SOL. OCULTA SO 10 DRT.

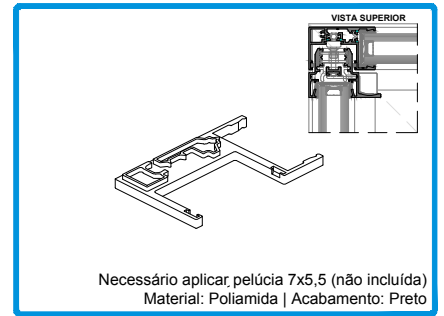

Necessário aplicar película 7x5,5 (não incluída)
Material: Poliamida | Acabamento: Preto
210223 TOPO INF SOL. OCULTA SO 10 ESQ.

ACESSÓRIOS PARA PERFIS DE REFORÇO
REINFORCEMENT PROFILES ACCESSORIES | ACCESSOIRES POUR PROFILÉS DE RENFORCEMENT

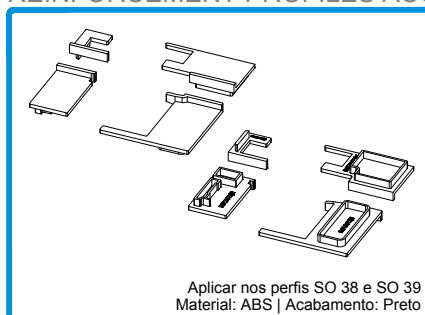

Aplicar nos perfis SO 38 e SO 39
Material: ABS | Acabamento: Preto
212019 CONJ. TOPOS SO38/SO39

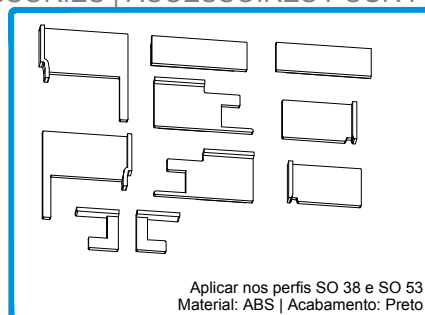

Aplicar nos perfis SO 38 e SO 53
Material: ABS | Acabamento: Preto
212159 CONJ. TOPOS SO38/SO53

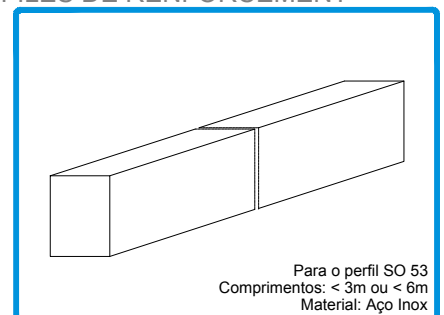

Para o perfil SO 53
Comprimentos: < 3m ou < 6m
Material: Aço Inox
215218 BARRA RECT INOX 40X10MM (3M)
215214 BARRA RECT INOX 40X10MM (6M)

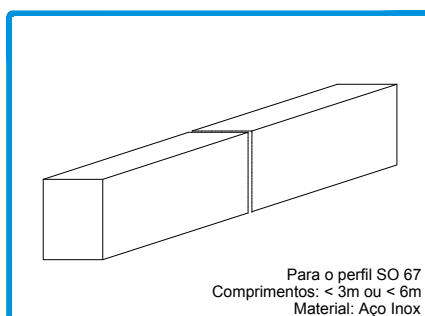

Para o perfil SO 67
Comprimentos: < 3m ou < 6m
Material: Aço Inox
215217 BARRA RECT INOX 50X10MM (3M)
215213 BARRA RECT INOX 50X10MM (6M)

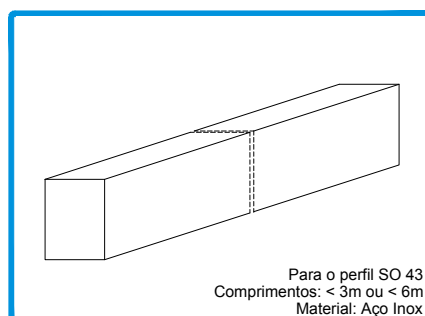

Para o perfil SO 43
Comprimentos: < 3m ou < 6m
Material: Aço Inox
215219 BARRA RECT INOX 60x10MM (3M)
215215 BARRA RECT INOX 60x10MM (6M)

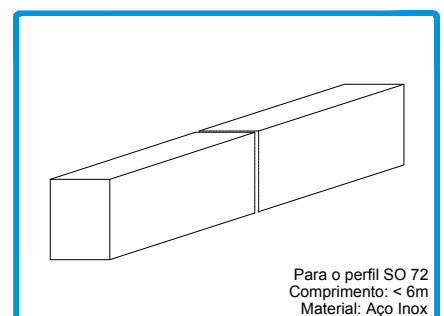

Para o perfil SO 72
Comprimento: < 6m
Material: Aço Inox
215216 BARRA RECT INOX 80x10MM (3M)
215212 BARRA RECT INOX 80x10MM (6M)

ACESSÓRIOS PARA LIGAÇÃO 2 FOLHAS

2 LEAVES CONNECTION ACCESSORIES | ACCESSOIRES POUR CONNEXION 2 VANTAUX

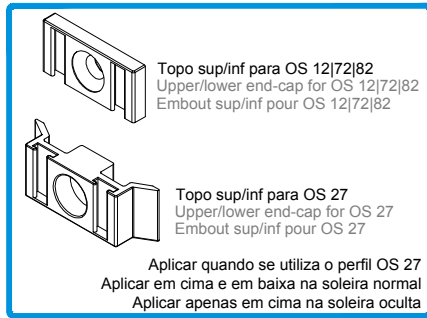

212124 CONJUNTO TOPOS PARA OS 27

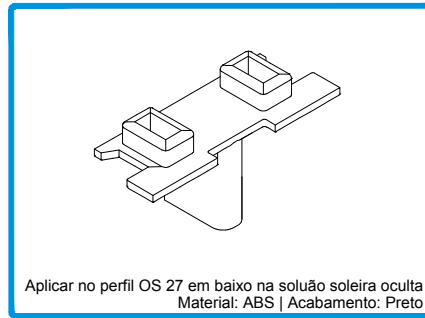

210233 TOPO INF. SOL. OCULTA OS 27

TOPOS DE AROS BAIXOS PARA SOLEIRA

LOW FRAME SILL END-CAPS | EMBOUTS DE DORMANT BAS POUR SEUIL

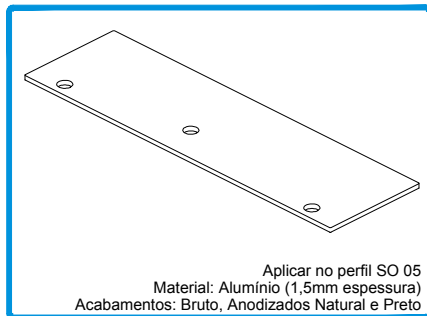

210255 TOPO PARA SO 05

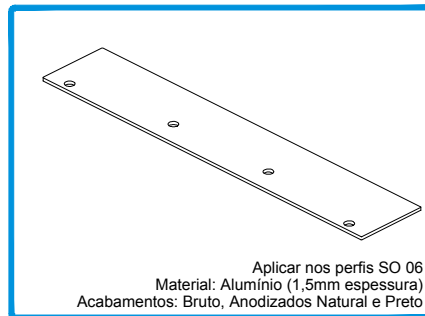

210256 TOPO PARA SO 06

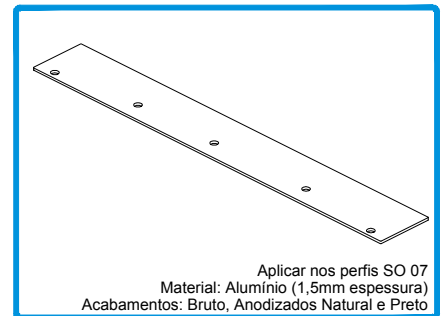

210257 TOPO PARA SO 07

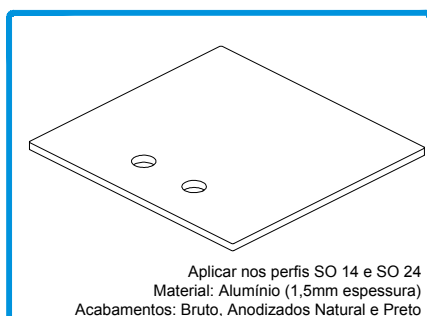

210065 TOPO PARA SO14/SO24

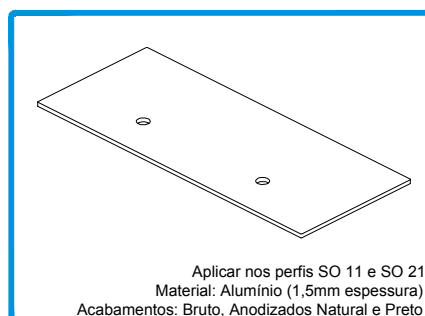

210054 TOPO PARA SO11/SO21

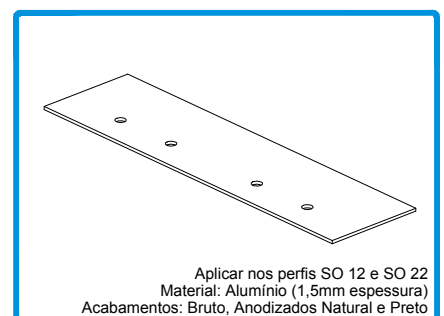

210131 TOPO PARA SO12/SO22

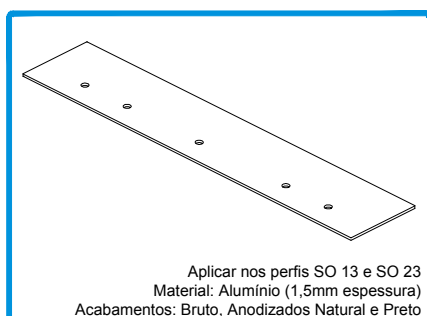

210055 TOPO PARA SO13/SO23

ACESSÓRIOS PARA SOLEIRAS/CALEIRAS

DRAINAGE CHANNEL/GUTTER ACCESSORIES | ACCESSOIRES POUR GOUTTIÈRE DE VIDANGE/SOL

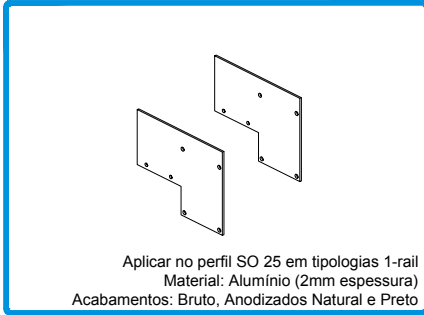

Aplicar no perfil SO 25 em tipologias 1-rail
Material: Alumínio (2mm espessura)
Acabamentos: Bruto, Anodizados Natural e Preto

212245 CONJUNTO TOPOS
CALEIRA/SOLEIRA OS-D 1-RAIL

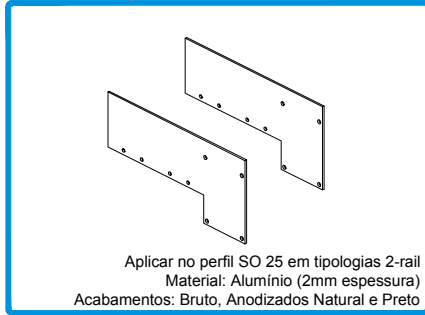

Aplicar no perfil SO 25 em tipologias 2-rail
Material: Alumínio (2mm espessura)
Acabamentos: Bruto, Anodizados Natural e Preto

212246 CONJUNTO TOPOS
CALEIRA/SOLEIRA OS-D 2-RAIL

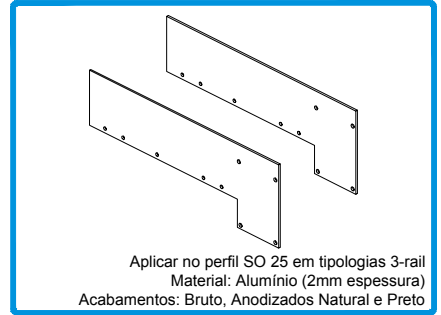

Aplicar no perfil SO 25 em tipologias 3-rail
Material: Alumínio (2mm espessura)
Acabamentos: Bruto, Anodizados Natural e Preto

212247 CONJUNTO TOPOS
CALEIRA/SOLEIRA OS-D 3-RAIL

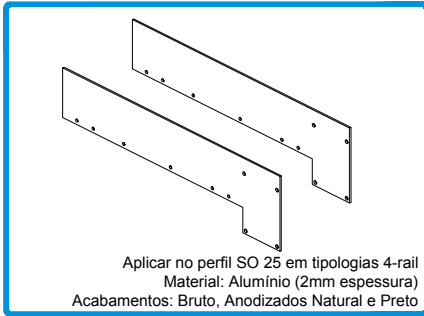

Aplicar no perfil SO 25 em tipologias 4-rail
Material: Alumínio (2mm espessura)
Acabamentos: Bruto, Anodizados Natural e Preto

212251 CONJUNTO TOPOS
CALEIRA/SOLEIRA OS-D 4-RAIL

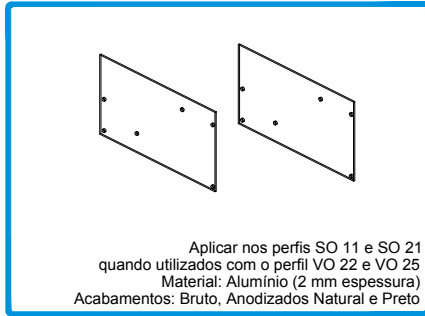

Aplicar nos perfis SO 11 e SO 21
quando utilizados com o perfil VO 22 e VO 25
Material: Alumínio (2 mm espessura)
Acabamentos: Bruto, Anodizados Natural e Preto

212285 CONJ. TOPOS P/ VO 22

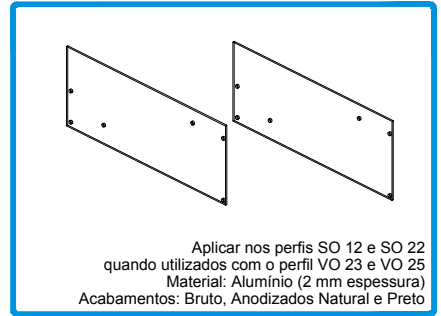

Aplicar nos perfis SO 12 e SO 22
quando utilizados com o perfil VO 23 e VO 25
Material: Alumínio (2 mm espessura)
Acabamentos: Bruto, Anodizados Natural e Preto

212287 CONJ. TOPOS P/ VO 23

SISTEMAS DE FECHO
LOCKING SYSTEMS | SYST MES DE FERMETURE

H (altura da folha)	FECHADURA
2050* - 2300 mm	1850mm
2301 - 2700 mm	2100mm
2701 - 6000 mm	2500mm

* Para uma folha com altura (H) inferior a 2050mm, dever  ser usada uma fechadura de 1 ponto.

Testa incluída

- 201053** FECHADURA OS 1850mm
- 201054** FECHADURA OS 2100mm
- 201055** FECHADURA OS 2500mm

Inclui 5 chaves
Acabamentos: Prata e Preto

207436 CILINDRO ALTA SEGURANA 30/30

Para o perfil SO 03
Cilindro com dupla embraiagem | Inclui 5 chaves
Acabamentos: Prata e Preto

207447 CILINDRO ALTA SEGURANA 35/35

N o utilizar em v os com aro fixo embutido
Inclui 5 chaves
Acabamentos: Prata e Preto

207437 CILINDRO ALTA SEGURANA 30B/30

N o utilizar em v os com aro fixo embutido
Para o perfil SO 03
Cilindro com bot o e dupla embraiagem | Inclui 5 chaves
Acabamentos: Prata e Preto

207448 CILINDRO ALTA SEGURANA 35B/35

Testa incluída

201202 FECHADURA OS MONOPONTO

Para aplicar nos perfis SO 11, 12, 13, 14 e 15
Material: PA6+SEBS | Cor: Preto

213220 AMORTECEDOR OS N 3

62 23 5.3

Acabamento: Bruto, Anodizados e Lacados

220196 ESPELHO ALUM NIO 23MM P/ SEGREDO

Material: Inox | Acabamento: Inox Escovado

280037 TESTA FECHADURA OS-D N 2

Material: ABS | Acabamento: Preto

203306 COPO P/ TESTA FECHADURA OS-D N 2

Material: Inox | Acabamento: Escovado

280000 TESTA OS-DOUBLE P/ FECHO OS N 2

Material: Inox | Acabamento: Escovado

228167 MOLLA P/ RETENAO FECHO OS N 2

Fecho ambidestro
Material: Alum nio, Inox e Poliamida
Acabamento: Anodizado e Lacado

201089 FECHO LATERAL OS N 4

Material: Nylon | Acabamento: Preto

215037 PEA AJUSTE P/ FECHO LAT. OS N 4

SISTEMAS DE FECHO
LOCKING SYSTEMS | SYSTÈMES DE FERMETURE

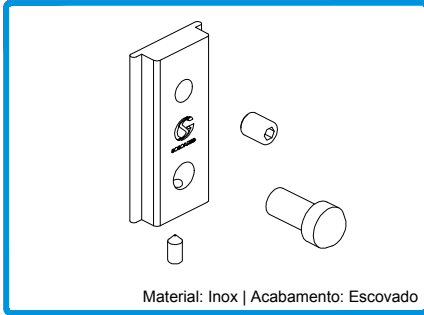

202323 CONTRA-FECHO OS INOX C/ AFINAÇÃO Nº2
Material: Inox | Acabamento: Escovado

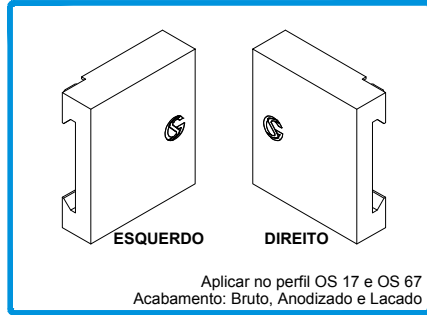

201084 FECHO CENTRAL OS Nº5 ESQ
201085 FECHO CENTRAL OS Nº5 DIR
Aplicar no perfil OS 17 e OS 67
Acabamento: Bruto, Anodizado e Lacado



203305 COPO P/ FECHO CENTRAL OS
Para aplicar com o Fecho Central OS Nº3 (opcional)
Material: Carbono | Acabamento: Preto

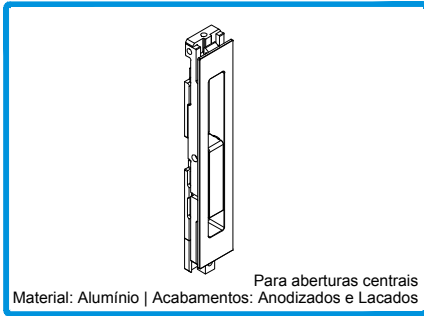

201097 FECHO DE EMBUTIR OS MONODIR.
Para aberturas centrais
Material: Alumínio | Acabamentos: Anodizados e Lacados

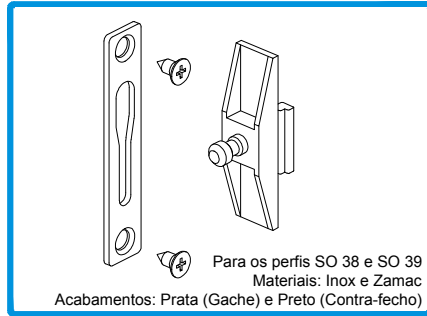

212000 CONJ. FECHO SO38/SO39
Para os perfis SO 38 e SO 39
Materiais: Inox e Zamac
Acabamentos: Prata (Gache) e Preto (Contra-fecho)

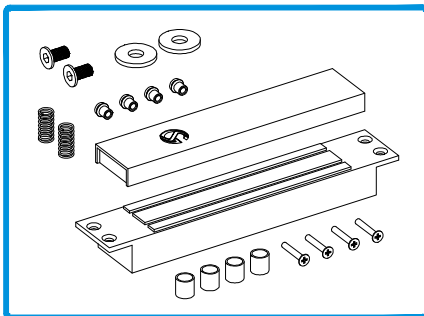

223256 KIT FECHO MAGNÉTICO OS DOUBLE

- 1 UN. → Hfolha | Hsash ≤ 1500 mm
- 2 UN. → Hfolha | Hsash > 1500 e | and ≤ 2500 mm
- 3 UN. → Hfolha | Hsash > 2500 e | and ≤ 4000 mm

FONTES DE ALIMENTAÇÃO
POWER SUPPLIES | SOURCES D'ALIMENTATION

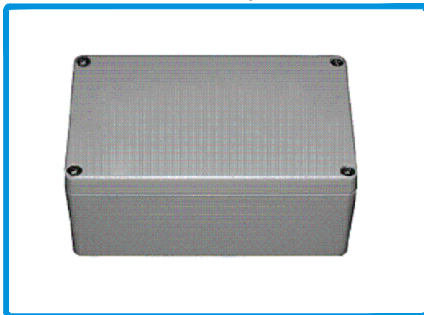

299070 UN. ALIMENTAÇÃO 12V C/ BATERIA SE

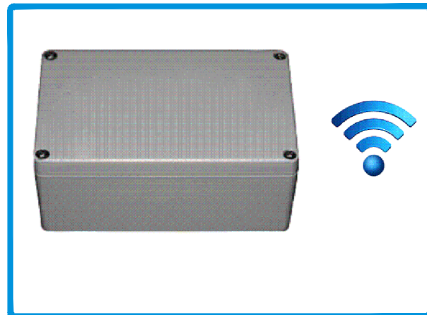

299071 UN. ALIMENTAÇÃO 12V C/ BATERIA SE (RC)

MOTORES
MOTORS | MOTEURS



Peso máx. 800Kg
223997 - Curso máx. 2500mm
223986 - Curso máx. 5500mm
223993 - Curso máx. 8000mm

223997 KIT BASE MOTOR TIPO N2 ATÉ 2500
223986 KIT BASE MOTOR TIPO N2 ATÉ 5500
223993 KIT BASE MOTOR TIPO N2 ATÉ 8000



Peso máx. 1200Kg
223994 - Curso máx. 6000mm
223995 - Curso máx. 12000mm

223994 KIT BASE MOT. TIPO N3 ATÉ 6000
223995 KIT BASE MOT. TIPO N3 ATÉ 12000



Peso máx. 800Kg
Curso máx. 5000mm

223985 KIT BASE MOTOR TIPO N3B iii)
ATÉ 5000 CURSO



Peso máx. 2500Kg
223984 - Curso máx. 6000mm
223996 - Curso máx. 12000mm

223984 KIT BASE MOTOR TIPO N4 ATÉ 6000
223996 KIT BASE MOTOR TIPO N4 ATÉ 12000



299613 CONVERTOR MOTOR N2
299614 CONVERTOR MOTOR N3

COMANDOS E BOTÕES
CONTROLLERS AND BUTTONS | COMMANDES ET BOUTONS



214255 COMANDO MURAL COM ESPELHO
S/ FIOS

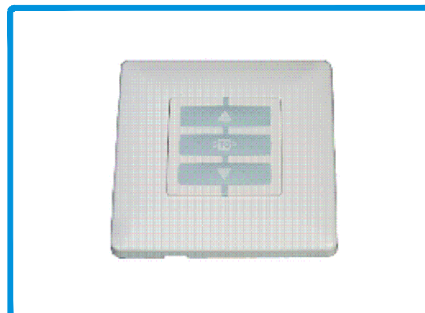

214304 COMANDO MURAL 001G PAREDE
3 VIAS

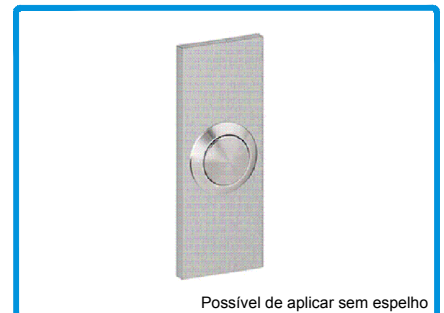

Possível de aplicar sem espelho

299090 BOTÃO DE ABERTURA INOX



299087 BOTÃO DE ABERTURA OCULTO
C/ LED



299989 SELECTOR DE CHAVE SALIENTE
C/ FIOS



299987 DIGIKEY EDSW S/ FIOS

COMANDOS E BOTÕES
CONTROLLERS AND BUTTONS | COMMANDES ET BOUTONS



299902 DIGIKEY EDS C/ FIOS



299903 LEITOR DE PROXIMIDADE Inclui 3 cartões



214269 COMANDO DIST. RF P1

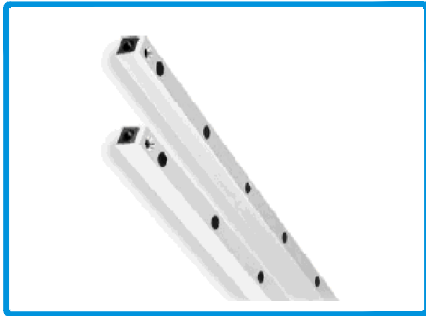

223084 KIT FOTOCÉLULAS CORTINA 900MM

223983 KIT FOTOCÉLULAS CORTINA 1480MM



223085 KIT FOTOCÉLULAS SLIM

ACESSÓRIOS PARA MOSQUITEIRA
RESEQUIVA TOUINETE ACCESSORIES FOR MOUTSIQUAIRE

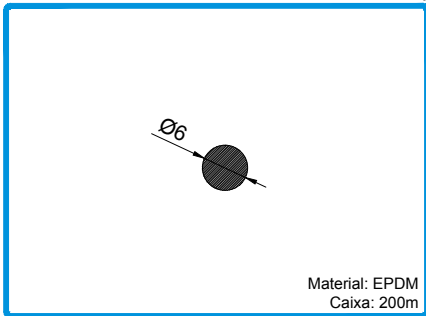

208310 JUNTA MOSQUITEIRO 1027 Pr.
Material: EPDM
Caixa: 200m

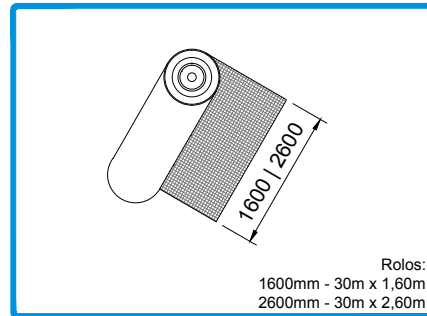

229105 REDE MOSQ. FIBRA 1600mm (Cinza)
229106 REDE MOSQ. FIBRA 2600mm (Cinza)
Rolos:
1600mm - 30m x 1,60m
2600mm - 30m x 2,60m

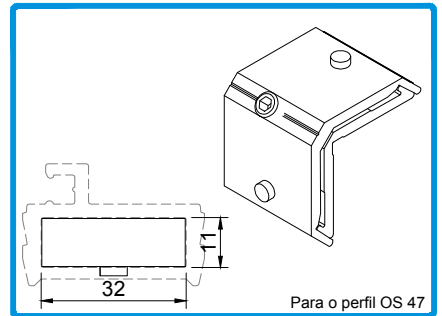

204149 ESQUADRO 18-3112-C
Para o perfil OS 47

ACESSÓRIOS RENOVIATIO
RENOVIATIO ACCESSORIES | ACCESSOIRES RENOVIATIO

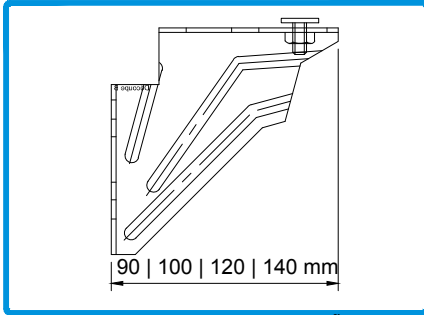

230309 SUPORTE FIXAÇÃO 90mm
230014 SUPORTE FIXAÇÃO 100mm
230019 SUPORTE FIXAÇÃO 120mm
230308 SUPORTE FIXAÇÃO 140mm

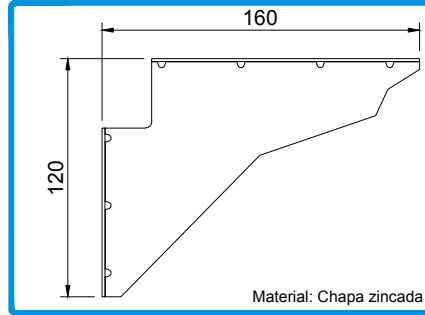

230316 SUPORTE FIXAÇÃO 160MM
Material: Chapa zincada

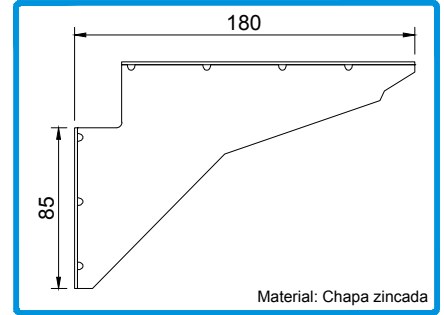

230317 SUPORTE FIXAÇÃO 180MM
Material: Chapa zincada

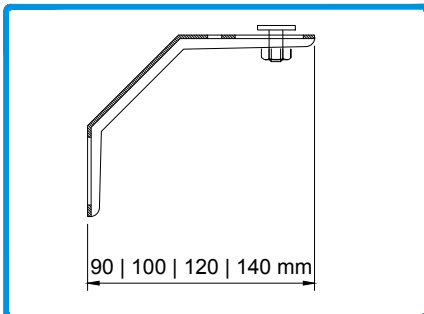

213257 ÂNGULO FIXAÇÃO 90mm
213239 ÂNGULO FIXAÇÃO 100mm
213240 ÂNGULO FIXAÇÃO 120mm
213256 ÂNGULO FIXAÇÃO 140mm

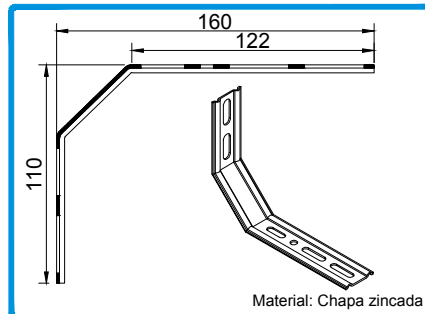

213235 ÂNGULO FIXAÇÃO 160MM
Material: Chapa zincada

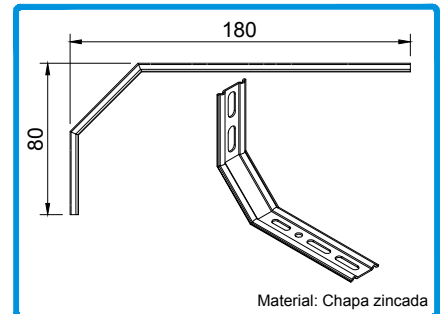

213311 ÂNGULO FIXAÇÃO 180MM
Material: Chapa zincada

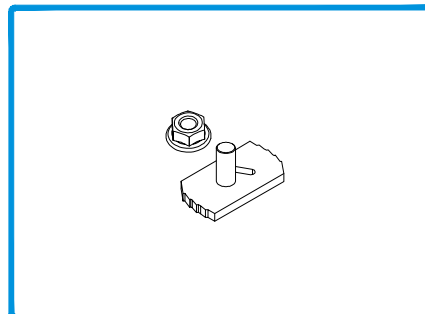

207220 PRESILHA M6x37mm

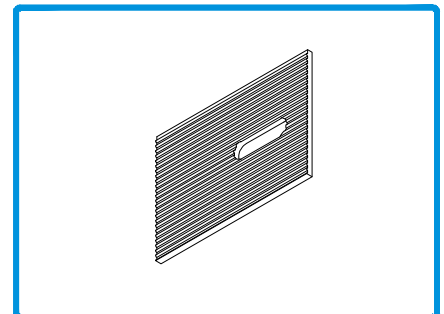

218116 CALÇO SEPARADOR 50x70mm

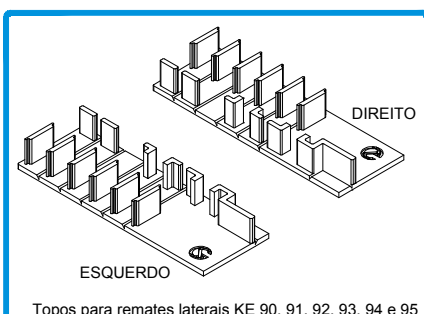

Topos para remates laterais KE 90, 91, 92, 93, 94 e 95
212223 CONJUNTO TOPOS INFERIORES RENOVIATIO

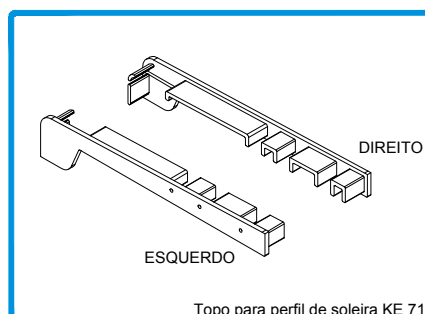

Topo para perfil de soleira KE 71
212221 CONJUNTO TAPA TOPOS KE 71

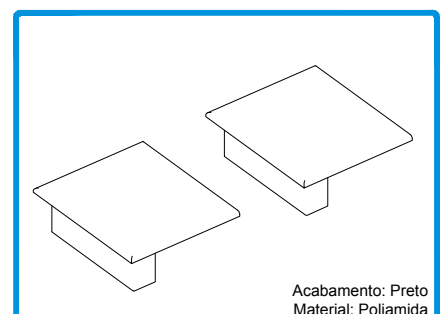

Acabamento: Preto
Material: Poliamida
212173 CONJ. TOPOS KE51-KE52

DIVERSOS
DIVERS | DIVERS

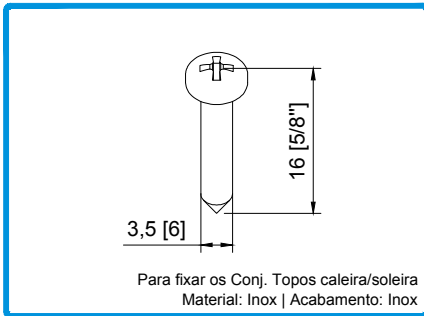

290729 PARAF PKI PH 5/8x6 CQ

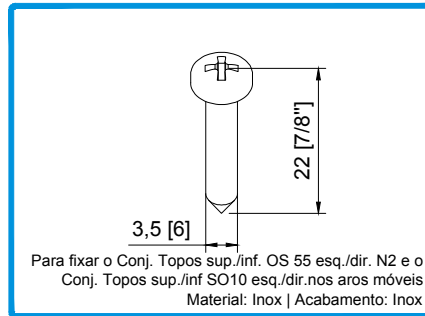

290031 PARAF. DIN7981 PH 3,5x22 INOX A2

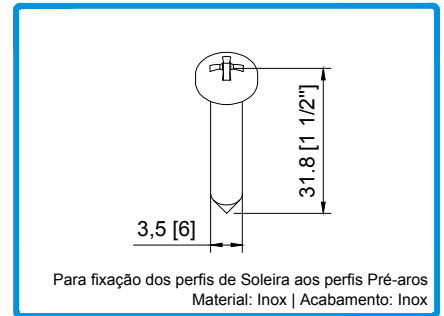

290082 PARAF DIN7981 PH 3,5x38 A2

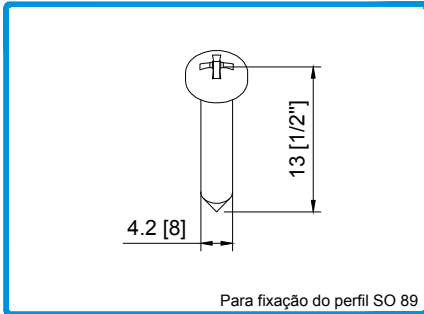

290111 PARAFUSO CQ 4,2x13 INOX A2

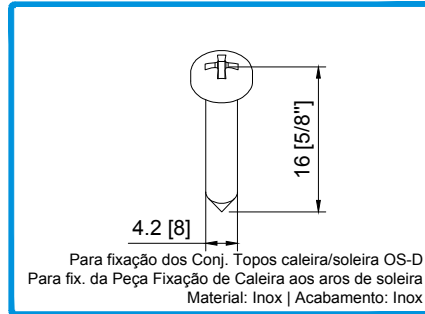

290088 PARAF. DIN7981 PH 4,2x16 INOX A2

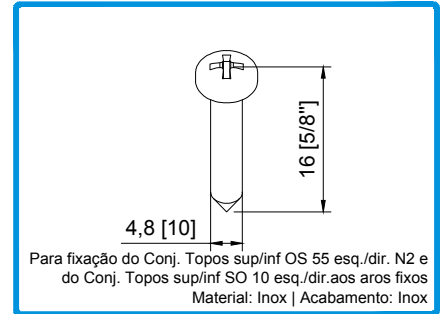

290064 PARAF. DIN7981 PH 4,8x16 INOX A2

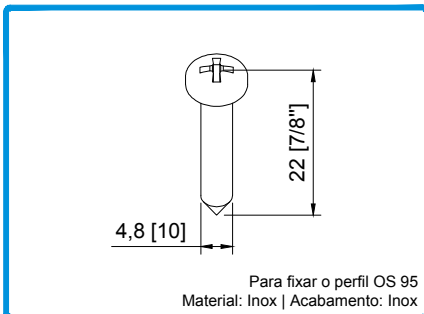

290020 PARAFUSO PAR 006 7/8x10 CQ

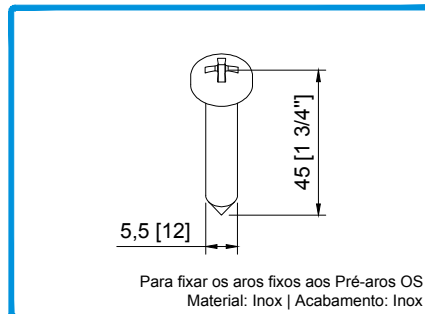

290264 PARAF. PAR 005 PK 1 3/4X12 CQ

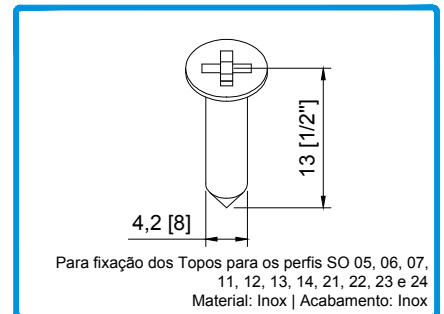

290061 PARAF. DIN7982 PH 4,2x13 INOX A2

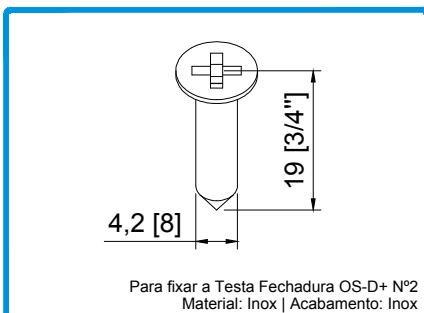

290105 PARAF. INOX A2 DIN7982 8X3/4 RB

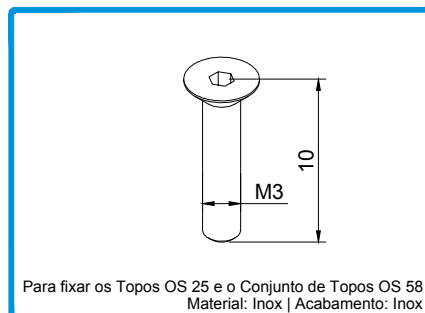

290016 PARAFUSO FIXAÇÃO DE TOPOS

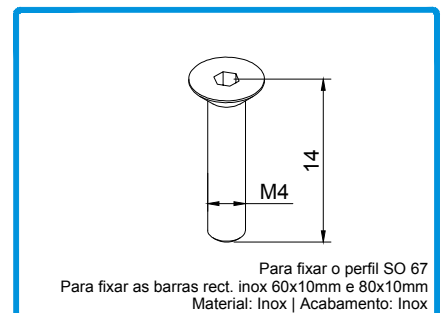

290473 PARAFUSO DIN7991 M4X14 INOX A2

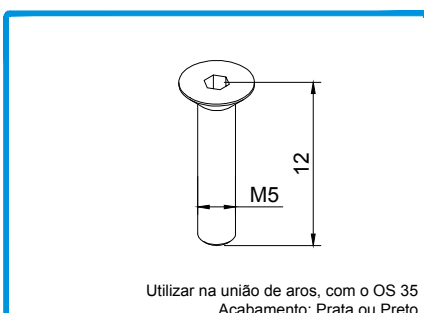

290059 PARAFUSO DIN7991 M5x12 INOX A2

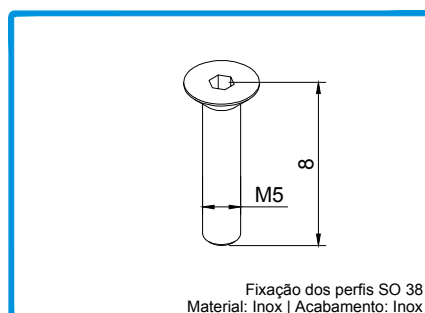

290099 PARAF. DIN7991 M5X8 INOX A2

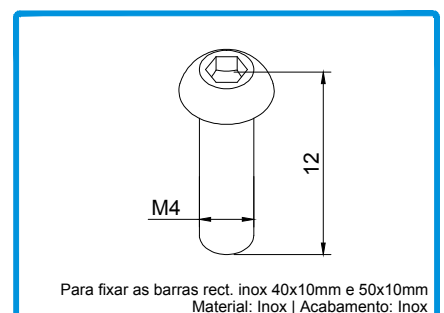

290112 PARAFUSO ISO7380 M4X12 INOX A2

DIVERSOS
DIVERS | DIVERS

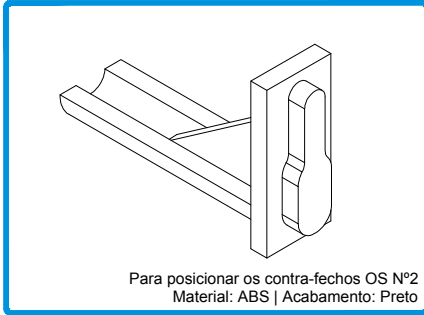

Para posicionar os contra-fechos OS N°2
Material: ABS | Acabamento: Preto

211609 GABARITO P/ CONTRA-FECHOS OS N°2

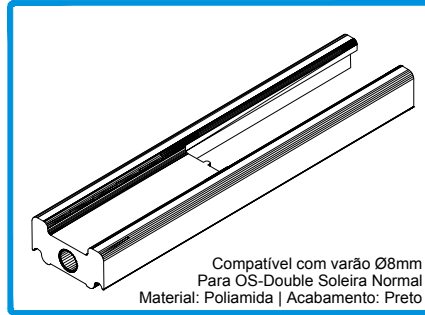

Compatível com varão Ø8mm
Para OS-Double Soleira Normal
Material: Poliamida | Acabamento: Preto

211214 PEÇA P/ APL. CARRINHOS OS V2

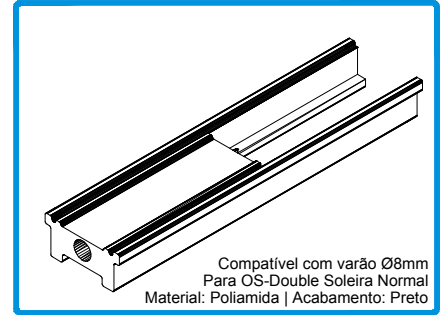

Compatível com varão Ø8mm
Para OS-Double Soleira Normal
Material: Poliamida | Acabamento: Preto

211215 PEÇA P/ APL. CARRINHOS OS V2 SOL. OC.



Limpeza de alumínio lacado ou anodizado
Para preparação das superfícies a serem unidas e limpeza final

208704 PRODUTO LIMPEZA DE ALUMÍNIO (1L) Transparente



Junta de vedação elástica, resistente aos U.V.
Impede a corrosão de penetrar pelas zonas cortadas.

208019 SELA JUNTAS 150gr. (Cinza)



Resistente a raios UV
Rolo: 2m
Material: Junta Adesiva Composta | Acabamento: Branco

299112 MEMBRANA SELAGEM 50MM (2M)

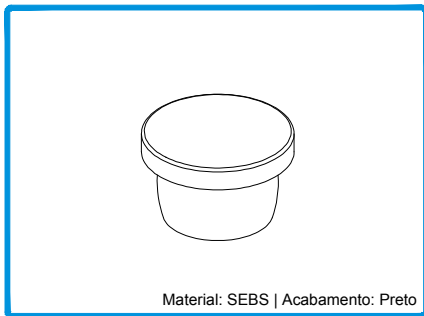

Material: SEBS | Acabamento: Preto

210604 TAPA FUROS P/ AMORTECEDOR OS N.3

FERRAMENTAS
TOOLS | OUTILS

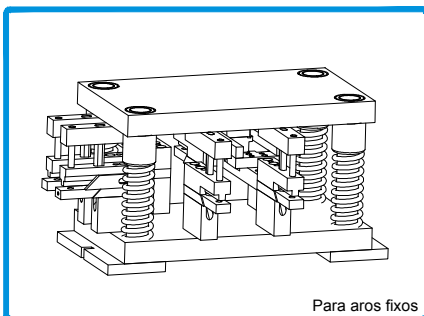

Para aros fixos

408175 CORTANTE ESQUADROS OS N° 2

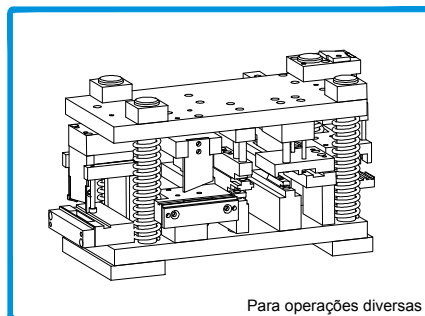

Para operações diversas

408168 CORTANTE OS

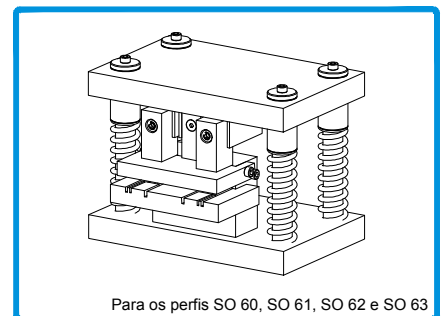

Para os perfis SO 60, SO 61, SO 62 e SO 63

408024 CORTANTE CAPAS OS-D



Casa de la Brisa | Castellón | Fran Silvestre, Arq | Fotografia Diego Opazo

IV

TIPOLOGIAS E MAPA DE QUANTIDADES - OS-D⁺ TRADICIONAL TYPOLOGIES AND QUANTITY MAPS - OS-D⁺ CLASSIC TYPOLOGIES ET CARTES DE QUANTITÉS - OS-D⁺ CLASSIQUE

Tipologias para vãos fixos Fixed frames typologies Typologies pour cadres fixes	IV.1
Tipologias standard Standard typologies Typologies standard	IV.2
Tipologias de embutir Pocket typologies Typologies à galandage	IV.3
Tipologias de fechadura Locker typologies Typologies avec serrure	IV.4
Outras tipologias Other typologies Autres typologies	IV.5

TABELA DE ENCHIMENTOS - SOLUÇÃO DE VÃO FIXO SIMPLES
FILLING TABLE - SIMPLE FIXED FRAME SOLUTION
TABLE DE VITRAGE - SOLUTION CADRE FIXE SIMPLES

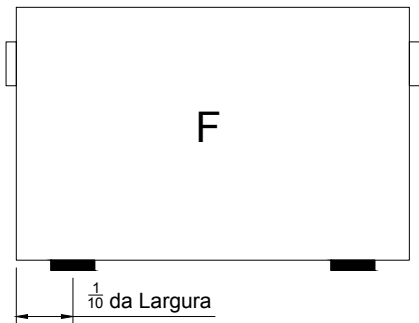

CALÇO P/VIDRO 79x40x5
GLAZING SHIM | CALE DE VITRAGE

- CALÇO DE APOIO**
SUPPORT SHIM | CALE D'ASSISE
- CALÇO DE SEGURANÇA***
SAFETY SUPPORT | CALE DE SÉCURITÉ

* Opção
OPTION | OPTION

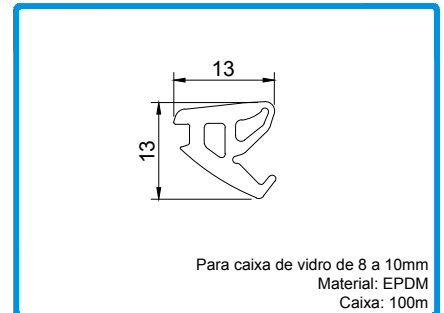

Para caixa de vidro de 8 a 10mm
Material: EPDM
Caixa: 100m

208912 JUNTA DE CUNHA RECORTADA 4193
GASKET | JOINT

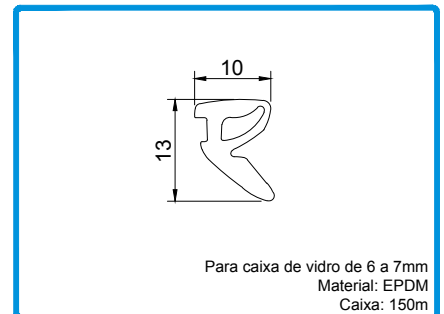

Para caixa de vidro de 6 a 7mm
Material: EPDM
Caixa: 150m

208913 JUNTA DE CUNHA RECORTADA 4194
GASKET | JOINT

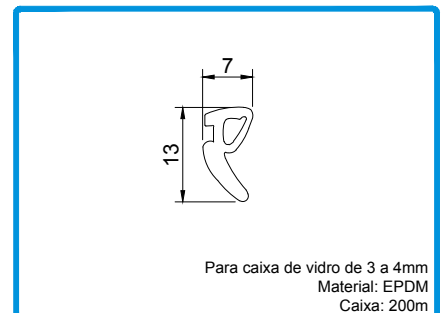

Para caixa de vidro de 3 a 4mm
Material: EPDM
Caixa: 200m

208914 JUNTA DE CUNHA RECORTADA 4195
GASKET | JOINT

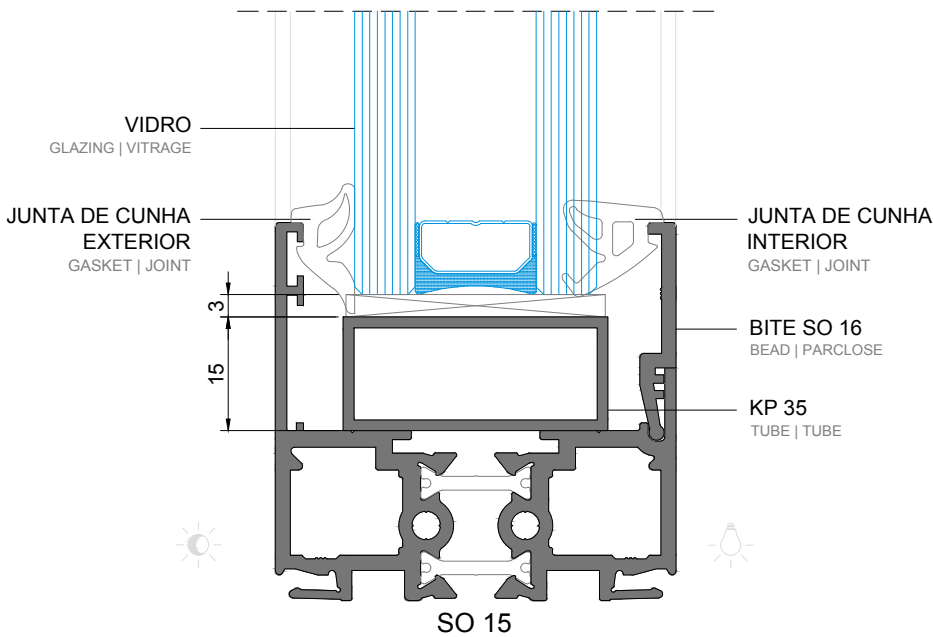

Para soluções de aro fixo com o perfil SO 15

218109 CALÇO P/VIDRO 79x40x3
GLASS SUPPORT 79x40x3
CALES À VIDRAGE 79x40x3

VEDANTE EXTERIOR OUTER GASKET JOINT EXTÉRIEUR	ESPESSURA DO VIDRO GLASS THICKNESS ÉPAISSEUR DU VERRE	VEDANTE INTERIOR INNER GASKET JOINT INTÉRIEUR	BITES GLAZING BEADS PARCLOSES
4193	30	4193	SO 16
4194	32	4193	SO 16
4194	34	4194	SO 16
4195	36	4194	SO 16
4195	38	4195	SO 16

TABELA DE ENCHIMENTOS - VÃO FIXO SOLUÇÃO OS-D⁺ 32mm

FILLING TABLE - OS-D⁺ 32mm FIXED FRAME SOLUTION

TABLE DE VITRAGE - SOLUTION OS-D⁺ 32mm CADRE FIXE

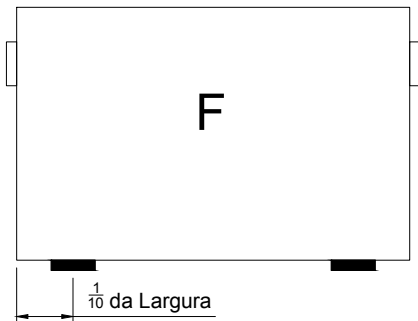

CALÇO FIXO OS-DOUBLE
OS-DOUBLE FIXED SHIM | CALE FIXE OS-DOUBLE

■ CALÇO DE APOIO
GLASS SUPPORT | CALE DE VITRAGE

□ CALÇO DE SEGURANÇA*
GLASS SUPPORT | CALE DE VITRAGE

* Opção
OPTION | OPTION

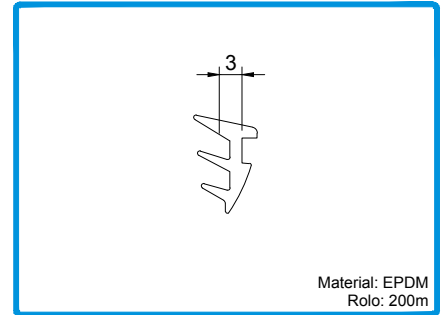

208199

JUNTA DE CUNHA 2073
GASKET | JOINT

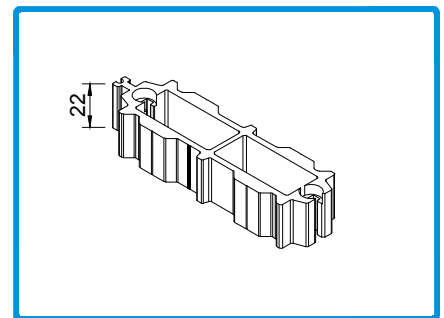

218134

CALÇO FIXO OS-DOUBLE
OS-DOUBLE FIXED SHIM
CALE FIXE OS-DOUBLE

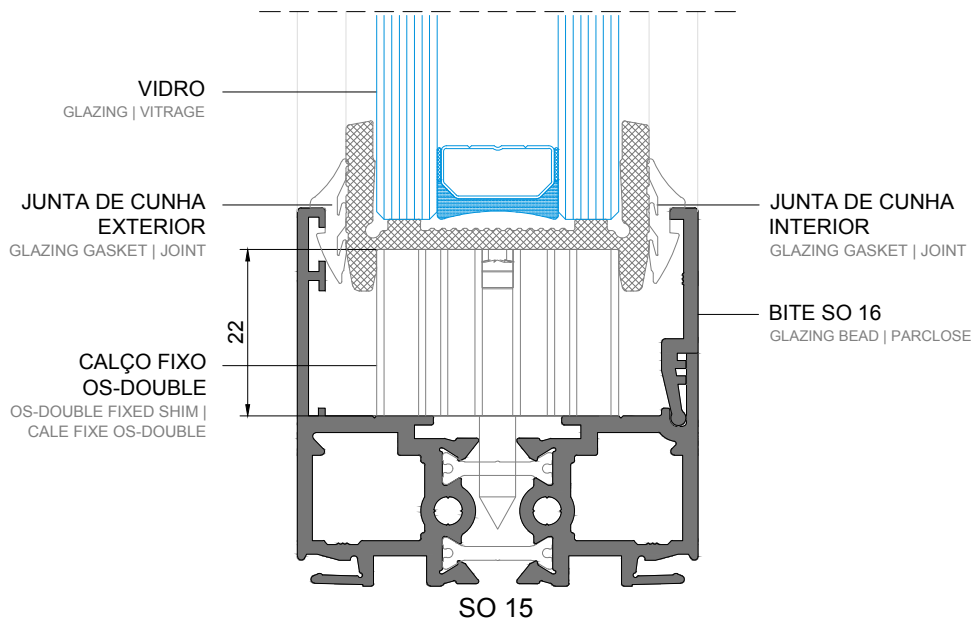

VEDANTE EXTERIOR OUTER GASKET JOINT EXTERIEUR	ESPESSURA DO VIDRO GLASS THICKNESS ÉPAISSEUR DU VERRE	VEDANTE INTERIOR INNER GASKET JOINT INTERIEUR	BITES GLAZING BEADS PARCLOSES
2073	32	2073	SO 16

FOLHA FIXA COM 1 VIDRO - SOLUÇÃO DE VÃO FIXO SIMPLES
FIXED FRAME WITH 1 GLASS - SIMPLE FIXED FRAME SOLUTION
CADRE FIXE AVEC 1 VERRE - SOLUTION CADRE FIXE SIMPLES

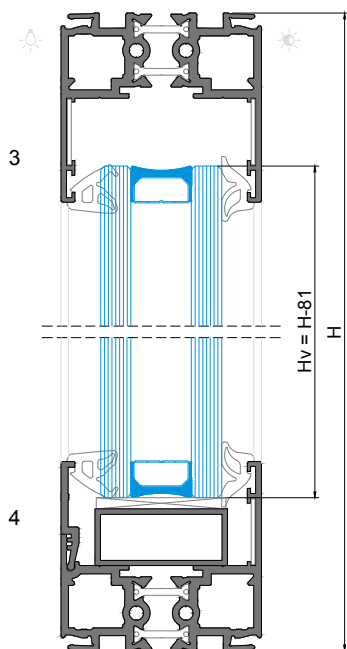
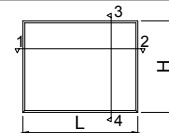

PERFIS PROFILES PROFILÉS					
CÓDIGO CODE	DESIGNAÇÃO DESIGNATION / NOMINATION	CORTE HORIZ. HORIZONTAL DETAIL DÉTAIL HORIZONTAL	CORTE VERT. VERTICAL DETAIL DÉTAIL VERTICALE	QUANT. QUANTITY	CORTE CUT
SO 14	ARO FIXO FIXED FRAME DORMANT	L	-	1	
SO 15	ARO FIXO FIXED FRAME DORMANT	L	H	1+2	
SO 16	BITE GLAZING BEAD PARCLOSE	L-62	H-100	2+2	
KP 35	TUBO TUBE TUBE		VARIÁVEL VARIABLE VARIABLE		

ACESSÓRIOS ACCESSORIES ACCESSOIRES		
CÓDIGO CODE	DESIGNAÇÃO DESIGNATION / NOMINATION	QUANTIDADE QUANTITY / QUANTITÉ
205173	ESQUADRO 18-1310-C BLOCKING BRACKET ÉQUERRE	8
218109	CALÇO P/VIDRO 79x40x3 GLASS SUPPORT CALE DE VITRAGE	DIVERSOS DIVERSES DIVERS
213018	CANTO DE ALINHAMENTO OS N.2 REINFORCING CORNER CLEAT ÉQUERRE RENFORCEMENT	4

VEDANTES SEALENTS JOINTS		
CÓDIGO CODE	DESIGNAÇÃO DESIGNATION / NOMINATION	QUANTIDADE QUANTITY / QUANTITÉ
OPÇÃO*	JUNTA DE CUNHA INTERIOR GASKET JOINT	2L + 2H
OPÇÃO*	JUNTA DE CUNHA EXTERIOR GASKET JOINT	2L + 2H

*Consultar tabela de enchimentos | Consult table of glazing | Consulter le tableau des vitrage

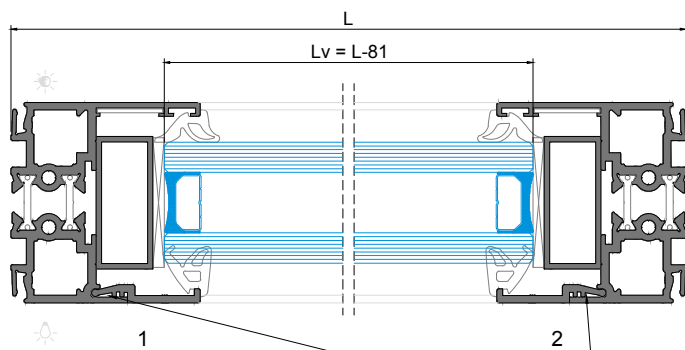

Aplicar silicone pontualmente
Apply silicone punctually
Appliquer le silicone ponctuellement

FOLHA FIXA COM 2 VIDROS - SOLUÇÃO DE VÃO FIXO SIMPLES
FIXED FRAME WITH 2 GLASSES - SIMPLE FIXED FRAME SOLUTION
CADRE FIXE AVEC 2 VERRE - SOLUTION CADRE FIXE SIMPLES

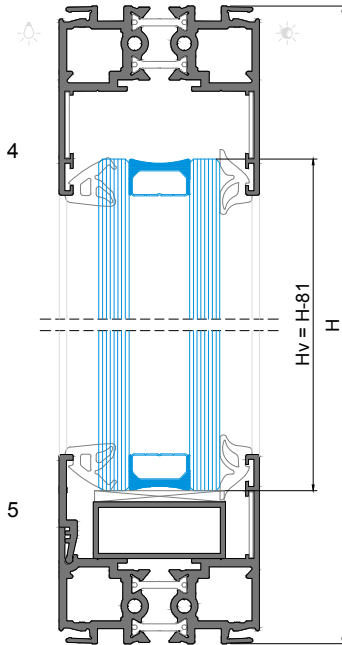
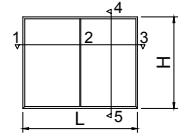

PERFIS PROFILES PROFILÉS					
CÓDIGO CODE	DESIGNAÇÃO DESIGNATION NOMINATION	CORTE HORIZ. HORIZONTAL DETAIL	CORTE VERT. VERTICAL DETAIL	QUANT. QUANTITY	CORTE CUT
SO 14	ARO FIXO FIXED FRAME DORMANT	L	-	1	
SO 15	ARO FIXO FIXED FRAME DORMANT	L	H	1+2	
SO 16	BITE GLAZING BEAD PARCLOSE	L-62	H-100	2+2	
KP 35	TUBO TUBE TUBE	VARIÁVEL VARIABLE VARIABLE			

ACESSÓRIOS ACCESSORIES ACCESSOIRES		
CÓDIGO CODE	DESIGNAÇÃO DESIGNATION NOMINATION	QUANTIDADE QUANTITY QUANTITE
205173	ESQUADRO 18-1310-C BLOCKING BRACKET ÉQUERRE	8
218112	CALÇO P/VIDRO 79x40x5 GLASS SUPPORT CALE DE VITRAGE	DIVERSOS DIVERSES DIVERS
213018	CANTO DE ALINHAMENTO OS N.2 REINFORCING CORNER CLEAT ÉQUERRE RENFORCEMENT	4

VEDANTES SEALENTS JOINTS		
CÓDIGO CODE	DESIGNAÇÃO DESIGNATION NOMINATION	QUANTIDADE QUANTITY QUANTITE
OPÇÃO*	JUNTA DE CUNHA INTERIOR GASKET JOINT	2L + 2H
OPÇÃO*	JUNTA DE CUNHA EXTERIOR GASKET JOINT	2L + 2H

*Consultar tabela de enchimentos | Consult table of glazing | Consulter le tableau des vitrage

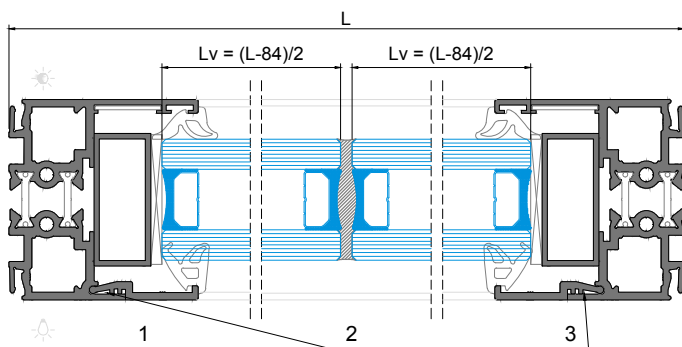

Aplicar silicone pontualmente
Apply silicone punctually
Appliquer le silicone ponctuellement

FOLHA FIXA CANTO 90° - SOLUÇÃO DE VÃO FIXO SIMPLES
90° ANGLE FIXED FRAME - SIMPLE FIXED FRAME SOLUTION
CADRE FIXE ANGLE 90° - SOLUTION CADRE FIXE SIMPLES

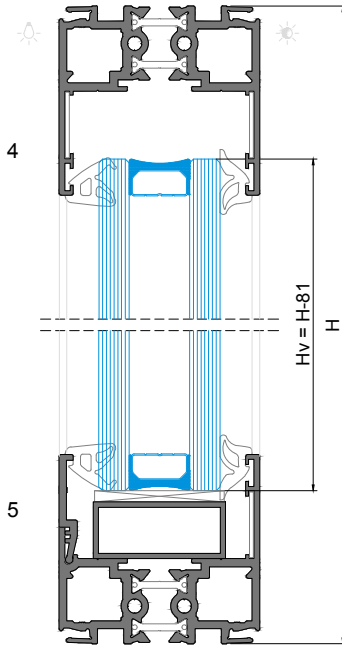
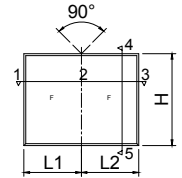

PERFIS PROFILES PROFILÉS					
CÓDIGO CODE	DESIGNAÇÃO DESIGNATION / NOMINATION	CORTE HORIZ. HORIZONTAL DETAIL	CORTE VERT. VERTICAL DETAIL	QUANT. QUANTITY	CORTE CUT
SO 14	ARO FIXO FIXED FRAME DORMANT	L1 L2	-	1	
SO 15	ARO FIXO FIXED FRAME DORMANT	L1 L2	H	1 + 2	
SO 16	BITE GLAZING BEAD PARCLOSE	L1-84 L2-84	H-100	2 + 2	
KP 35	TUBO TUBE TUBE	VARIÁVEL VARIABLE VARIABLE			

ACESSÓRIOS ACCESSORIES ACCESSOIRES		
CÓDIGO CODE	DESIGNAÇÃO DESIGNATION / NOMINATION	QUANTIDADE QUANTITY / QUANTITE
205173	ESQUADRO 18-1310-C BLOCKING BRACKET ÉQUERRE	8
218112	CALÇO P/VIDRO 79x40x5 GLASS SUPPORT CALE DE VITRAGE	DIVERSOS DIVERSES DIVERS
213018	CANTO DE ALINHAMENTO OS N.2 REINFORCING CORNER CLEAT ÉQUERRE REINFORCEMENT	4

VEDANTES SEALENTS JOINTS		
CÓDIGO CODE	DESIGNAÇÃO DESIGNATION / NOMINATION	QUANTIDADE QUANTITY / QUANTITE
OPÇÃO*	JUNTA DE CUNHA INTERIOR GASKET JOINT	2L1 + 2L2 + 2H
OPÇÃO*	JUNTA DE CUNHA EXTERIOR GASKET JOINT	2L1 + 2L2 + 2H

*Consultar tabela de enchimentos | Consult table of glazing | Consulter le tableau des vitrage

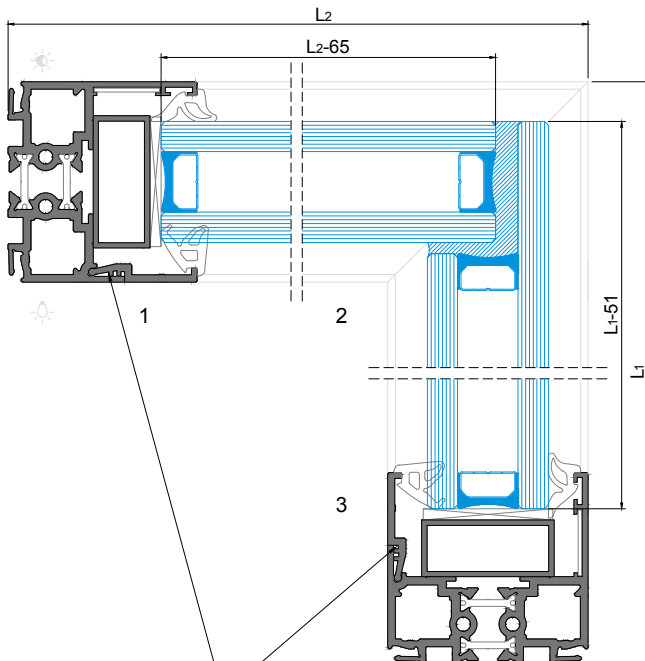

Aplicar silicone pontualmente
Apply silicone punctually
Appliquer le silicone ponctuellement

FOLHA FIXA COM 1 VIDRO - SOLUÇÃO OS-D⁺ [32mm]
FIXED FRAME WITH 1 GLASS - OS-D⁺ [32mm] SOLUTION
CADRE FIXE AVEC 1 VERRE - SOLUTION OS-D⁺ [32mm]

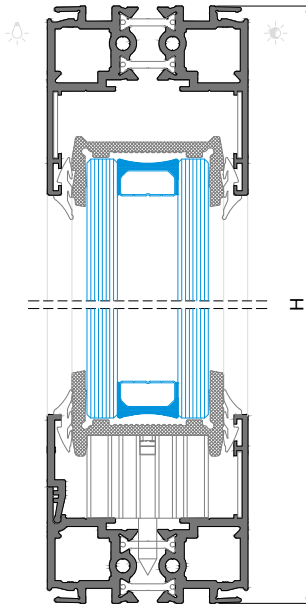
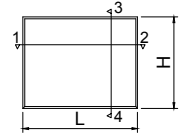

PERFIS PROFILES PROFILÉS					
CÓDIGO CODE	DESIGNAÇÃO DESIGNATION NOMINATION	CORTE HORIZ. HORIZONTAL DETAIL	CORTE VERT. VERTICAL DETAIL	QUANT. QUANTITY	CORTE CUT
SO 14	ARO FIXO FIXED FRAME DORMANT	L	-	1	
SO 15	ARO FIXO FIXED FRAME DORMANT	L	H	1+2	
SO 16	BITE GLAZING BEAD PARCLOSE	L-62	H-100	2+2	

ACESSÓRIOS ACCESSORIES ACCESSOIRES		
CÓDIGO CODE	DESIGNAÇÃO DESIGNATION NOMINATION	QUANTIDADE QUANTITY QUANTITE
205173	ESQUADRO 18-1310-C BLOCKING BRACKET ÉQUERRE	8
213018	CANTO DE ALINHAMENTO OS N.2 REINFORCING CORNER CLEAT ÉQUERRE REINFORCEMENT	4
218134	CALÇO FIXO OS-DOUBLE FIXED SHIM CALE FIXE	2

VEDANTES SEALENTS JOINTS		
CÓDIGO CODE	DESIGNAÇÃO DESIGNATION NOMINATION	QUANTIDADE QUANTITY QUANTITE
208199	JUNTA DE CUNHA INTERIOR GASKET JOINT	2L + 2H
208199	JUNTA DE CUNHA EXTERIOR GASKET JOINT	2L + 2H

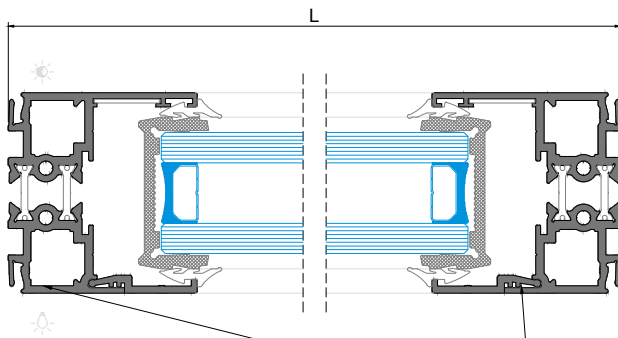

Aplicar silicone pontualmente
Apply silicone punctually
Appliquer le silicone ponctuellement

JANELA DE CORRER 2 FOLHAS - LINHA OS-Simple
2 SASHES SLIDING WINDOW - OS-Simple GLAZING LINE
FENÊTRE COULISSANT 2 VANTAOX - LIGNE OS-Simple

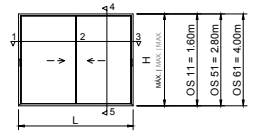

PERFIS PROFILES PROFILÉS					
CÓDIGO CODE	DESIGNAÇÃO DESIGNATION NOMINATION	CORTE HORIZ. HORIZONTAL DETAIL	CORTE VERT. VERTICAL DETAIL	QUANT. QUANTITY	CORTE CUT
SO 11	ARO FIXO FIXED FRAME DORMANT	L	H	2+2	
OS 11	ARO MÓVEL CENTRAL PROFILE PROFILÉ	-	H-118	2	
SO 66	ARO MÓVEL LATERAL MOBILE FR. OUVRANT	-	H-118	2	
SO 30	VARETA ROD PROFILE TIGE	-	VARIÁVEL VARIABLE VARIABLE	2	
OS 801	GUIA INF. INOX LOWER GUIDE GUIDE INFÉRIEUR	L-46	-	2	
OS 35	GUIA SUP. UPPER GUIDE GUIDE SUPÉRIEUR	L-46	-	2	
SO 60	CAPA COVER COUVERTURE	-	H-46	2	
OS 30	CAPA COVER COUVERTURE	(L/2)-65	-	4	
OS 95	POLIAMIDA POLYAMIDE POLYAMIDE	(L/2)-50	H-74	4+2	
SO 82	PERFIL SOLEIRA SILL PROFILE PROFILÉ DE SEUIL	CONSULTAR DEPARTAMENTO TÉCNICO CONSULT TECHNICAL DEPARTMENT CONSULTER DÉPARTEMENT TECHNIQUE			
SO 25	PERFIL CALEIRA DRAINAGE CHANNEL GOUTTIÈRE DE VIDANGE				
SO 58	TAMPA DE CALEIRA DRAINAGE CHANNEL GRID GRILLE POUR GOUTTIÈRE DE VIDANGE				
VO 11	PERFIL FIXAÇÃO TAMPA DRAINAGE (1) CHANNEL GRID FIX. PROF. PROF. FIXATION GRILLE				

(1) Peças com 400mm, aplicadas aproximadamente a cada 800mm | Pieces 400mm long, applied approximately every 800mm | Pièces de 400 mm, appliquées à environ tous les 800 mm

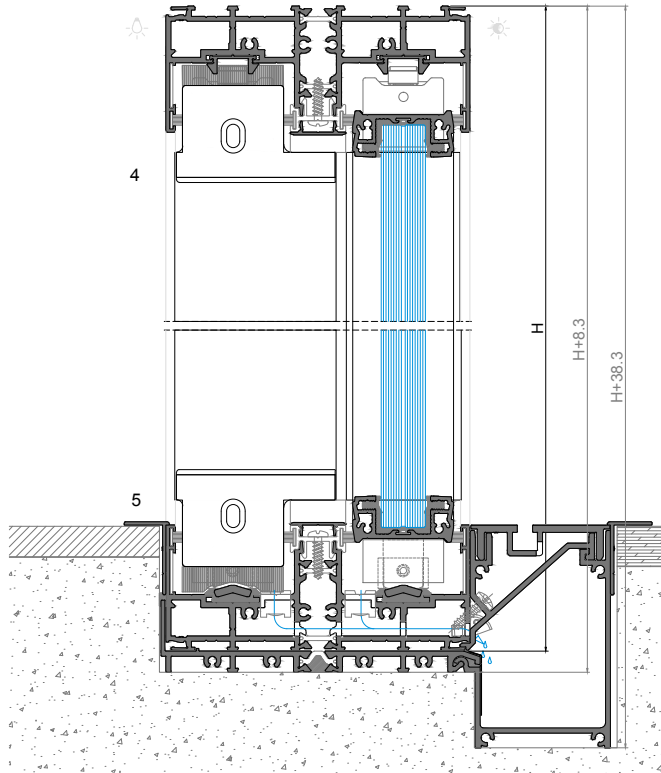

ACESSÓRIOS ACCESSORIES ACCESSOIRES		
CÓDIGO CODE	DESIGNAÇÃO DESIGNATION NOMINATION	QUANTIDADE QUANTITY QUANTITÉ
205162	CARRINHO OS Nº5 ROLLER BEARING ROULEAU	4
205161	CARRINHO-GUIA OS SUPERIOR Nº3 UPPER-GUIDE ROLLER BEARING N3 ROULEAU-GUIDE SUPÉRIEUR N3	4
205172	ESQUADRO 18-2210-D BLOCKING BRACKET ÉQUERRE	8
213018	CANTO DE ALINHAMENTO OS N.2 ANGLE ANGLE	8
202323	CONTRA-FECHO OS INOX C/ AFINAÇÃO Nº2 COUNTER-LOCK BRACKET CONTRE-FERMETURE SUPPORT	6
213220	AMORTECEDOR OS N.3 SHOCK ABSORBER AMORTISSEUR	4
201089	FECHO LATERAL OS Nº4 Nº4 LATERAL LOCK SERRURE LATÉRALE Nº4	2
280000	TESTA OS-D P/FECHO OS N.2 STRIKING PLATE GÂCHE	6
215037	PEÇA AJUSTE P/FECHO LAT OS N.4 ADJUSTMENT PIECE PIÈCE DE RÉGLAGE	8
228186	MOLA PARA RETENÇÃO DE FECHO OS OS LOCK RETAINER SPRING RESSORT DE RETENUE POUR FERMETURE OS	2
210094	TOPO CENTRAL Nº2 OS-V2 ESQUERDO CENTRAL Nº2 LEFT END-CAP EMBOUT CENTRAL Nº2 GAUCHE	2
210095	TOPO CENTRAL Nº2 OS-V2 DIREITO CENT. Nº2 RIGHT END-CAP EMBOUT CENT. Nº2 DROITE	2
210165	TOPO LATERAL SUP/INF Nº15 OS-V2 LATERAL UPPER/LOWER Nº15 OS-V2 END-CAP EMBOUT LAT SUP/INF Nº15 OS-V2	4
213273	CORTA-VENTO OS SUPERIOR UPPER CENTRAL GASKET PIÈCE D'ÉTANCHEÏTE SUPÉRIEUR	1
213274	CORTA-VENTO OS INFERIOR LOWER CENTRAL GASKET PIÈCE D'ÉTANCHEÏTE INFÉRIEUR	1
210266	GOTEIRA C/ VÁLVULA SVE FLAP VALVE CLAPET À VOLET	DIVERSOS DIVERSES DIVERS
210265	GOTEIRA C/ VÁLVULA BOLA BALL VALVE CLAPET À BILLE	DIVERSOS DIVERSES DIVERS
290020	PARAFUSO PAR 006 SCREW VIS	DIVERSOS DIVERSES DIVERS
215078	PEÇA ANTI-LEVANTAMENTO OS ANTI-LIFT ACCESSORY ANTI-LEVAGE ACCESSOIRE	2
215083	ANTI-LEVANTAMENTO GUIA INOX OS OS GUIDE ANTI-LIFT ACCESSORY ACCESSOIRE ANTI-LEVAGE POUR GUIDE INOX OS	4
215194	CHAPA BLOQUEIO PELÚCIA PILE SEAL LOCK PLATE PLAQUE DE VERROUILLAGE DE JOINT BROSSÉ	4
210510	TOPO BLOQUEIO PELÚCIA CV PILE SEAL LOCK END-CAP CV EMBOUT DE VERROUILLAGE DE JOINT BROSSÉ CV	4
212246	CONJ. TOPOS CAL/SOL OS-D 2-RAIL DRAINAGE CHANNEL/SILL OS-D 2-RAIL END-CAP KIT KIT D'EMBOUT DE GOUTTIÈRE/SEUIL OS-D 2-RAIL	1

VEDANTES SEALENTS JOINTS		
CÓDIGO CODE	DESIGNAÇÃO DESIGNATION NOMINATION	QUANTIDADE QUANTITY QUANTITÉ
208450 ou or ou	PELÚCIA 7x5.5 Cinza PILE SEAL JOINT BROSSÉ ou or ou	8L
208465	PELÚCIA 7x5.5 Preta PILE SEAL JOINT BROSSÉ	6H
208460	PELÚCIA 7x7 S-F PILE SEAL JOINT BROSSÉ	4un.
208597	PELÚCIA SRF SRF 4X8X100 2P1M PILE SEAL JOINT BROSSÉ	2H
208499	VD 2063.N	2L
208193	VD 2060	2L
208187	VD 2076 (Para vidro for glass pour verre 88.2) ou or ou	INCLUÍDA NO VIDRO INCLUDED IN GLASS INCLUS DANS LE VERRRE
208188	VD 2077 (Para vidro for glass pour verre 66.2) ou or ou	
208207	VD 2078 (Para vidro for glass pour verre 44.2)	
208186	VD 2075	

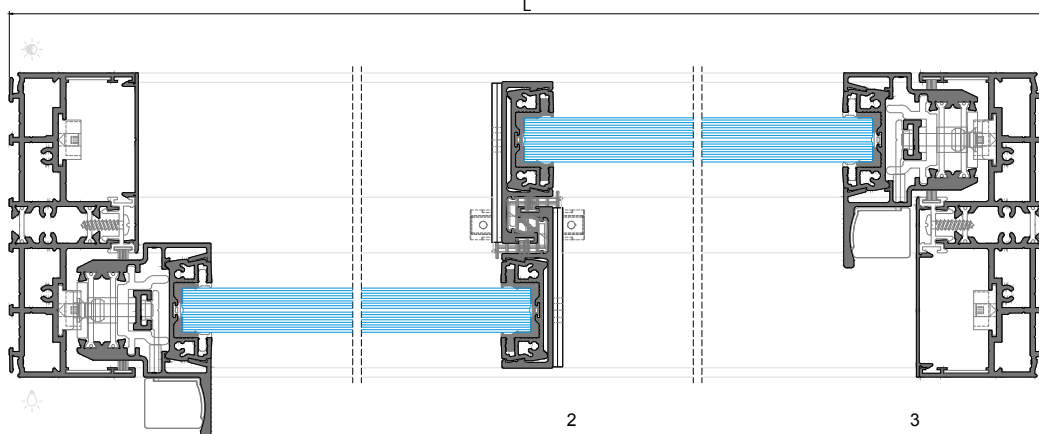

JANELA DE CORRER 2 FOLHAS COM PERFIS CENTRAIS OS 11 | OS 51 | OS 61
2 SASHES SLIDING WINDOW WITH CENTRAL PROFILES OS 11 | OS 51 | OS 61
FENÊTRE COULISSANT 2 VANTAOX AVEC PROFILÉS CENTRALES OS 11 | OS 51 | OS 61

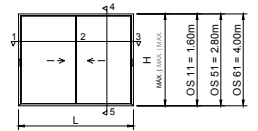

PERFIS PROFILES PROFILÉS					
CODIGO CODE	DESIGNAÇÃO DESIGNATION NOMINATION	CORTE HORIZ. HORIZONTAL DETAIL	CORTE VERT. VERTICAL DETAIL	QUANT. QUANTITY	CORTE CUT
OS 11 ou or ou	ARO FIXO FIXED FRAME DORMANT	L	H	2+2	
OS 11 ou or ou	ARO MÓVEL CENTRAL PROFILE PROFILÉ	-	H-118	2	
OS 30	VARETA ROD PROFILE TIGE	-	VARIÁVEL VARIABLE VARIABLE	2	
OS 60	TAMPA DE CANAL TRACK COVER PROFILÉ CACHE CANAL	-	H-46	2	
OS 66	ARO MÓVEL LATERAL MOBILE FR. LOUVRANT	-	H-118	2	
OS 35	GUIA SUP. UPPER GUIDE GUIDE SUPÉRIEUR	L-46	-	2	
OS 801	GUIA INF. INOX LOWER GUIDE GUIDE INFÉRIEUR	L-46	-	2	
OS 95	POLIAMIDA POLYAMIDE POLYAMIDE	(L/2)-50	H-74	4+2	
OS 30	PERFIL REMATE PROFILE PROFILÉ	(L/2)-65	-	4	
OS 82	PERFIL SOLEIRA SILL PROFILE PROFILÉ DE SEUIL	CONSULTAR DEPARTAMENTO TÉCNICO CONSULT TECHNICAL DEPARTMENT CONSULTER DÉPARTEMENT TECHNIQUE			
OS 25	PERFIL CALEIRA DRAINAGE CHANNEL GOUTTIÈRE DE VIDANGE				
OS 58	TAMPA DE CALEIRA DRAINAGE CHANNEL GRID GRILLE POUR GOUTTIÈRE DE VIDANGE				
VO 11	PERFIL FIXAÇÃO TAMPA DRAINAGE (1) CHANNEL GRID FIX. PROF. PROF. FIXATION GRILLE				

(1) Peças com 400mm, aplicadas aproximadamente a cada 800mm | Pieces 400mm long, applied approximately every 800mm | Pièces de 400 mm, appliquées à environ tous les 800 mm

ACESSÓRIOS ACCESSORIES ACCESSOIRES		
CODIGO CODE	DESIGNAÇÃO DESIGNATION NOMINATION	QUANTIDADE QUANTITY QUANTITE
205162	CARRINHO OS Nº5 ROLLER BEARING ROULEAU	4
205161	CARRINHO-GUIA OS SUPERIOR Nº3 UPPER-GUIDE ROLLER BEARING N3 ROULEAU-GUIDE SUPÉRIEUR N3	4
205172	ESQUADRO 18-2210-D BLOCKING BRACKET ÉQUERRE	8
213018	CANTO DE ALINHAMENTO OS N.2 ANGLE ANGLE	8
202323	CONTRA-FECHO OS INOX C/ AFINAÇÃO Nº2 COUNTER-LOCK BRACKET CONTRE-FERMETURE SUPPORT	6
213220	AMORTECEDOR OS N.3 SHOCK ABSORBER AMORTISSEUR	4
201089	FECHO LATERAL OS Nº4 Nº4 LATERAL LOCK SERRURE LATÉRALE Nº4	2
280000	TESTA OS-D P/FECHO OS N.2 STRIKING PLATE GÂCHE	6
215037	PEÇA AJUSTE P/FECHO LAT OS N.4 ADJUSTMENT PIECE PIÈCE DE RÉGLAGE	8
228166	MOLA PARA RETENÇÃO DE FECHO OS OS LOCK RETAINER SPRING RESSORT DE RETENUE POUR FERMETURE OS	2
210094	TOPO CENTRAL Nº2 OS-V2 ESQUERDO CENTRAL Nº2 LEFT END-CAP EMBOUT CENTRAL Nº2 GAUCHE	2
210095	TOPO CENTRAL Nº2 OS-V2 DIREITO CENT. Nº2 RIGHT END-CAP EMBOUT CENT. Nº2 DROITE	2
210165	TOPO LATERAL SUP/INF Nº15 OS-V2 LATERAL UPPER/LOWER Nº15 OS-V2 END-CAP EMBOUT LAT SUP/INF Nº15 OS-V2	4
213273	CORTA-VENTO OS SUPERIOR UPPER CENTRAL GASKET PIÈCE D'ÉTANCHEÏTE SUPÉRIEUR	1
213274	CORTA-VENTO OS INFERIOR LOWER CENTRAL GASKET PIÈCE D'ÉTANCHEÏTE INFÉRIEUR	1
212065	CONJUNTO TOPOS OS 51 OS 51 END-CAP KIT KIT D'EMBOUT OS 51	2
212066	CONJUNTO TOPOS OS 61 OS 61 END-CAP KIT KIT D'EMBOUT OS 61	2
210268	GOTEIRA C/ VÁLVULA SVE FLAP VALVE CLAPET À VOLET	DIVERSOS DIVERS DIVERS
210265	GOTEIRA C/ VÁLVULA BOLA BALL VALVE CLAPET À BILLE	DIVERSOS DIVERS DIVERS
290020	PARAFUSO PAR 006 SCREW VIS	DIVERSOS DIVERS DIVERS
215078	PEÇA ANTI-LEVANTAMENTO OS ANTI-LIFT ACCESSORY ANTI-LEVAGE ACCESSOIRE	2
215083	ANTI-LEVANTAMENTO GUIA INOX OS OS GUIDE ANTI-LIFT ACCESSORY ACCESSOIRE ANTI-LEVAGE POUR GUIDE INOX OS	4
215194	CHAPA BLOQUEIO PELÚCIA PILE SEAL LOCK PLATE PLAQUE DE VERROUILLAGE DE JOINT BROSSÉ	4
210510	TOPO BLOQUEIO PELÚCIA CV PILE SEAL LOCK END-CAP CV EMBOUT DE VERROUILLAGE DE JOINT BROSSÉ CV	4
212246	CONJ. TOPOS CAL/SOL OS-D 2-RAIL DRAINAGE CHANNEL/SEUIL OS-D 2-RAIL END-CAP KIT KIT D'EMBOUT DE GOUTTIÈRE/SEUIL OS-D 2-RAIL	1

* Opcional | Optional | Optionnel

VEDANTES SEALENTS JOINTS		
CODIGO CODE	DESIGNAÇÃO DESIGNATION NOMINATION	QUANTIDADE QUANTITY QUANTITE
208450 ou or ou	PELÚCIA 7x5.5 Cinza PILE SEAL JOINT BROSSÉ	8L
208465	PELÚCIA 7x5.5 Preta PILE SEAL JOINT BROSSÉ	8L
208460	PELÚCIA 7x7 S-F PILE SEAL JOINT BROSSÉ	6H
208597	PELÚCIA SRF SRF 4X8X100 2P1M PILE SEAL JOINT BROSSÉ	4un.
208499	VD 2063.N	2H
208193	VD 2060	2L

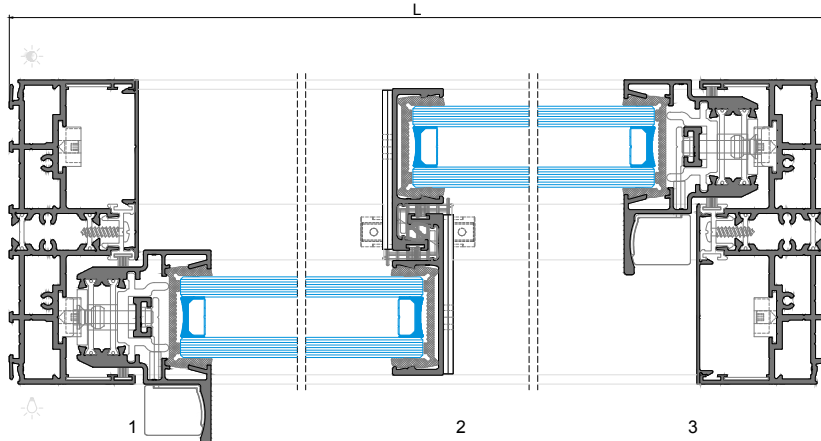
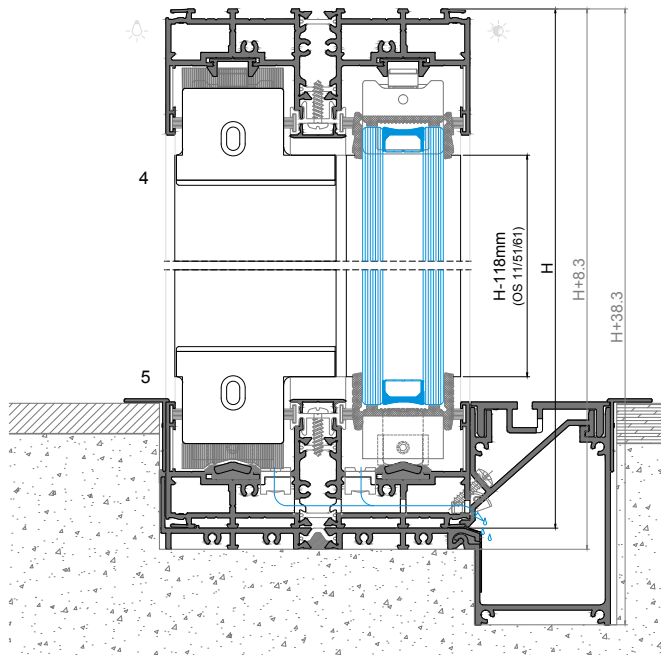

JANELA DE CORRER 4 FOLHAS (2+2) EM CANTO 90° - COM PERFIL SO 10
4 SASHES (2+2) 90° CORNER SLIDING WINDOW - WITH SO 10 PROFILE
FENÊTRE COULISSANT 4 VANTAOX (2+2) À ANGLE 90° - AVEC PROFILÉ SO 10

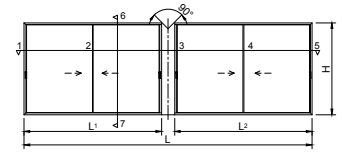

PERFIS PROFILES PROFILÉS					
CODIGO CODE	DESIGNAÇÃO DESIGNATION NOMINATION	CORTE HORIZ. HORIZONTAL DETAIL DETAIL HORIZONTAL	CORTE VERT. VERTICAL DETAIL DETAIL VERTICALE	QUANT. QUANTITY QUANTITÉ	CORTE CUT COUPE
SO 11	ARO FIXO FIXED FRAME DORMANT	L1 L2	H	2 + 2	
SO 65	ARO MÓVEL LATERAL MOBILE FR. OUVRANT	-	H-118	3	
SO 30	VARETA ROD PROFILE TIGE	-	VARIÁVEL VARIABLE VARIABLE	3	
SO 10	ARO MÓVEL CANTO MOBILE FR. OUVRANT	-	H-114	1	
OS 61	ARO MÓVEL CENTRAL PROFILE PROFILÉ	-	H-118	4	
SO 60	TAMPA DE CANAL TRACK COVER PROFILÉ CACHE CANAL	-	H-46	2	
OS 35	GUIA SUP. UPPER GUIDE GUIDE SUPÉRIEUR	L1-106 L1-39 L2-106 L2-39	-	1 1 1 1	
OS 801	GUIA INF. INOX LOWER GUIDE GUIDE INFÉRIEUR	Conforme esquema According to scheme Selon schéma			
OS 95	POLIAMIDA POLYAMIDE POLYAMIDE	(L1-89)/2 (L1-133)/2 (L2-124)/2 (L2-99)/2	H-74	2 2 2 2	
OS 30	PERFIL REMATE PROFILE PROFILÉ	L1/2-80 L1/2-97 L2/2-77 L2/2-50	-	2 2 2 2	
SO 82	PERFIL SOLEIRA SILL PROFILE PROFILÉ DE SEUIL	CONSULTAR DEPARTAMENTO TÉCNICO CONSULT TECHNICAL DEPARTMENT CONSULTER DÉPARTEMENT TECHNIQUE			
SO 25	PERFIL CALEIRA DRAINAGE CHANNEL GOUTTIÈRE DE VIDANGE				
SO 58	TAMPA DE CALEIRA GRID GRILLE POUR GOUTTIÈRE DE VIDANGE				
VO 11	PERFIL FIXAÇÃO TAMPA DRAINAGE (1) CHANNEL GRID FIX. PROF. PROF. FIXATION GRILLE				

(1) Peças com 400mm, aplicadas aproximadamente a cada 800mm | Pieces 400mm long, applied approximately every 800mm | Pièces de 400 mm, appliquées à environ tous les 800 mm

VEDANTES SEALENTS JOINTS		
CODIGO CODE	DESIGNAÇÃO DESIGNATION NOMINATION	QUANTIDADE QUANTITY QUANTITÉ
208450	PELÚCIA 7x5.5 Cinza PILE SEAL JOINT BRASSE	8L1 + 8L2
208465	PELÚCIA 7x5.5 Preta PILE SEAL JOINT BRASSE	
208460	PELÚCIA 7x7 S-F PILE SEAL JOINT BRASSE	10H
208597	PELÚCIA SRF SRF 4X8X100 2P1M PILE SEAL JOINT BRASSE	8un.
208499	VD 2063.N	4H
208193	VD 2060	2L1 + 2L2

ACESSÓRIOS ACCESSORIES ACCESSOIRES		
CODIGO CODE	DESIGNAÇÃO DESIGNATION NOMINATION	QUANTIDADE QUANTITY QUANTITÉ
205162	CARRINHO OS Nº5 ROLLER BEARING ROULEAU	8
205161	CARRINHO-GUIA OS SUPERIOR Nº3 UPPER-GUIDE ROLLER BEARING N3 ROULEAU-GUIDE SUPÉRIEUR N3	8
205172	ESQUADRO 18-2210-D BLOCKING BRACKET ÉQUERRE	8
213018	CANTO DE ALINHAMENTO OS N.2 ANGLE ANGLE	8
202323	CONTRA-FECHO OS INOX C/ AFINAÇÃO Nº2 COUNTER-LOCK BRACKET CONTRE-FERMETURE SUPPORT	9
213220	AMORTECEDOR OS N.3 SHOCK ABSORBER AMORTISSEUR	6
280000	TESTA OS-D P/FECHO OS N.2 STRIKING PLATE GÂCHE	9
201089	FECHO LATERAL OS Nº4 Nº4 LATERAL LOCK SERRURE LATÉRALE Nº4	3
215037	PEÇA AJUSTE P/FECHO LAT OS N.4 ADJUSTMENT PIECE PIÈCE DE RÉGLAGE	12
228186	MOLA PARA RETENÇÃO DE FECHO OS OS LOCK RETAINER SPRING RESSORT DE RETENUE POUR FERMETURE OS	3
210094	TOPO CENTRAL Nº2 OS-V2 ESQUERDO CENTRAL Nº2 LEFT END-CAP EMBOUT CENTRAL Nº2 GAUCHE	4
210095	TOPO CENTRAL Nº2 OS-V2 DIREITO CENT. Nº2 RIGHT END-CAP EMBOUT CENT. Nº2 DROITE	4
210165	TOPO LATERAL SUP/INF Nº15 OS-V2 LATERAL UPPER/LOWER Nº15 OS-V2 END-CAP EMBOUT LAT SUP/INF Nº15 OS-V2	6
213273	CORTA-VENTO OS SUPERIOR UPPER CENTRAL GASKET PIÈCE D'ÉTANCHÉITE SUPÉRIEUR	2
213274	CORTA-VENTO OS INFERIOR LOWER CENTRAL GASKET PIÈCE D'ÉTANCHÉITE INFÉRIEUR	2
212297	CONJ. TOPOS SUP/INF SO 10 DIRT RIGHT SO 10 END-CAP KIT KIT D'EMBOUT SO 10 GOUCHE	1
212299	CONJ. TOPOS SUP/INF SO 10 ESO LEFT SO 10 END-CAP KIT KIT D'EMBOUT SO 10 GOUCHE	1
212066	CONJUNTO TOPOS OS 61 OS 61 END-CAP KIT KIT D'EMBOUT OS 61	4 *
210268	GOTEIRA C/ VÁLVULA SVE FLAP VALVE CLAPET À VOLET	DIVERSOS DIVERSES DIVERS
210265	GOTEIRA C/ VÁLVULA BOLA BALL VALVE CLAPET À BILLE	DIVERSOS DIVERSES DIVERS
290020	PARAFUSO PAR 006 SCREW VIS	DIVERSOS DIVERSES DIVERS
215078	PEÇA ANTI-LEVANTAMENTO OS ANTI-LIFT ACCESSORY ANTI-LEVAGE ACCESSOIRE	3
215083	ANTI-LEVANTAMENTO GUIA INOX OS OS GUIDE ANTI-LIFT ACCESSORY ACCESSOIRE ANTI-LEVAGE POUR GUIDE INOX OS	4
215194	CHAPA BLOQUEIO PELÚCIA PILE SEAL LOCK PLATE PLAQUE DE VERROUILLAGE DE JOINT BRASSE	8
210510	TOPO BLOQUEIO PELÚCIA CV PILE SEAL LOCK END-CAP CV EMBOUT DE VERROUILLAGE DE JOINT BRASSE CV	8
212246	CONJ. TOPOS CAL/SOL OS-D 2-RAIL DRAINAGE CHANNEL/SILL OS-D 2-RAIL END-CAP KIT KIT D'EMBOUT DE GOUTTIÈRE/SEUIL OS-D 2-RAIL	1

* Opcional | Optional | Optionnel

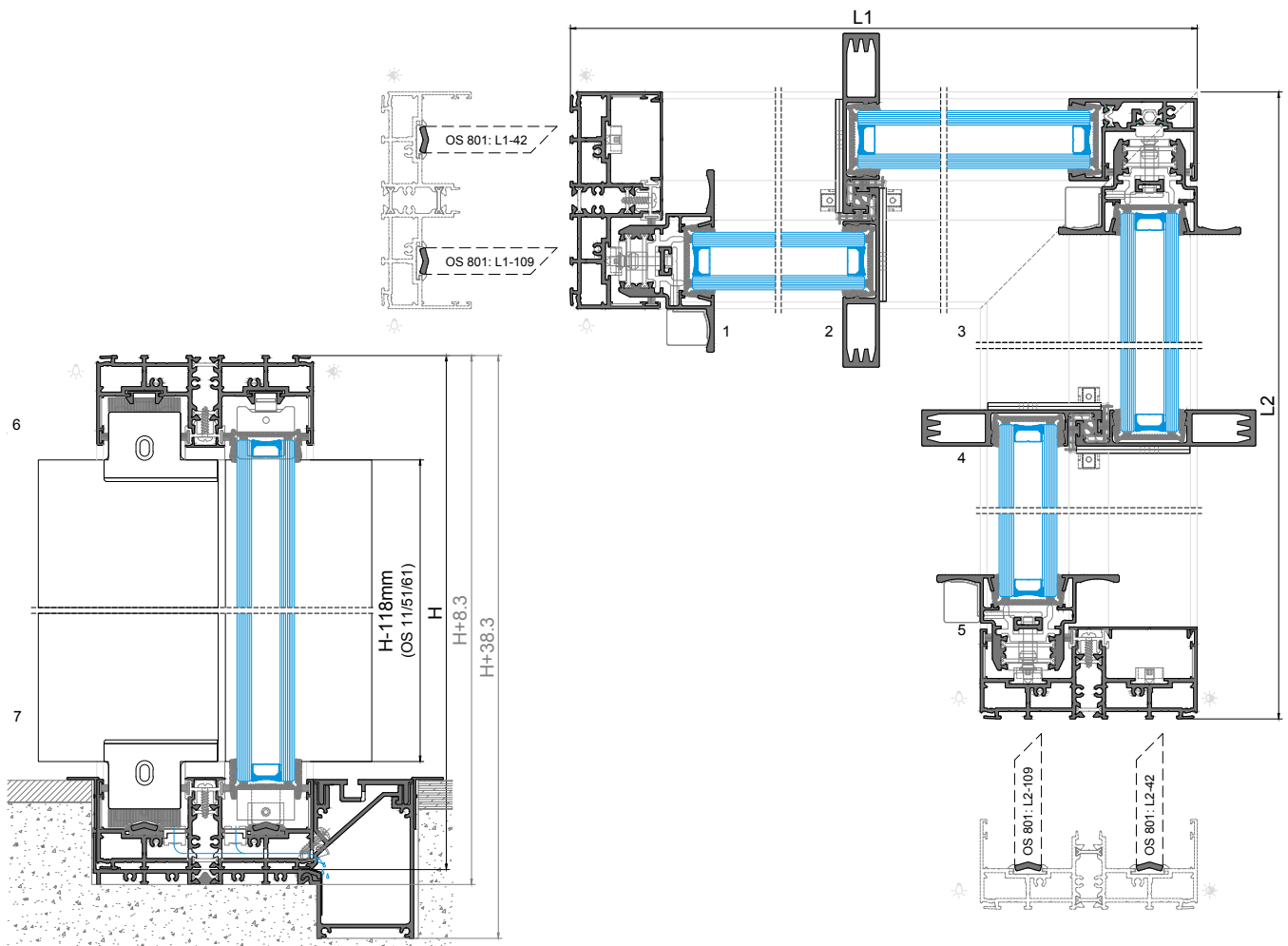

JANELA DE CORRER 4 FOLHAS - COM PERFIL OS 27
4 SASHES SLIDING WINDOW - WITH OS 27 PROFILE
FENÊTRE COULISSANT 4 VANTAUX - AVEC PROFILÉ OS 27

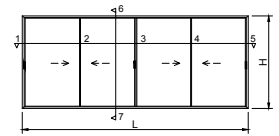

PERFIS PROFILES PROFILÉS					
CÓDIGO CODE	DESIGNAÇÃO DESIGNATION NOMINATION	CORTE HORIZ. HORIZONTAL-DETAIL DETAIL HORIZONTAL	CORTE VERT. VERTICAL-DETAIL DETAIL VERTICALE	QUANT. CUT QUANTITÉ	CORTE CUT GOUPE
ISO 11	ARO FIXO FIXED FRAME DORMANT	L	H	2+2	
OS 27	PERFIL UNIÃO 3/4 F UNION PROFILE PROFILÉ D'UNION	-	H-118	1	
OS 61	ARO MÓVEL CENTRAL PROFILE PROFILÉ	-	H-118	4	
SO 65	ARO MÓVEL LATERAL MOBILE FR. OUVRIANT	-	H-118	3	
SO 30	VARETA ROD PROFILE TIGE	-	VARIÁVEL VARIABLE VARIABLE	3	
SO 60	TAMPA DE CANAL TRACK COVER PROFILÉ CACHE CANAL	-	H-46	2	
OS 35	GUIA SUP. UPPER GUIDE GUIDE SUPÉRIEUR	L-46	-	2	
OS 801	GUIA INF. INOX LOWER GUIDE GUIDE INFÉRIEUR	L-46	-	2	
OS 95	POLIAMIDA POLYAMIDE POLYAMIDE	(L-132)/4 (L-115)/2	H-74	4 + 2	
OS 30	PERFIL REMATE PROFILE PROFILÉ	(L/2)-60 (L/4)-49	-	2 4	
SO 82	PERFIL SOLEIRA SILL PROFILE PROFILÉ DE SEUIL	CONSULTAR DEPARTAMENTO TÉCNICO CONSULT TECHNICAL DEPARTMENT CONSULTER DÉPARTEMENT TECHNIQUE			
SO 25	PERFIL CALEIRA DRAINAGE CHANNEL GOUTTIÈRE DE VIDANGE				
SO 58	TAMPA DE CALEIRA DRAINAGE CHANNEL GRID GRILLE POUR GOUTTIÈRE DE VIDANGE				
VO 11	PERFIL FIXAÇÃO TAMPA DRAINAGE (1) CHANNEL GRID FIX. PROF. PROF. FIXATION GRILLE				

(1) Peças com 400mm, aplicadas aproximadamente a cada 800mm | Pieces 400mm long, applied approximately every 800mm | Pièces de 400 mm, appliquées à environ tous les 800 mm

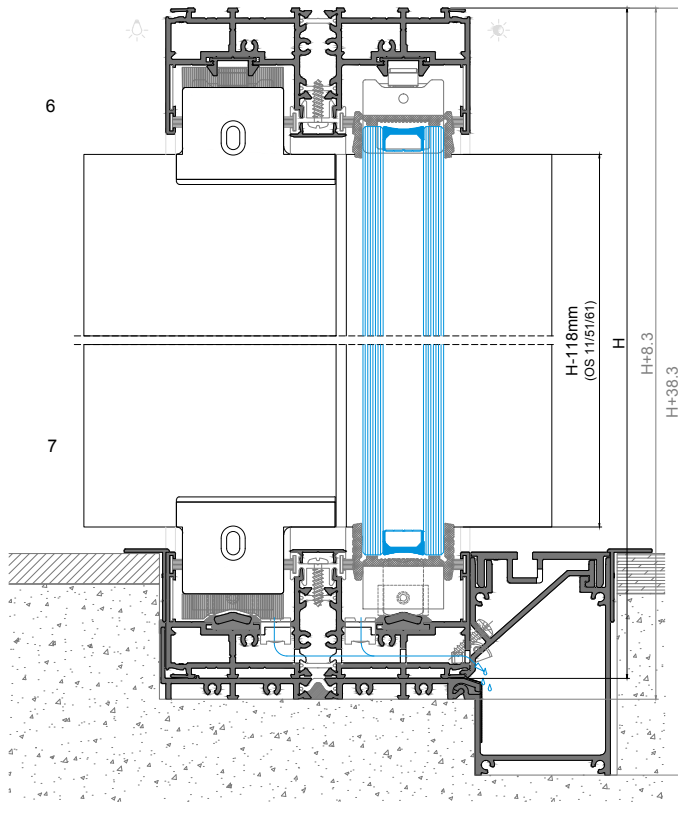

ACESSÓRIOS ACCESSORIES ACCESSOIRES		
CÓDIGO CODE	DESIGNAÇÃO DESIGNATION NOMINATION	QUANTIDADE QUANTITY QUANTITÉ
205162	CARRINHO OS Nº5 ROLLER BEARING ROULEAU	8
205161	CARRINHO-GUIA OS SUPERIOR Nº3 UPPER-GUIDE ROLLER BEARING N3 ROULEAU-GUIDE SUPÉRIEUR N3	8
205172	ESQUADRO 18-2210-D BLOCKING BRACKET ÉQUERRE	8
213018	CANTO DE ALINHAMENTO OS N.2 ANGLE ANGLE	8
202323	CONTRA-FECHO OS INOX C/ AFINAÇÃO Nº2 COUNTER-LOCK BRACKET CONTRE-FERMETURE SUPPORT	9
213220	AMORTECEDOR OS N.3 SHOCK ABSORBER AMORTISSEUR	6
201089	FECHO LATERAL OS Nº4 Nº4 LATERAL LOCK SERRURE LATÉRALE Nº4	3
280000	TESTA OS-D P/FECHO OS N.2 STRIKING PLATE GÂCHE	9
215037	PEÇA AJUSTE P/FECHO LAT OS N.4 ADJUSTMENT PIECE PIECE DE REGLAGE	12
228166	MOLA PARA RETENÇÃO DE FECHO OS OS LOCK RETAINER SPRING RESSORT DE RETENUE POUR FERMETURE OS	3
210094	TOPO CENTRAL Nº2 OS-V2 ESQUERDO CENTRAL Nº2 LEFT END-CAP EMBOUT CENTRAL Nº2 GAUCHE	4
210095	TOPO CENTRAL Nº2 OS-V2 DIREITO CENT. Nº2 RIGHT END-CAP EMBOUT CENT. Nº2 DROITE	4
210165	TOPO LATERAL SUP/INF Nº15 OS-V2 LATERAL UPPER/LOWER Nº15 OS-V2 END-CAP EMBOUT LAT SUP/INF Nº15 OS-V2	6
213273	CORTA-VENTO OS SUPERIOR UPPER CENTRAL GASKET PIÈCE D'ÉTANCHÉITE SUPÉRIEUR	2
213274	CORTA-VENTO OS INFERIOR LOWER CENTRAL GASKET PIÈCE D'ÉTANCHÉITE INFÉRIEUR	2
212066	CONJUNTO TOPOS OS 61 OS 61 END-CAP KIT KIT D'EMBOUT OS 61	*
212124	CONJ. TOPOS PARA OS 27 END-CAPS EMBOUT	2
210268	GOTEIRA C/ VÁLVULA SVE FLAP VALVE CLAPET À VOILE	DIVERSOS DIVERS DIVERS
210265	GOTEIRA C/ VÁLVULA BOLA BALL VALVE CLAPET À BILLE	DIVERSOS DIVERS DIVERS
290020	PARAFUSO PAR 006 SCREW VIS	DIVERSOS DIVERS DIVERS
215078	PEÇA ANTI-LEVANTAMENTO OS ANTI-LIFT ACCESSORY ANTI-LEVAGE ACCESSOIRE	2
215083	ANTI-LEVANTAMENTO GUIA INOX OS OS GUIDE ANTI-LIFT ACCESSORY ACCESSOIRE ANTI-LEVAGE POUR GUIDE INOX OS	4
215194	CHAPA BLOQUEIO PELÚCIA PILE SEAL LOCK PLATE PLAQUE DE VERROUILLAGE DE JOINT BRASSE	8
210510	TOPO BLOQUEIO PELÚCIA CV PILE SEAL LOCK END-CAP CV EMBOUT DE VERROUILLAGE DE JOINT BRASSE CV	8
212246	CONJ. TOPOS CAL/SOL OS-D 2-RAIL DRAINAGE CHANNEL/SILL OS-D 2-RAIL END-CAP KIT KIT D'EMBOUT DE GOUTTIÈRE/SEUIL OS-D 2-RAIL	1

* Opcional | Optional | Optionnel

VEDANTES SEALENTS JOINTS		
CÓDIGO CODE	DESIGNAÇÃO DESIGNATION NOMINATION	QUANTIDADE QUANTITY QUANTITÉ
208450	PELÚCIA 7x5.5 Cinza ou or ou	8L
208465	PELÚCIA 7x5.5 Preta ou or ou	8L
208460	PELÚCIA 7x7 S-F PILE SEAL JOINT BRASSE	10H
208597	PELÚCIA SRF SRF 4X8X100 2P1M PILE SEAL JOINT BRASSE	8un.
208499	VD 2063.N	4H
208193	VD 2060	2L

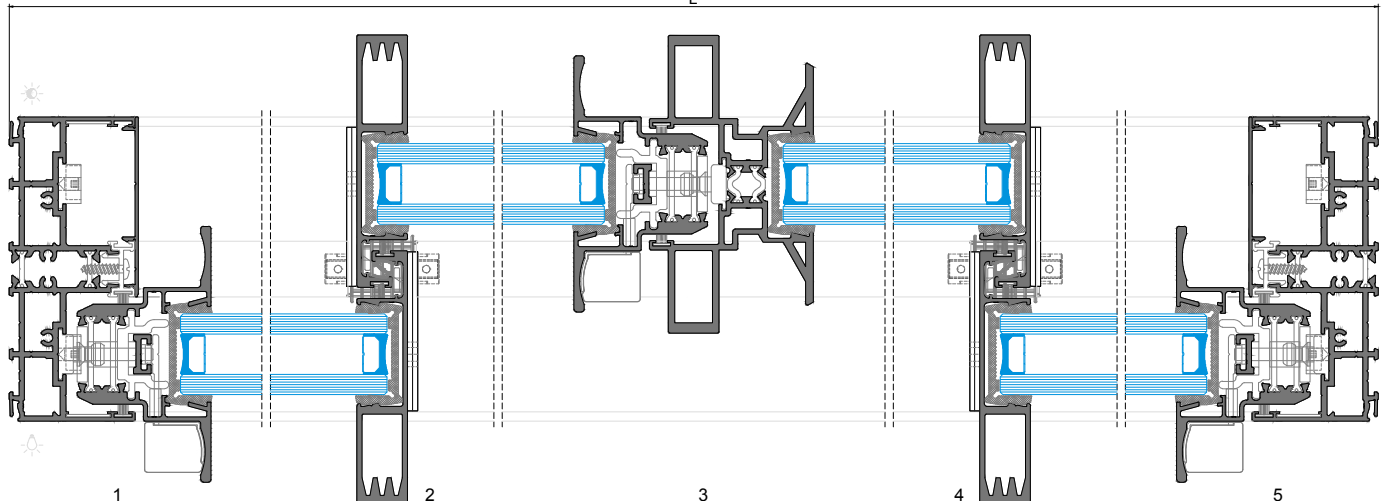

JANELA DE CORRER 4 FOLHAS - COM PERFIS SO 38 + SO 39
4 SASHES SLIDING WINDOW - WITH SO 38 + SO 39 PROFILES
FENÊTRE COULISSANT 4 VANTAOX - AVEC PROFILÉS SO 38 + SO 39

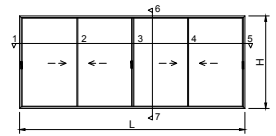

PERFIS PROFILES PROFILÉS					
CODIGO CODE	DESIGNAÇÃO DESIGNATION NOMINATION	CORTE HORIZ. HORIZONTAL DETAIL DÉTAIL HORIZONTAL	CORTE VERT. VERTICAL DETAIL DÉTAIL VERTICALE	QUANT. QUANTITY QUANTITÉ	CORTE CUT COUPE
SO 11	ARO FIXO FIXED FRAME DORMANT	L	H	2+2	
OS 61	ARO MÓVEL CENTRAL PROFILE PROFILÉ	-	H-118	4	
SO 38	PERFIL CENTRAL CONTRA FECHO PROFILE PROFILÉ	-	H-73	1	
SO 39	PERFIL CENTRAL FECHO PROFILE PROFILÉ	-	H-73	1	
SO 65	ARO MÓVEL LATERAL MOBILE FR. OUVRANT	-	H-118	2	
SO 30	VARETA ROD PROFILE TIGE	-	VARIÁVEL VARIABLE VARIABLE	2	
SO 33	BARRA DE CREMONE DUPLA DOUBLE CREMONE ROD TIGE CREMONE DOUBLE	-	VARIÁVEL VARIABLE VARIABLE	4	
SO 60	TAMPA DE CANAL TRACK COVER PROFILE CACHE CANAL	-	H-46	2	
OS 35	GUIA SUP. UPPER GUIDE GUIDE SUPÉRIEUR	L-46	-	2	
OS 801	GUIA INF. INOX LOWER GUIDE GUIDE INFÉRIEUR	L-46	-	2	
OS 95	POLIAMIDA POLYAMIDE POLYAMIDE	(L-85)/4 (L-212)/4	H-74	4 + 2	
OS 30	PERFIL REMATE PROFILE PROFILÉ	(L-147)/4 (L-220)/4	-	4	
SO 82	PERFIL SOLEIRA SILL PROFILE PROFILÉ DE SEUIL	CONSULTAR DEPARTAMENTO TÉCNICO CONSULT TECHNICAL DEPARTMENT CONSULTER DÉPARTEMENT TECHNIQUE			
SO 25	PERFIL CALEIRA DRAINAGE CHANNEL GOUTTIÈRE DE VIDANGE				
SO 58	TAMPA DE CALEIRA GRID GRILLE POUR GOUTTIÈRE DE VIDANGE				
VO 11	PERFIL FIXAÇÃO TAMPA DRAINAGE (1) CHANNEL GRID FIX. PROF. PROF. FIXATION GRILLE				

(1) Peças com 400mm, aplicadas aproximadamente a cada 800mm | Pieces 400mm long, applied approximately every 800mm | Pièces de 400 mm, appliquées à environ tous les 800 mm

ACESSÓRIOS ACCESSORIES ACCESSOIRES		
CODIGO CODE	DESIGNAÇÃO DESIGNATION NOMINATION	QUANTIDADE QUANTITY QUANTITÉ
205162	CARRINHO OS Nº5 ROLLER BEARING ROULEAU	8
205161	CARRINHO-GUIA OS SUPERIOR Nº3 UPPER-GUIDE ROLLER BEARING N3 ROULEAU-GUIDE SUPÉRIEUR N3	8
205172	ESQUADRO 18-2210-D BLOCKING BRACKET ÉQUERRE	8
213018	CANTO DE ALINHAMENTO OS N.2 ANGLE ANGLE	8
202323	CONTRA-FECHO OS INOX C/ AFINAÇÃO Nº2 COUNTER-LOCK BRACKET CONTRE-FERMETURE SUPPORT	6
213220	AMORTECEDOR OS N.3 SHOCK ABSORBER AMORTISSEUR	4
201089	FECHO LATERAL OS Nº4 Nº4 LATERAL LOCK SERRURE LATÉRALE Nº4	2
280000	TESTA OS-D P/FECHO OS N.2 STRIKING PLATE GÂCHE	6
215037	PEÇA AJUSTE P/FECHO LAT OS N.4 ADJUSTMENT PIECE PIÈCE DE RÉGLAGE	8
228186	MOLA PARA RETENÇÃO DE FECHO OS OS LOCK RETAINER SPRING RESSORT DE RETENUE POUR FERMETURE OS	2
210094	TOPO CENTRAL Nº2 OS-V2 ESQUERDO CENTRAL Nº2 LEFT END-CAP EMBOUT CENTRAL Nº2 GAUCHE	4
210095	TOPO CENTRAL Nº2 OS-V2 DIREITO CENT. Nº2 RIGHT END-CAP EMBOUT CENT. Nº2 DROITE	4
201065	TOPO LATERAL SUP/INF Nº15 OS-V2 LATERAL UPPER/LOWER Nº15 OS-V2 END-CAP EMBOUT LAT SUP/INF Nº15 OS-V2	4
213273	CORTA-VENTO OS SUPERIOR UPPER CENTRAL GASKET PIÈCE D'ÉTANCHÉITE SUPÉRIEUR	3
213274	CORTA-VENTO OS INFERIOR LOWER CENTRAL GASKET PIÈCE D'ÉTANCHÉITE INFÉRIEUR	3
212066	CONJUNTO TOPOS OS 61 OS 61 END-CAP KIT KIT D'EMBOUT OS 61	4
210268	GOTEIRA C/ VÁLVULA SVE FLAP VALVE CLAPET À VOILE	DIVERSOS DIVERSES DIVERS
210265	GOTEIRA C/ VÁLVULA BOLA BALL VALVE CLAPET À BILLE	DIVERSOS DIVERSES DIVERS
290020	PARAFUSO PAR 006 SCREW VIS	DIVERSOS DIVERSES DIVERS
215078	PEÇA ANTI-LEVANTAMENTO OS ANTI-LIFT ACCESSORY ANTI-LEVAGE ACCESSOIRE	2
215083	ANTI-LEVANTAMENTO GUIA INOX OS OS GUIDE ANTI-LIFT ACCESSORY ACCESSOIRE ANTI-LEVAGE POUR GUIDE INOX OS	4
215194	CHAPA BLOQUEIO PELÚCIA PILE SEAL LOCK PLATE PLAQUE DE VERROUILLAGE DE JOINT BROSSÉ	8
210510	TOPO BLOQUEIO PELÚCIA CV PILE SEAL LOCK END-CAP CV EMBOUT DE VERROUILLAGE DE JOINT BROSSÉ CV	8
290099	PARAFUSO DIN7991 M5x8 INOX A2 SCREW VIS	4
212019	CONJ. TOPOS SO38/SO39 END-CAP KIT KIT D'EMBOUT	1
201097	FECHO EMBUTIR OS MONODIRECIONAL LOCK SERRURE	1
212000	CONJ. FECHO SO38/SO39 LOCK SET KIT FERMETURE	1

* Opcional | Optional | Optionnel

** 2Un./prumada para alturas até 3metros. 3Un./prumada para alturas superiores a 3 metros
2units/union for heights up to 3 meters. 3 units/union for heights over 3 meters | 2 unités/union pour les hauteurs jusqu'à 3 mètres. 3 unités/union pour les hauteurs supérieures à 3 mètres

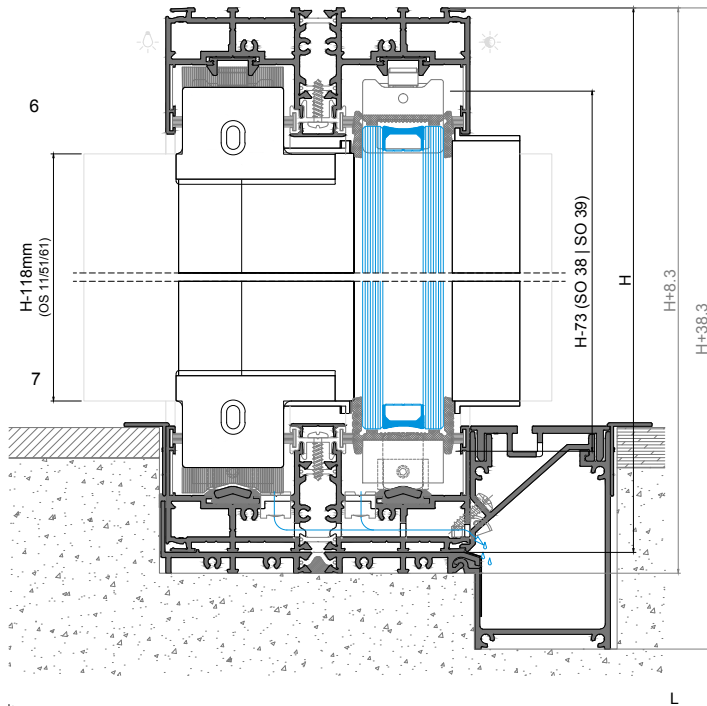

VEDANTES SEALENTS JOINTS		
CODIGO CODE	DESIGNAÇÃO DESIGNATION NOMINATION	QUANTIDADE QUANTITY QUANTITÉ
208450 ou or ou 208465	PELÚCIA 7x5.5 Cinza PILE SEAL JOINT BROSSÉ ou or ou PELÚCIA 7x5.5 Preta PILE SEAL JOINT BROSSÉ	8L
208460	PELÚCIA 7x7 S-F PILE SEAL JOINT BROSSÉ	8H
208450 ou or ou 208465	PELÚCIA 7x5.5 PILE SEAL JOINT BROSSÉ ou or ou PELÚCIA 7x5.5 PILE SEAL JOINT BROSSÉ	3H
208499	VD 2063.N	6H
208193	VD 2060	2L
208225	VD 2050	1H

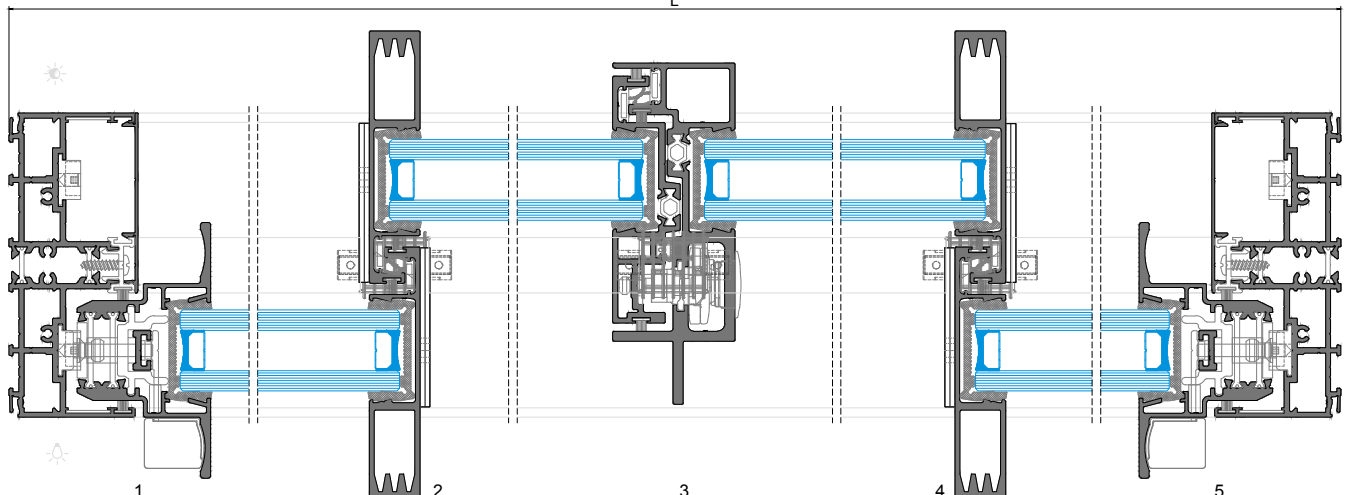

JANELA DE CORRER 3 FOLHAS
3 SASHES SLIDING WINDOW
FENÊTRE COULISSANT 3 VANTAUX

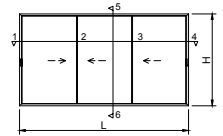

PERFIS PROFILES PROFILÉS					
CÓDIGO CODE	DESIGNAÇÃO DESIGNATION NOMINATION	CORTE HORIZ. HORIZONTAL DETAIL	CORTE VERT. VERTICAL DETAIL	QUANT. CUT QUANTITÉ	CORTE CUT GOUPE
SO 12	ARO FIXO FIXED FRAME DORMANT	L	H	2+2	
OS 61	ARO MÓVEL CENTRAL PROFILE PROFILÉ	-	H-118	4	
SO 30	VARETA ROD PROFILE TIGE	-	VARIÁVEL VARIABLE VARIABLE	2	
SO 61	TAMPA DE CANAL TRACK COVER PROFILÉ CACHE CANAL	-	H-46	2	
SO 66	ARO MÓVEL LATERAL MOBILE FR. LOUVRANT	-	H-118	2	
OS 35	GUIA SUP. UPPER GUIDE GUIDE SUPÉRIEUR	L-46	-	3	
OS 801	GUIA INF. INOX LOWER GUIDE GUIDE INFÉRIEUR	L-46	-	3	
OS 95	POLIAMIDA POLYAMIDE POLYAMIDE	(L/3)-26.5 (L/3)-36.5)x2 (L/3)-44)x2 (L/3)-42	H-74	4+4 4 4	
OS 30	PERFIL REMATE PROFILE PROFILÉ	-	-	4	
SO 84	PERFIL SOLEIRA SILL PROFILE PROFILÉ DE SEUIL	CONSULTAR DEPARTAMENTO TÉCNICO CONSULT TECHNICAL DEPARTMENT CONSULTER DÉPARTEMENT TECHNIQUE			
SO 25	PERFIL CALEIRA DRAINAGE CHANNEL GOUTTIÈRE DE VIDANGE				
SO 58	TAMPA DE CALEIRA DRAINAGE CHANNEL GRID GRILLE POUR GOUTTIÈRE DE VIDANGE				
VO 11	PERFIL FIXAÇÃO TAMPA DRAINAGE (1) CHANNEL GRID FIX. PROF. PROF. FIXATION GRILLE				

(1) Peças com 400mm, aplicadas aproximadamente a cada 800mm | Pieces 400mm long, applied approximately every 800mm | Pièces de 400 mm, appliquées à environ tous les 800 mm

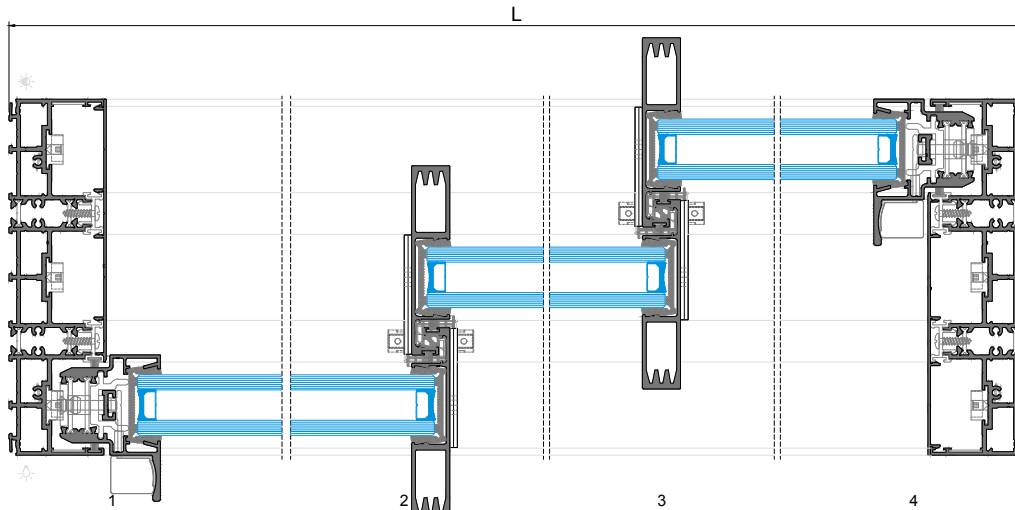
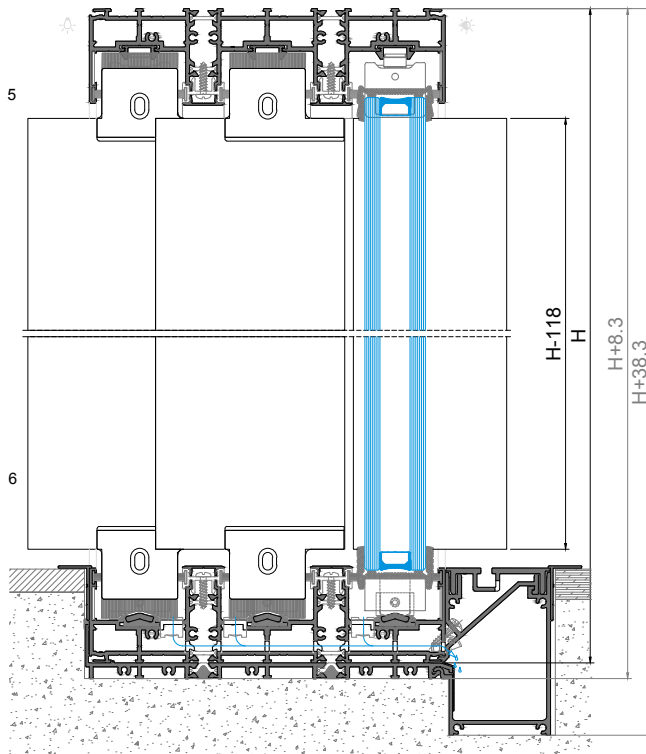

ACESSÓRIOS ACCESSORIES ACCESSOIRES		
CÓDIGO CODE	DESIGNAÇÃO DESIGNATION NOMINATION	QUANTIDADE QUANTITY QUANTITÉ
205162	CARRINHO OS Nº5 ROLLER BEARING ROULEAU	6
205161	CARRINHO-GUIA OS SUPERIOR Nº3 UPPER-GUIDE ROLLER BEARING N3 ROULEAU-GUIDE SUPÉRIEUR N3	6
205172	ESQUADRO 18-2210-D BLOCKING BRACKET ÉQUERRE	16
213018	CANTO DE ALINHAMENTO OS N.2 ANGLE ANGLE	8
202323	CONTRA-FECHO OS INOX C/ AFINAÇÃO Nº2 COUNTER-LOCK BRACKET CONTRE-FERMETURE SUPPORT	6
213220	AMORTECEDOR OS N.3 SHOCK ABSORBER AMORTISSEUR	4
201089	FECHO LATERAL OS Nº4 Nº4 LATERAL LOCK SERRURE LATÉRALE Nº4	2
280000	TESTA OS-D P/FECHO OS N.2 STRIKING PLATE GÂCHE	6
215037	PEÇA AJUSTE P/FECHO LAT OS N.4 ADJUSTMENT PIECE PIÈCE DE RÉGLAGE	8
228186	MOLA PARA RETENÇÃO DE FECHO OS OS LOCK RETAINER SPRING RESSORT DE RETENUE POUR FERMETURE OS	2
210094	TOPO CENTRAL Nº2 OS-V2 ESQUERDO CENTRAL Nº2 LEFT END-CAP EMBOUT CENTRAL Nº2 GAUCHE	4
210095	TOPO CENTRAL Nº2 OS-V2 DIREITO CENT. Nº2 RIGHT END-CAP EMBOUT CENT. Nº2 DROITE	4
210165	TOPO LATERAL SUP/INF Nº15 OS-V2 LATERAL UPPER/LOWER Nº15 OS-V2 END-CAP EMBOUT LAT SUP/INF Nº15 OS-V2	4
213273	CORTA-VENTO OS SUPERIOR UPPER CENTRAL GASKET PIÈCE D'ÉTANCHÉITE SUPÉRIEUR	2
213274	CORTA-VENTO OS INFERIOR LOWER CENTRAL GASKET PIÈCE D'ÉTANCHÉITE INFÉRIEUR	2
212066	CONJUNTO TOPOS OS 61 OS 61 END-CAP KIT KIT D'EMBOUT OS 61	4
210268	GOTEIRA C/ VÁLVULA SVE FLAP VALVE CLAPET À VOLET	DIVERSOS DIVERSES DIVERS
210265	GOTEIRA C/ VÁLVULA BOLA BALL VALVE CLAPET À BILLE	DIVERSOS DIVERSES DIVERS
290020	PARAFUSO PAR 006 SCREW VIS	DIVERSOS DIVERSES DIVERS
215078	PEÇA ANTI-LEVANTAMENTO OS ANTI-LIFT ACCESSORY ANTI-LEVAGE ACCESSOIRE	2
215083	ANTI-LEVANTAMENTO GUIA INOX OS OS GUIDE ANTI-LIFT ACCESSORY ACCESSOIRE ANTI-LEVAGE POUR GUIDE INOX OS	6
215194	CHAPA BLOQUEIO PELÚCIA PILE SEAL LOCK PLATE PLAQUE DE VERROUILLAGE DE JOINT BROSSE	8
210510	TOPO BLOQUEIO PELÚCIA CV PILE SEAL LOCK END-CAP CV EMBOUT DE VERROUILLAGE DE JOINT BROSSE CV	8
212247	CONJ. TOPOS CAL/SOL. OS-D 3-RAIL DRAINAGE CHANNEL/SILL OS-D 3-RAIL END-CAP KIT KIT D'EMBOUT DE GOUTTIÈRE/SEUIL OS-D 3-RAIL	1

* Optional | Optionnel | Optionnel

VEDANTES SEALENTS JOINTS		
CÓDIGO CODE	DESIGNAÇÃO DESIGNATION NOMINATION	QUANTIDADE QUANTITY QUANTITÉ
208450 ou 1 ou 196	PELÚCIA 7x5.5 Cinza PILE SEAL JOINT BROSSE ou or ou	8H
208465	PELÚCIA 7x5.5 Preta PILE SEAL JOINT BROSSE	8H
208460	PELÚCIA 7x7 S-F PILE SEAL JOINT BROSSE	12L
208597	PELÚCIA SRF SRF 4X8X100 2P1M PILE SEAL JOINT BROSSE	8un.
208499	VD 2063.N	4H
208193	VD 2060	3L

JANELA DE CORRER 4 FOLHAS
4 SASHES SLIDING WINDOW
FENÊTRE COULISSANT 4 VANTAUX

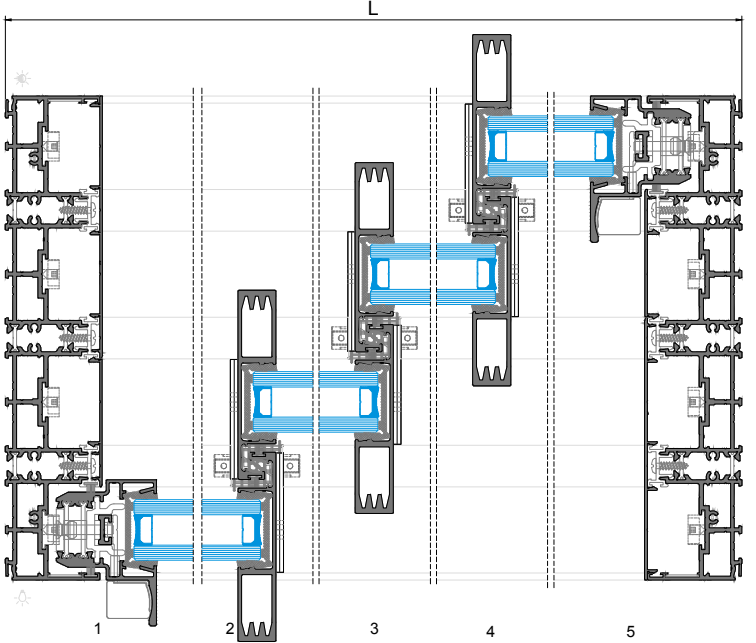
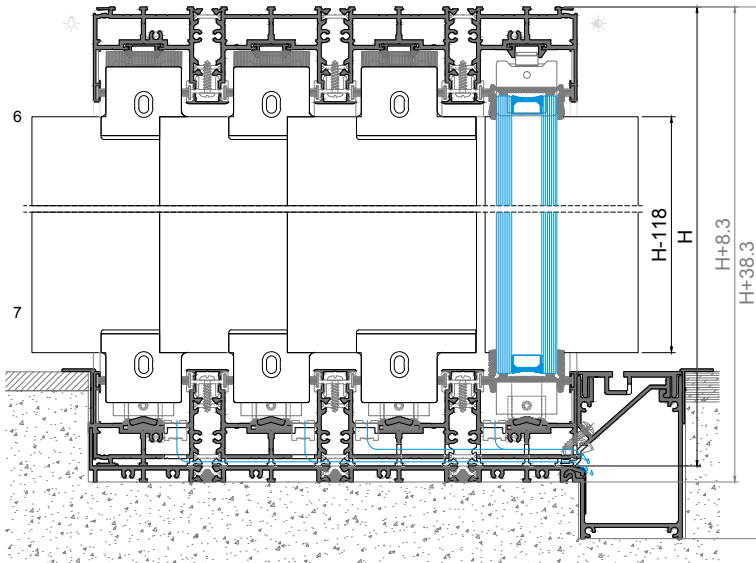
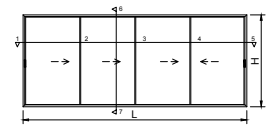

PERFIS PROFILES PROFILÉS					
CÓDIGO CODE	DESIGNAÇÃO DESIGNATION NOMINATION	CORTE HORIZ. HORIZONTAL DETAIL	CORTE VERT. VERTICAL DETAIL	QUANT. QUANTITY	CORTE CUT
SO 13	ARO FIXO FIXED FRAME DORMANT	L	H	2+2	
SO 66	ARO MÓVEL LATERAL MOBILE FR. OUVRANT	-	H-118	2	
SO 30	VARETA ROD PROFILE TIGE	-	VARIÁVEL VARIABLE VARIABLE	2	
OS 61	ARO MÓVEL CENTRAL PROFILE PROFILÉ	-	H-118	6	
OS 801	GUIA INF. INOX LOWER GUIDE GUIDE INFÉRIEUR	L-46	-	4	
OS 35	GUIA SUP. UPPER GUIDE GUIDE SUPÉRIEUR	L-46	-	4	
OS 95	POLIAMIDA POLYAMIDE POLYAMIDE	(L-57)/4 (L-98)/2 (3xL-337)/4	H-74	4 4 + 6	
OS 30	PERFIL REMATE PROFILE PROFILÉ	(L-120)/4 (L-130)/2 (3xL-400)/4	-	4 4	
SO 63	TAMPA DE CANAL TRACK COVER PROFILE CACHE CANAL	-	H-46	2	
SO 61	TAMPA DE CANAL TRACK COVER PROFILE CACHE CANAL	-	H-46	2	
SO 83	PERFIL SOLEIRA SILL PROFILE PROFILE DE SEUIL	CONSULTAR DEPARTAMENTO TÉCNICO CONSULT TECHNICAL DEPARTMENT CONSULTER DÉPARTEMENT TECHNIQUE			
SO 25	PERFIL CALEIRA DRAINAGE CHANNEL GOÛTTIÈRE DE VIDANGE				
SO 58	TAMPA DE CALEIRA DRAINAGE CHANNEL GRID GRILLE POUR GOÛTTIÈRE DE VIDANGE				
VO 11	PERFIL FIXAÇÃO TAMPA DRAINAGE (1) CHANNEL GRID FIX. PROF. PROF. FIXATION GRILLE				

(1) Peças com 400mm, aplicadas aproximadamente a cada 800mm | Pieces 400mm long, applied approximately every 800mm | Pièces de 400 mm, appliquées à environ tous les 800 mm

ACESSÓRIOS ACCESSORIES ACCESSOIRES		
CÓDIGO CODE	DESIGNAÇÃO DESIGNATION NOMINATION	QUANTIDADE QUANTITY QUANTITÉ
205162	CARRINHO OS N°5 ROLLER BEARING ROULEAU	8
205161	CARRINHO-GUIA OS SUPERIOR N°3 UPPER-GUIDE ROLLER BEARING N3 ROULEAU-GUIDE SUPÉRIEUR N3	8
205172	ESQUADRO 18-2210-D BLOCKING BRACKET ÉQUERRE	16
213018	CANTO DE ALINHAMENTO OS N.2 ANGLE ANGLE	8
202323	CONTRA-FECHO OS INOX C/ AFINAÇÃO N°2 COUNTER-LOCK BRACKET CONTRE-FERMETURE SUPPORT	6
213220	AMORTECEDOR OS N.3 SHOCK ABSORBER AMORTISSEUR	4
201089	FECHO LATERAL OS N°4 N°4 LATERAL LOCK SERRURE LATÉRALE N°4	2
280000	TESTA OS-D P/FECHO OS N.2 STRIKING PLATE GÂCHE	6
215037	PEÇA AJUSTE P/FECHO LAT OS N.4 ADJUSTMENT PIECE PIÈCE DE RÉGLAGE	8
226166	MOLA PARA RETENÇÃO DE FECHO OS OS LOCK RETAINER SPRING RESSORT DE RETENUE POUR FERMETURE OS	2
210094	TOPO CENTRAL N°2 OS-V2 ESQUERDO CENTRAL N°2 LEFT END-CAP EMBOUT CENTRAL N°2 GAUCHE	6
210095	TOPO CENTRAL N°2 OS-V2 DIREITO CENT. N°2 RIGHT END-CAP EMBOUT CENT. N°2 DROITE	6
210165	TOPO LATERAL SUP/INF N°15 OS-V2 LATERAL UPPER/LOWER N°15 OS-V2 END-CAP EMBOUT LAT SUP/INF N°15 OS-V2	4
213274	CORTA-VENTO OS SUPERIOR UPPER CENTRAL GASKET PIÈCE D'ÉTANCHÉITE SUPÉRIEUR	3
213273	CORTA-VENTO OS INFERIOR LOWER CENTRAL GASKET PIÈCE D'ÉTANCHÉITE INFÉRIEUR	3
212066	CONJUNTO TOPOS OS 61 OS 61 END-CAP KIT KIT D'EMBOUT OS 61	6
210268	GOTEIRA C/ VÁLVULA SVE FLAP VALVE CLAPET À VOILE	DIVERSOS DIVERSES DIVERS
210265	GOTEIRA C/ VÁLVULA BOLA BALL VALVE CLAPET À BILLE	DIVERSOS DIVERSES DIVERS
290020	PARAFUSO PAR 006 SCREW VIS	DIVERSOS DIVERSES DIVERS
216078	PEÇA ANTI-LEVANTAMENTO OS ANTI-LIFT ACCESSORY ANTI-LEVAGE ACCESSOIRE	2
215083	ANTI-LEVANTAMENTO GUIA INOX OS OS GUIDE ANTI-LIFT ACCESSORY ACCESSOIRE ANTI-LEVAGE POUR GUIDE INOX OS	8
215194	CHAPA BLOQUEIO PELÚCIA PILE SEAL LOCK PLATE PLAQUE DE VERROUILLAGE DE JOINT BRASSE	12
210510	TOPO BLOQUEIO PELÚCIA CV PILE SEAL LOCK END-CAP CV EMBOUT DE VERROUILLAGE DE JOINT BRASSE CV	12
212251	CONJ. TOPOS CAL/SOL OS-D 4-RAIL 4-RAIL END-CAP KIT KIT D'EMBOUT DE GOÛTTIÈRE/SEUIL OS-D 4-RAIL	1

* Opcional | Optional | Optionnel

VEDANTES SEALENTS JOINTS		
CÓDIGO CODE	DESIGNAÇÃO DESIGNATION NOMINATION	QUANTIDADE QUANTITY QUANTITÉ
208450 ou 208460	PELÚCIA 7x5.5 Cinza PILE SEAL JOINT BRASSE ou or ou	16L
208465	PELÚCIA 7x5.5 Preta PILE SEAL JOINT BRASSE	16H
208460	PELÚCIA 7x7 S-F PILE SEAL JOINT BRASSE	10H
208597	PELÚCIA SRF SRF 4X8X100 2P1M PILE SEAL JOINT BRASSE	12un.
208499	VD 2063.N	6H
208193	VD 2060	4L

JANELA DE CORRER DE EMBUTIR COM 1 FOLHA
1 SASH POCKET SLIDING WINDOW
FENÊTRE COULISSANT À GALANDAGE 1 VANTAIL

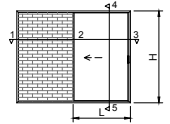

VEDANTES SEALENTS JOINTS		
CODIGO CODE	DESIGNAÇÃO DESIGNATION NOMINATION	QUANTIDADE QUANTITY QUANTITE
208460	PELÚCIA 7x5.5 Cinza PILE SEAL JOINT BRUSSE ou or ou	4L
208465	PELÚCIA 7x5.5 Preta PILE SEAL JOINT BRUSSE	
208460	PELÚCIA 7x7 S-F PILE SEAL JOINT BRUSSE	2H
208897	PELÚCIA SRF 4X8X100 2P1M PILE SEAL JOINT BRUSSE	2H
208193	VD 2060	2L

PERFIS PROFILES PROFILÉS					
CODIGO CODE	DESIGNAÇÃO DESIGNATION NOMINATION	CORTE HORIZ. HORIZONTAL DETAIL DETAIL HORIZONTAL	CORTE VERT. VERTICAL DETAIL DETAIL VERTICAL	QUANT. QUANTITY QUANTITE	CORTE CUT COUPÉ
SO 14	ARO FIXO FIXED FRAME DORMANT	(Lx2)+13	H	2+2	
SO 30	VARETA ROD PROFILE TIGE	-	VARIÁVEL VARIABLE VARIABLE	1	
SO 65	ARO MÓVEL LATERAL MOBILE FR. OUVRANT	-	H-118	1	
OS 801	GUIA INF. INOX LOWER GUIDE GUIDE INFÉRIEUR	(Lx2)-33	-	1	
OS 35	GUIA SUP. UPPER GUIDE GUIDE SUPÉRIEUR	(Lx2)-33	-	1	
AT 30	PERFIL REMATE PROFILE PROFILÉ *	-	H	2	
JF 66	PERFIL REMATE PROFILE PROFILÉ *	-	H	2	
JM 81	PERFIL REMATE PROFILE PROFILÉ *	-	H	1	
SO 80	PERFIL SOLEIRA BILL PROFILE PROFILÉ DE SEUIL	CONSULTAR DEPARTAMENTO TÉCNICO CONSULT TECHNICAL DEPARTMENT CONSULTER DÉPARTEMENT TECHNIQUE			
SO 25	PERFIL CALEIRA DRAINAGE CHANNEL GOUTTIÈRE DE VIDANGE				
SO 58	TAMPA DE CALEIRA DRAINAGE CHANNEL GRID GRILLE POUR GOUTTIÈRE DE VIDANGE				
VO 11	PERFIL FIXAÇÃO TAMPA DRAINAGE CHANNEL GRID FIX. PROF. PROF. FIXATION GRILLE				

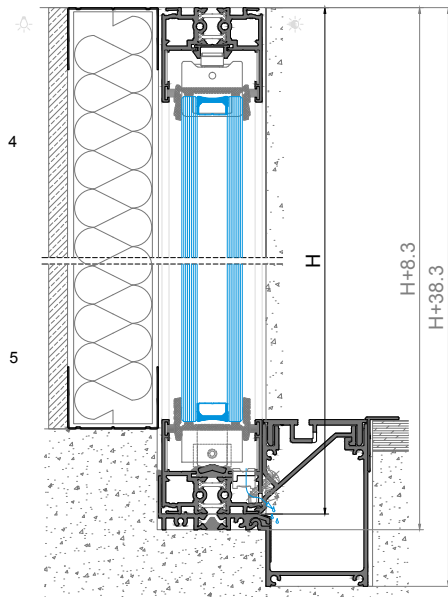

* Opcional | Optional | Optionnel
(1) Peças com 400mm, aplicadas aproximadamente a cada 800mm | Pieces 400mm long, applied approximately every 800mm | Pièces de 400 mm, appliquées à environ tous les 800 mm

ACESSÓRIOS ACCESSORIES ACCESSOIRES		
CODIGO CODE	DESIGNAÇÃO DESIGNATION NOMINATION	QUANTIDADE QUANTITY QUANTITE
205162	CARRINHO OS N°5 ROLLER BEARING ROULEAU	2
205161	CARRINHO-GUIA OS SUPERIOR N°3 UPPER GUIDE ROLLER BEARING N3 ROULEAU-GUIDE SUPÉRIEUR N3	1
205173	ESQUADRO 18-1310-C BLOCKING BRACKET ÉQUERRE	8
213018	CANTO DE ALINHAMENTO OS N.2 ANGLE ANGLE	8
202323	CONTRA-FECHO OS INOX C/ AFINAÇÃO N°2 COUNTER-LOCK BRACKET CONTRE-FERMETURE SUPPORT	3
213220	AMORTECEDOR OS N.3 SHOCK ABSORBER AMORTISSEUR	2
201089	FECHO LATERAL OS N°4 N°4 LATERAL LOCK SERRURE LATÉRALE N°4	1
280000	TESTA OS-D P/FECHO OS N.2 STRIKING PLATE GÂCHE	3
215037	PEÇA AJUSTE P/FECHO LAT OS N.4 ADJUSTMENT PIECE PIÈCE DE RÉGLAGE	4
228166	MOLA PARA RETENÇÃO DE FECHO OS OS LOCK RETAINER SPRING RESSORT DE RETENUE POUR FERMETURE OS	1
210165	TOPO LATERAL SUP/INF N°15 OS-V2 LATERAL UPPER/LOWER N°15 OS-V2 END-CAP EMBOUT LAT SUP/INF N°15 OS-V2	2
210268	GOTEIRA C/ VÁLVULA SVE FLAP VALVE CLAPET À VOILE	DIVERSOS DIVERSES DIVERS
210265	GOTEIRA C/ VÁLVULA BOLA BALL VALVE CLAPET À BILLE	DIVERSOS DIVERSES DIVERS
290020	PARAFUSO PAR 006 SCREW VIS	DIVERSOS DIVERSES DIVERS
215078	PEÇA ANTI-LEVANTAMENTO OS ANTI-LIFT ACCESSORY ANTI-LEVAGE ACCESSOIRE	1
215083	ANTI-LEVANTAMENTO GUIA INOX OS OS GUIDE ANTI-LIFT ACCESSORY ACCESSOIRE ANTI-LEVAGE POUR GUIDE INOX OS	2
215194	CHAPA BLOQUEIO PELÚCIA PILE SEAL LOCK PLATE PLAQUE DE VERROUILLAGE DE JOINT BRUSSE	4
210510	TOPO BLOQUEIO PELÚCIA CV PILE SEAL LOCK END-CAP CV EMBOUT DE VERROUILLAGE DE JOINT BRUSSE CV	4
212245	CONJ. TOPOS CAL./SOL. OS-D 1-RAIL 1-RAIL END-CAP KIT KIT D'EMBOUT DE GOUTTIÈRE/SEUIL OS-D 1-RAIL	1

Na encomenda do vidro, indicar a posição do vidro interior/exterior e esquerda/direita
When placing the order, please mention the position of the glass inside/outside and left/right
A la passation de commande, veuillez indiquer la position du verre intérieure/extérieure et gauche/droite

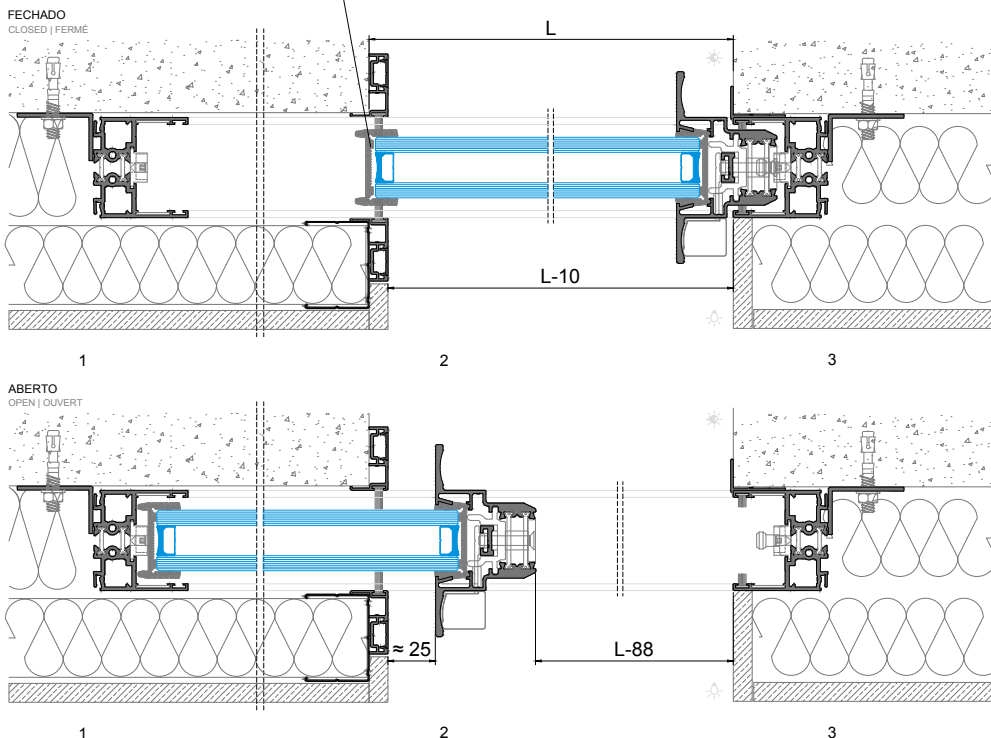

JANELA DE CORRER DE EMBUTIR COM 1 FOLHA
1 SASH POCKET SLIDING WINDOW
FENÊTRE COULISSANT À GALANDAGE 1 VANTAIL

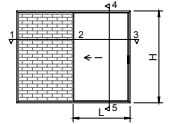

VEDANTES SEALENTS JOINTS		
CODIGO CODE	DESIGNAÇÃO DESIGNATION NOMINATION	QUANTIDADE QUANTITY QUANTITE
208450	PELÚCIA 7x5.5 Cinza PILE SEAL JOINT BRUSSE ou or ou	4I
208465	PELÚCIA 7x5.5 Preta PILE SEAL JOINT BRUSSE	
208460	PELÚCIA 7x7 S-F PILE SEAL JOINT BRUSSE	7H
208897	PELÚCIA SRF 4X8X100 2P1M PILE SEAL JOINT BRUSSE	2un.
208499	VD 2063.N	2H
208193	VD 2060	2L

PERFIS PROFILES PROFILÉS					
CODIGO CODE	DESIGNAÇÃO DESIGNATION NOMINATION	CORTE HORIZ. HORIZONTAL DETAIL DETAIL HORIZONTAL	CORTE VERT. VERTICAL DETAIL DETAIL VERTICAL	QUANT. QUANTITY QUANTITE	CORTE CUT GOÛPE
SO 14	ARO FIXO FIXED FRAME DORMANT	(Lx2)+65	H	2+2	
SO 65	ARO MÓVEL LATERAL MOBILE FR. OUVRANT	-	H-118	1	
SO 30	VARETA ROD PROFILE TIGE	-	VARIÁVEL VARIABLE VARIABLE	1	
OS 11	ARO MÓVEL CENTRAL PROFILE PROFILÉ	-	H-118	1	
OS 801	GUIA INF. INOX LOWER GUIDE GUIDE INFÉRIEUR	(Lx2)+19	-	1	
OS 35	GUIA SUP. UPPER GUIDE GUIDE SUPÉRIEUR	(Lx2)+19	-	1	
SO 45	PERFIL REMATE PROFILE PROFILÉ				
SO 46	PERFIL REMATE PROFILE PROFILÉ				
SO 47	PERFIL REMATE PROFILE PROFILÉ				
SO 48	PERFIL REMATE PROFILE PROFILÉ				
JM 81	PERFIL COMPLEMENTAR COMPLEMENT. PROFILE PROF. COMPLÉMENTAIRE				
KQ 25	PERFIL REMATE PROFILE PROFILÉ				
KP 42	PERFIL REMATE PROFILE PROFILÉ				
SO 80	PERFIL SOLEIRA SILL PROFILE PROFILÉ DE SEUIL				
SO 25	PERFIL CALEIRA DRAINAGE CHANNEL GOUTTIÈRE DE VIDANGE				
SO 58	TAMPA DE CALEIRA DRAINAGE CHANNEL GRID GRILLE POUR GOUTTIÈRE DE VIDANGE				
VO 11	PERFIL FIXAÇÃO TAMPA DRAINAGE (1) CHANNEL GRID FIX. PROF. PROF. FIXATION GRILLE				

CONSULTAR DEPARTAMENTO TÉCNICO
CONSULT TECHNICAL DEPARTMENT
CONSULTER DÉPARTEMENT TECHNIQUE

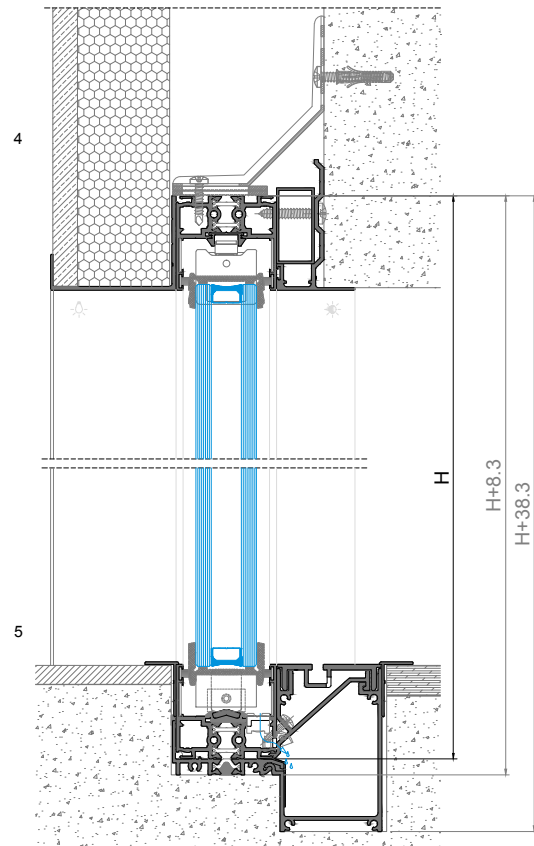

* Opcional | Optional | Optionnel
(1) Peças com 400mm, aplicadas aproximadamente a cada 800mm | Pieces 400mm long, applied approximately every 800mm | Pièces de 400 mm, appliquées à environ tous les 800 mm

ACESSÓRIOS ACCESSORIES ACCESSOIRES		
CODIGO CODE	DESIGNAÇÃO DESIGNATION NOMINATION	QUANTIDADE QUANTITY QUANTITE
205162	CARRINHO OS N°5 ROLLER BEARING ROULEAU	2
205161	CARRINHO-GUIA OS SUPERIOR N°3 UPPER-GUIDE ROLLER BEARING N3 ROULEAU-GUIDE SUPÉRIEUR N3	2
205173	ESQUADRO 18-1310-C BLOCKING BRACKET ÉQUERRE	8
213018	CANTO DE ALINHAMENTO OS N.2 ANGLE ANGLE	8
202323	CONTRA-FECHO OS INOX C/ AFINAÇÃO N°2 COUNTER-LOCK BRACKET CONTRE-FERMETURE SUPPORT	3
213220	AMORTECEDOR OS N.3 SHOCK ABSORBER AMORTISSEUR	2
201089	FECHO LATERAL OS N°4 N°4 LATERAL LOCK SERRURE LATÉRALE N°4	1
280000	TESTA OS-D P/FECHO OS N.2 STRIKING PLATE GÂCHE	3
215037	PEÇA AJUSTE P/FECHO LAT OS N.4 ADJUSTEMENT PIECE PIÈCE DE RÉGLAGE	4
228166	MOLA PARA RETENÇÃO DE FECHO OS OS LOCK RETAINER SPRING RESSORT DE RETENUE POUR FERMETURE OS	1
210094	TOPO CENTRAL N°2 OS-V2 ESQUERDO CENTRAL N°2 LEFT END-CAP EMBOUT CENTRAL N°2 GAUCHE	1
210095	TOPO CENTRAL N°2 OS-V2 DIREITO CENT. N°2 RIGHT END-CAP EMBOUT CENT. N°2 DROITE	1
210165	TOPO LATERAL SUP/INF N°15 OS-V2 LATERAL UPPER/LOWER N°15 OS-V2 END-CAP EMBOUT LAT SUP/INF N°15 OS-V2	2
210268	GOTEIRA C/ VÁLVULA SVE FLAP VALVE CLAPET À VOILET	DIVERSOS DIVERS DIVERS
210265	GOTEIRA C/ VÁLVULA BOLA BALL VALVE CLAPET À BILLE	DIVERSOS DIVERS DIVERS
290020	PARAFUSO PAR 006 SCREW VIS	DIVERSOS DIVERS DIVERS
215078	PEÇA ANTI-LEVANTAMENTO OS ANTI-LIFT ACCESSORY ANTI-LEVAGE ACCESSOIRE	1
215083	ANTI-LEVANTAMENTO GUIA INOX OS OS GUIDE ANTI-LIFT ACCESSORY ACCESSOIRE ANTI-LEVAGE POUR GUIDE INOX OS	2
215194	CHAPA BLOQUEIO PELÚCIA PILE SEAL LOCK PLATE BLOQUE DE VERROUILLAGE DE JOINT BRUSSE	4
210510	TOPO BLOQUEIO PELÚCIA CV PILE SEAL LOCK END-CAP CV EMBOUT DE VERROUILLAGE DE JOINT BRUSSE CV	4
212245	CONJ. TOPOS CAL/SOL OS-D 1-RAIL DRAINAGE CHANNEL/SILL OS-D 1-RAIL END-CAP KIT KIT D'EMBOUT DE GOUTTIÈRE/SEUIL OS-D 1-RAIL	1

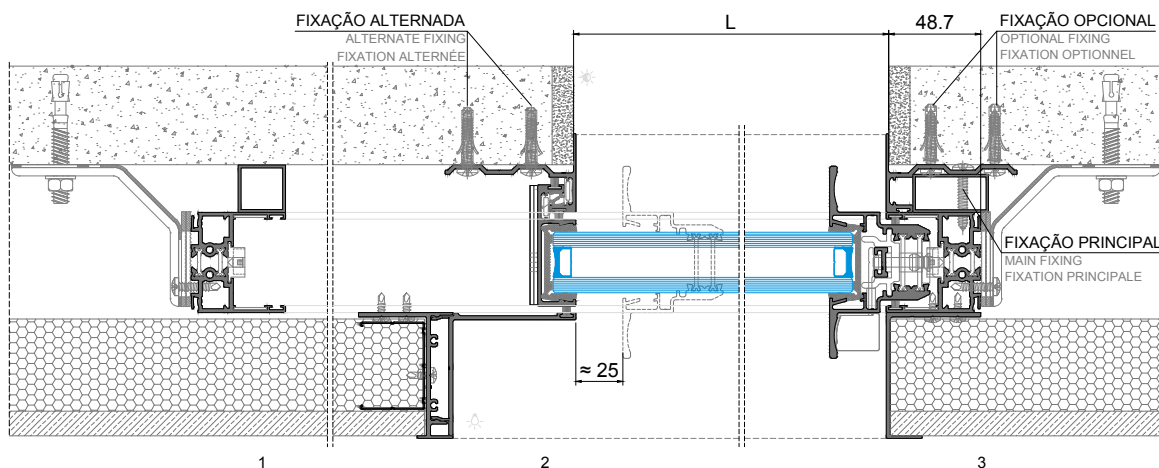

JANELA DE CORRER DE EMBUTIR COM 2 FOLHAS 1-RAIL - COM PERFIS SO 38 + SO 39
2 SASHES 1-RAIL POCKET SLIDING WINDOW - WITH SO 38 + SO 39 PROFILES
FENÊTRE COULISSANT À GALANDAGE 2 VANTAUX 1-RAIL - AVEC PROFILÉS SO 38 + SO 39

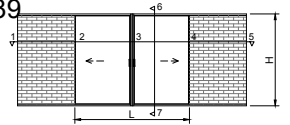

VEDANTES SEALENTS JOINTS		
CODIGO CODE	DESIGNAÇÃO DESIGNATION NOMINATION	QUANTIDADE QUANTITY QUANTITE
208450	PELÚCIA 7x5.5 Cinza PILE SEAL JOINT BRUSSE ou or ou	4L
208465	PELÚCIA 7x5.5 Preta PILE SEAL JOINT BRUSSE	
208460	PELÚCIA 7x7 S-F PILE SEAL JOINT BRUSSE	7H
208450	PELÚCIA 7x5.5 PILE SEAL JOINT BRUSSE (SO 38 SO 39) ou or ou	3H
208465	PELÚCIA 7x5.5 PILE SEAL JOINT BRUSSE (SO 38 SO 39)	
208597	PELÚCIA SRF SRF 4X8X100 2P1M PILE SEAL JOINT BRUSSE	4un.
208499	VD 2063.N	6H
208193	VD 2060	2L
208225	VD 2050	1H

PERFIS PROFILES PROFILÉS					
CODIGO CODE	DESIGNAÇÃO DESIGNATION NOMINATION	CORTE HORIZ. HORIZONTAL DETAIL	CORTE VERT. VERTICAL DETAIL	QUANT. QUANTITY	CORTE CUT
SO 14	ARO FIXO FIXED FRAME DORMANT	(Lx2)+95	H	2+2	
SO 38	PERFIL CENTRAL CONTRA FECHO PROFILE PROFILÉ	-	H-73	1	
SO 39	PERFIL CENTRAL FECHO PROFILE PROFILÉ	-	H-73	1	
SO 33	BARRA DE CREMONE DUPLA DOUBLE CREMONE ROD TIGE CREMONE DOUBLE	-	VARIÁVEL VARIABLE VARIABLE	4	
OS 11	ARO MÓVEL CENTRAL PROFILE PROFILÉ	-	H-118	2	
OS 801	GUIA INF. INOX LOWER GUIDE GUIDE INFÉRIEUR	(Lx2)+49	-	1	
OS 35	GUIA SUP. UPPER GUIDE GUIDE SUPÉRIEUR	(Lx2)+49	-	1	
SO 45	PERFIL REMATE PROFILE PROFILÉ				CONSULTAR DEPARTAMENTO TÉCNICO CONSULT TECHNICAL DEPARTMENT CONSULTER DÉPARTEMENT TECHNIQUE
SO 46	PERFIL REMATE PROFILE PROFILÉ				
SO 47	PERFIL REMATE PROFILE PROFILÉ				
SO 48	PERFIL REMATE PROFILE PROFILÉ				
JM 81	PERFIL COMPLEMENTAR COMPLEMENT PROFILE PROF. COMPLEMENTAIRE *				
KQ 25	PERFIL REMATE PROFILE PROFILÉ				
KP 42	PERFIL REMATE PROFILE PROFILÉ				
SO 80	PERFIL SOLEIRA SILL PROFILE PROFILÉ DE SEUIL				
SO 25	PERFIL CALEIRA DRAINAGE CHANNEL GOUTTIÈRE DE VIDANGE				
SO 58	TAMPA DE CALEIRA DRAINAGE CHANNEL GRID GRILLE POUR GOUTTIÈRE DE VIDANGE				
VO 11	PERFIL FIXAÇÃO TAMPA DRAINAGE (1) CHANNEL GRID FIX. PROF. PROF. FIXATION GRILLE				

* Opcional | Optional | Optionnel
(1) Peças com 400mm, aplicadas aproximadamente a cada 800mm | Pieces 400mm long, applied approximately every 800mm | Pièces de 400 mm, appliquées à environ tous les 800 mm

ACESSÓRIOS ACCESSORIES ACCESSOIRES		
CODIGO CODE	DESIGNAÇÃO DESIGNATION NOMINATION	QUANTIDADE QUANTITY QUANTITE
205162	CARRINHO OS N°5 ROLLER BEARING ROULEAU	4
205161	CARRINHO-GUIA OS SUPERIOR N°3 UPPER-GUIDE ROLLER BEARING N3 ROULEAU-GUIDE SUPÉRIEUR N3	4
205173	ESQUADRO 18-1310-C BLOCKING BRACKET ÉQUERRE	8
213018	CANTO DE ALINHAMENTO OS N.2 ANGLE ANGLE	8
201097	FECHO EMBUTIR OS MONODIR MONODIRECTIONAL RECESSED LOCK SERRURE À ENCASTRER MONODIRECTIONNEL	1
212000	CONJ. FECHO SO38/SO39 LOCK SET KIT FERMETURE *	1
212019	CONJ. TOPOS SO38/SO39 END-CAP KIT KIT D'EMBOUIT	1
290099	PARAFUSO DIN7991 M5x8 INOX A2 SCREW VIS	4
210094	TOPO CENTRAL N°2 OS-V2 ESQUERDO CENTRAL N°2 LEFT END-CAP EMBOUT CENTRAL N°2 GAUCHE	2
210095	TOPO CENTRAL N°2 OS-V2 DIREITO CENT. N°2 RIGHT END-CAP EMBOUT CENT. N°2 DROITE	2
210268	GOTEIRA C/ VÁLVULA SVE DRIP GOUTTIÈRE	DIVERSOS DIVERS DIVERS
210265	GOTEIRA C/ VÁLVULA BOLA BALL VALVE CLAPET À BILLE	DIVERSOS DIVERS DIVERS
290020	PARAFUSO PAR 006 SCREW VIS	DIVERSOS DIVERS DIVERS
215083	ANTI-LEVANTAMENTO GUIA INOX OS OS GUIDE ANTI-LIFT ACCESSORY ACCESSOIRE ANTI-LEVAGE POUR GUIDE INOX OS	2
215194	CHAPA BLOQUEIO PELÚCIA PILE SEAL LOCK PLATE PLAQUE DE VERROUILLAGE DE JOINT BRUSSE	8
212245	CONJ. TOPOS CAL/SOL OS-D 1-RAIL DRAINAGE CHANNEL/SILL OS-D 1-RAIL END-CAP KIT KIT D'EMBOUIT DE GOUTTIÈRE/SEUIL OS-D 1-RAIL	1

* 2Un./prumada para alturas até 3metros. 3Un./prumada para alturas superiores a 3 metros
2units./union for heights up to 3 meters. 3units./union for heights over 3 meters | 2 unités./union pour les hauteurs jusqu'à 3 mètres. 3unités./union pour les hauteurs supérieures à 3 mètres

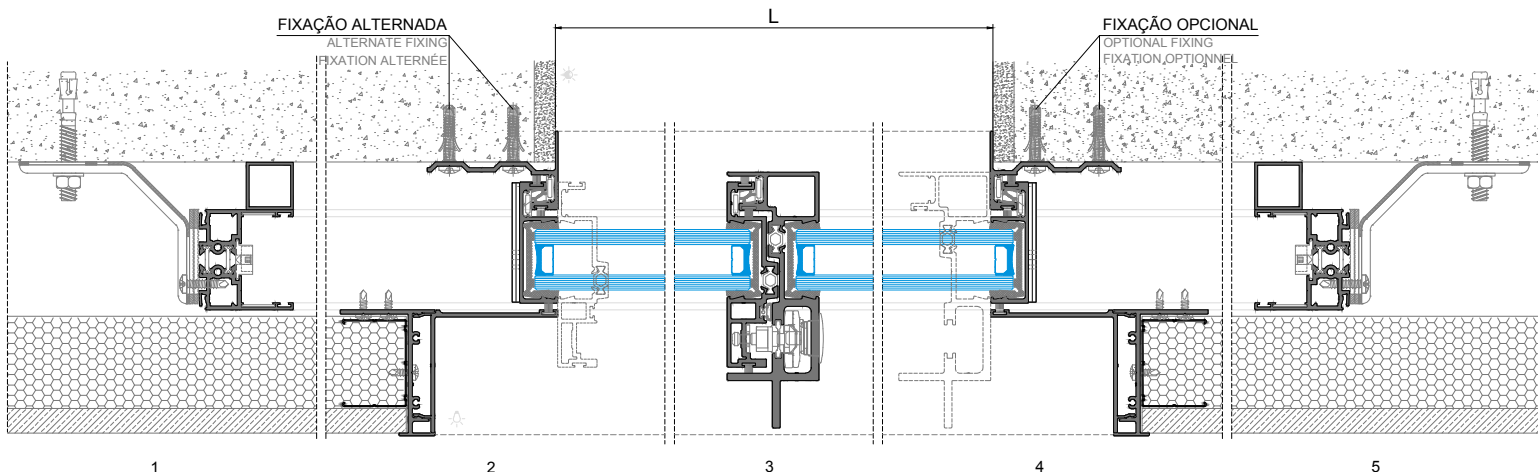
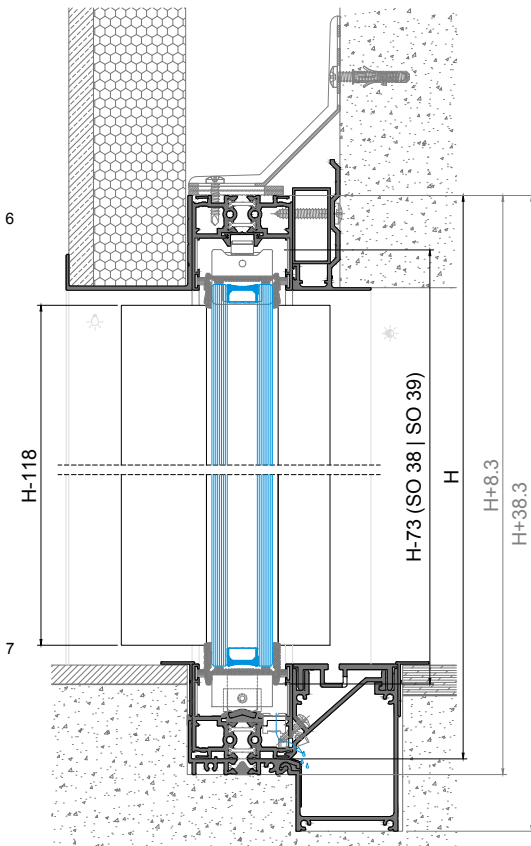

JANELA DE CORRER DE EMBUTIR COM 2 FOLHAS 1-RAIL com OS 27
 2 SASHES 1-RAIL POCKET SLIDING WINDOW with OS 27
 FENÊTRE COULISSANT À GALANDAGE À 2 VANTAOX 1-RAIL avec OS 27

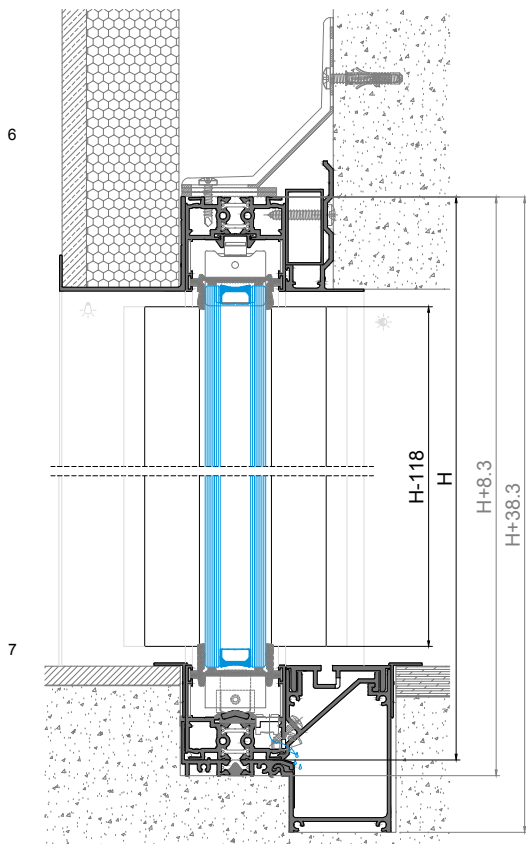
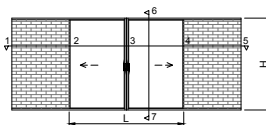

PERFIS PROFILES PROFILÉS					
CÓDIGO CODE	DESIGNAÇÃO DESIGNATION NOMINATION	CORTE HORIZ. HORIZONTAL DETAIL	CORTE VERT. VERTICAL DETAIL	QUANT. QUANTITY	CORTE CUT
SO 14	ARO FIXO FIXED FRAME DORMANT	(Lx2)-2	H	2+2	
SO 30	VARETA ROD PROFILE TIGE	-	VARIÁVEL VARIABLE VARIABLE	1	
OS 27	PERFIL UNIÃO 3/4 F UNION PROFILE PROFILÉ D'UNION	-	H-118	1	
SO 65	ARO MÓVEL LATERAL MOBILE FR. OUVRANT	-	H-118	1	
OS 11	ARO MÓVEL CENTRAL PROFILE PROFILÉ	-	H-118	2	
OS 801	GUIA INF. INOX LOWER GUIDE GUIDE INFÉRIEUR	(Lx2)-48	-	1	
OS 35	GUIA SUP. UPPER GUIDE GUIDE SUPÉRIEUR	(Lx2)-48	-	1	
SO 45	PERFIL REMATE PROFILE PROFILÉ	CONSULTAR DEPARTAMENTO TÉCNICO CONSULT TECHNICAL DEPARTMENT CONSULTER DÉPARTEMENT TECHNIQUE			
SO 46	PERFIL REMATE PROFILE PROFILÉ				
SO 47	PERFIL REMATE PROFILE PROFILÉ				
SO 48	PERFIL REMATE PROFILE PROFILÉ				
JM 81	PERFIL COMPLEMENTAR COMPLEMENT PROFILE PROF. COMPLÉMENTAIRE *				
KQ 25	PERFIL REMATE PROFILE PROFILÉ				
KP 42	PERFIL REMATE PROFILE PROFILÉ				
SO 80	PERFIL SOLEIRA SILL PROFILE PROFILÉ DE SEUIL				
SO 25	PERFIL CALEIRA DRAINAGE CHANNEL GOUTTIÈRE DE VIDANGE				
SO 58	TAMPA DE CALEIRA DRAINAGE CHANNEL GRID GRILLE POUR GOUTTIÈRE DE VIDANGE				
VO 11	PERFIL FIXAÇÃO TAMPA DRAINAGE (1) CHANNEL GRID FIX. PROF. PROF. FIXATION GRILLE				

* Opcional | Optional | Optionnel
 (1) Peças com 400mm, aplicadas aproximadamente a cada 800mm | Pieces 400mm long, applied approximately every 800mm | Pièces de 400 mm, appliquées à environ tous les 800 mm

ACESSÓRIOS ACCESSORIES ACCESSOIRES		
CÓDIGO CODE	DESIGNAÇÃO DESIGNATION NOMINATION	QUANTIDADE QUANTITY QUANTITÉ
205162	CARRINHO OS Nº5 ROLLER BEARING ROULEAU	4
205161	CARRINHO-GUIA OS SUPERIOR Nº3 UPPER-GUIDE ROLLER BEARING N3 ROULEAU-GUIDE SUPERIEUR N3	4
205173	ESQUADRO 18-1310-C BLOCKING BRACKET ÉQUERRE	8
213018	CANTO DE ALINHAMENTO OS N.2 ANGLE ANGLE	8
202323	CONTRA-FECHO OS INOX C/ AFINAÇÃO Nº2 COUNTER-LOCK BRACKET CONTRE-FERMETURE SUPPORT	3
213220	AMORTECEDOR OS N.3 SHOCK ABSORBER AMORTISSEUR	2
201089	FECHO LATERAL OS Nº4 Nº3 LATERAL LOCK SERRURE LATÉRALE Nº3	1
280000	TESTA OS-D P/FECHO OS N.2 STRIKING PLATE GÂCHE	3
215037	PEÇA AJUSTE P/FECHO LAT OS N.4 ADJUSTMENT PIECE PIÈCE DE REGLAGE	4
228166	MOLA PARA RETENÇÃO DE FECHO OS OS LOCK RETAINER SPRING RESSORT DE RETENUE POUR FERMETURE OS	1
210094	TOPO CENTRAL Nº2 OS-V2 ESQUERDO CENTRAL Nº2 LEFT END-CAP EMBOUT CENTRAL Nº2 GAUCHE	2
210095	TOPO CENTRAL Nº2 OS-V2 DIREITO CENT. Nº2 RIGHT END-CAP EMBOUT CENT. Nº2 DROITE	2
210165	TOPO LATERAL SUP/INF Nº15 OS-V2 LATERAL UPPER/LOWER Nº15 OS-V2 END-CAP EMBOUT LAT SUP/INF Nº15 OS-V2	2
212124	CONJ. TOPOS PARA OS 27 END-CAPS EMBOUT	2
210268	GOTEIRA C/ VÁLVULA SVE DRIP GOUTTIÈRE	DIVERSOS DIVERSES DIVERS
210265	GOTEIRA C/ VÁLVULA BOLA BALL VALVE CLAPET À BILLE	DIVERSOS DIVERSES DIVERS
290020	PARAFUSO PAR 006 SCREW VIS	DIVERSOS DIVERSES DIVERS
215078	PEÇA ANTI-LEVANTAMENTO OS ANTI-LIFT ACCESSORY ANTI-LEVAGE ACCESSOIRE	1
215083	ANTI-LEVANTAMENTO GUIA INOX OS OS GUIDE ANTI-LIFT ACCESSORY ACCESSOIRE ANTI-LEVAGE POUR GUIDE INOX OS	2
215194	CHAPA BLOQUEIO PELÚCIA PILE SEAL LOCK PLATE PLAQUE DE VERROUILLAGE DE JOINT BROSSÉ	8
212245	CONJ. TOPOS CAL./SOL. OS-D 1-RAIL DRAINAGE CHANNEL/SILL OS-D 1-RAIL END-CAP KIT KIT D'EMBOUT DE GOUTTIÈRE/SEUIL OS-D 1-RAIL	1

VEDANTES SEALENTS JOINTS		
CÓDIGO CODE	DESIGNAÇÃO DESIGNATION NOMINATION	QUANTIDADE QUANTITY QUANTITÉ
208450 ou or ou	PELÚCIA 7x5.5 Cinza PILE SEAL JOINT BROSSÉ	4L
208465	PELÚCIA 7x5.5 Preta PILE SEAL JOINT BROSSÉ	4L
208460	PELÚCIA 7x7 S-F PILE SEAL JOINT BROSSÉ	8H
208597	PELÚCIA SRF SRF 4X8X100 2P1M PILE SEAL JOINT BROSSÉ	4un.
208499	VD 2063.N	4H
208193	VD 2060	2L

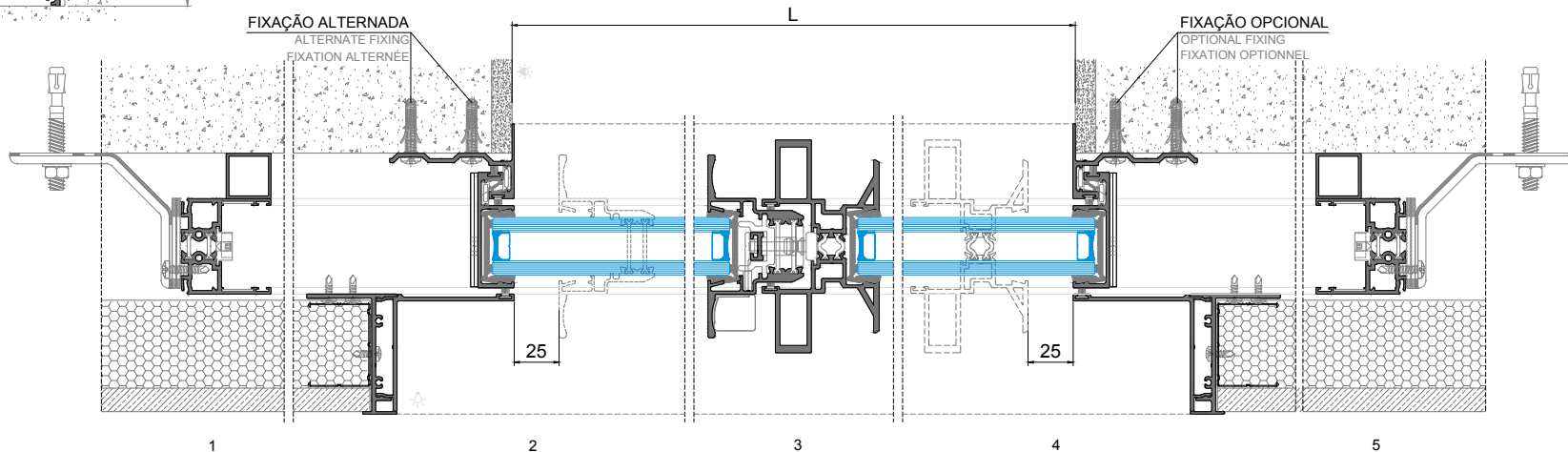

JANELA DE CORRER DE EMBUTIR COM 1 FOLHA 2-RAIL
1 SASH 2-RAIL POCKET SLIDING WINDOW
FENÊTRE COULISSANT À GALANDAGE 1 VANTAIL 2-RAIL

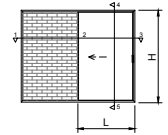

PERFIS PROFILES PROFILÉS					
CODIGO CODE	DESIGNAÇÃO DESIGNATION NOMINATION	CORTE HORIZ. HORIZONTAL DETAIL	CORTE VERT. VERTICAL DETAIL	QUANT. CUT QUANTITE	CORTE CUT COUPE
SO 11	ARO FIXO FIXED FRAME DORMANT				
OS 11	ARO MÓVEL CENTRAL PROFILE PROFILÉ				
SO 65	ARO MÓVEL LATERAL MOBILE FR. OUVRIANT				
SO 30	VARETA ROD PROFILE TIGE				
SO 60	TAMPA DE CANAL TRACK COVER PROFILÉ CACHE CANAL				
OS 801	GUIA INF. INOX LOWER GUIDE GUIDE INFÉRIEUR				
OS 35	GUIA SUP. UPPER GUIDE GUIDE SUPÉRIEUR				
OS 95	POLIAMIDA POLYAMIDE POLYAMIDE				
OS 30	PERFIL REMATE PROFILE PROFILÉ				
SO 45	PERFIL REMATE PROFILE PROFILÉ				
SO 46	PERFIL REMATE PROFILE PROFILÉ				
SO 47	PERFIL REMATE PROFILE PROFILÉ				
SO 48	PERFIL REMATE PROFILE PROFILÉ				
JM 81	PERFIL COMPLEMENTAR COMPLEMENT PROFILE PROF. COMPLÉMENTAIRE *				
KQ 25	PERFIL REMATE PROFILE PROFILÉ				
KP 42	PERFIL REMATE PROFILE PROFILÉ				
SO 82	PERFIL SOLEIRA SILL PROFILE PROFILÉ DE SEUIL				
SO 25	PERFIL CALEIRA DRAINAGE CHANNEL GOUTTIÈRE DE VIDANGE				
SO 58	TAMPA DE CALEIRA DRAINAGE CHANNEL GRID GRILLE POUR GOUTTIÈRE DE VIDANGE				
VO 11	PERFIL FIXAÇÃO TAMPA DRAINAGE CHANNEL GRID FIX. PROF. PROF. FIXATION GRILLE				

CONSULTAR DEPARTAMENTO TÉCNICO
CONSULT TECHNICAL DEPARTMENT
CONSULTER DÉPARTEMENT TECHNIQUE

* Opcional | Optional | Optionnel
(1) Peças com 400mm, aplicadas aproximadamente a cada 800mm | Pieces 400mm long, applied approximately every 800mm | Pièces de 400 mm, appliquées à environ tous les 800 mm

ACESSÓRIOS ACCESSORIES ACCESSOIRES		
CODIGO CODE	DESIGNAÇÃO DESIGNATION NOMINATION	QUANTIDADE QUANTITY QUANTITE
205162	CARRINHO OS Nº5 ROLLER BEARING ROULEAU	2
205161	CARRINHO-GUIA OS SUPERIOR Nº3 UPPER-GUIDE ROLLER BEARING N3 ROULEAU-GUIDE SUPÉRIEUR N3	2
205172	ESQUADRO 18-2210-D BLOCKING BRACKET ÉQUERRE	8
213018	CANTO DE ALINHAMENTO OS N.2 ANGLE ANGLE	8
202323	CONTRA-FECHO OS INOX C/ AFINAÇÃO Nº2 COUNTER-LOCK BRACKET CONTRE-FERMETURE SUPPORT	3
213220	AMORTECEDOR OS N.3 SHOCK ABSORBER AMORTISSEUR	2
280000	TESTA OS-D P/FECHO OS N.2 STRIKING PLATE GÂCHE	3
201089	FECHO LATERAL OS Nº4 Nº4 LATERAL LOCK SERRURE LATÉRALE Nº4	1
215037	PEÇA AJUSTE P/FECHO LAT OS N.4 ADJUSTMENT PIECE PIÈCE DE REGIAGE	4
228186	MOLA PARA RETENÇÃO DE FECHO OS OS LOCK RETAINER SPRING RESSORT DE RETENIEUR POUR FERMETURE OS	1
210094	TOPO CENTRAL Nº2 OS-V2 ESQUERDO CENTRAL Nº2 LEFT END-CAP EMBOUT CENTRAL Nº2 GAUCHE	2
210095	TOPO CENTRAL Nº2 OS-V2 DIREITO CENT. Nº2 RIGHT END-CAP EMBOUT CENT. Nº2 DROITE	2
210165	TOPO LATERAL SUP/INF Nº15 OS-V2 LAT. UPPER/LOWER Nº15 OS-V2 END-CAP EMBOUT LAT SUP/INF Nº15 OS-V2	2
213273	CORTA-VENTO OS SUPERIOR UPPER CENTRAL GASKET PIÈCE D'ÉTANCHÉITE SUPÉRIEUR	1
213274	CORTA-VENTO OS INFERIOR LOWER CENTRAL GASKET PIÈCE D'ÉTANCHÉITE INFÉRIEUR	1
210288	GOTEIRA C/ VÁLVULA SVE FLAP VALVE CLAPET À VOLET	DIVERSOS DIVERSES DIVERS
210265	GOTEIRA C/ VÁLVULA BOLA BALL VALVE CLAPET À BILLE	DIVERSOS DIVERSES DIVERS
290020	PARAFUSO PAR 006 SCREW VIS	DIVERSOS DIVERSES DIVERS
215078	PEÇA ANTI-LEVANTAMENTO OS ANTI-LIFT ACCESSORY ANTI-LEVAGE ACCESSOIRE	1
215083	ANTI-LEVANTAMENTO GUIA INOX OS OS GUIDE ANTI-LIFT ACCESSORY ACCESSOIRE ANTI-LEVAGE POUR GUIDE INOX OS	2
215194	CHAPA BLOQUEIO PELÚCIA PILE SEAL LOCK PLATE PLAQUE DE VERROUILLAGE DE JOINT BROSSE	2
210510	TOPO BLOQUEIO PELÚCIA CV PILE SEAL LOCK END-CAP CV EMBOUT DE VERROUILLAGE DE JOINT BROSSE CV	2
212246	CONJ. TOPOS CAL./SOL. OS-D 2-RAIL DRAINAGE CHANNEL/SILL OS-D 2-RAIL END-CAP KIT KIT D'EMBOUT DE GOUTTIÈRE/SEUIL OS-D 2-RAIL	1

VEDANTES SEALENTS JOINTS		
CODIGO CODE	DESIGNAÇÃO DESIGNATION NOMINATION	QUANTIDADE QUANTITY QUANTITE
208450 ou de 180	PELÚCIA 7x5.5 Cinza PILE SEAL JOINT BROSSE ou or ou	8L
208465	PELÚCIA 7x5.5 Preta PILE SEAL JOINT BROSSE	8L
208460	PELÚCIA 7x7 S-F PILE SEAL JOINT BROSSE	7H
208597	PELÚCIA SRF SRF 4X8X100 2P1M PILE SEAL JOINT BROSSE	4un.
208499	VD 2063.N	2H
208193	VD 2060	2L

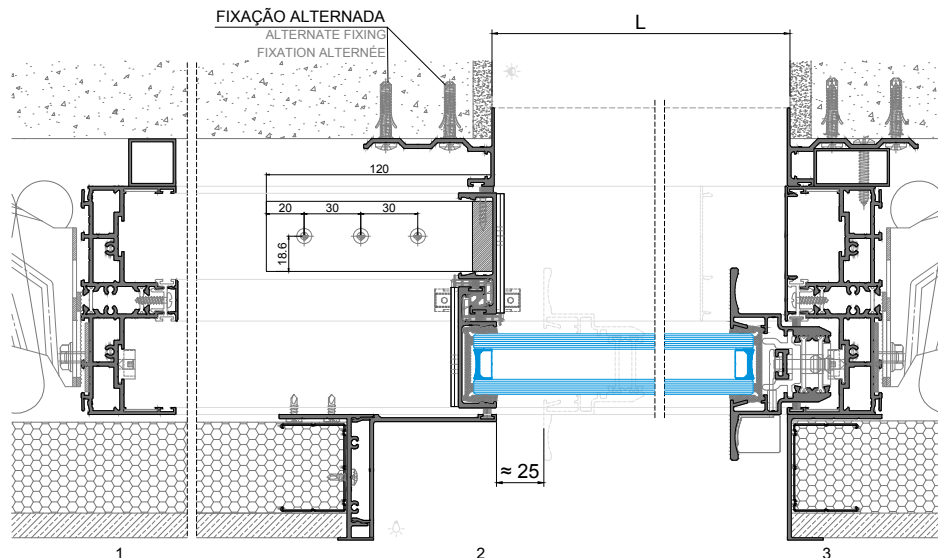
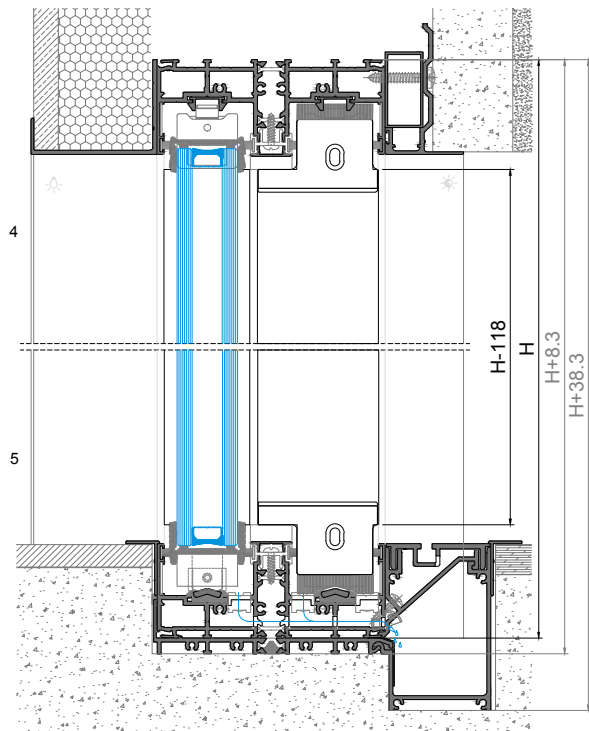

JANELA DE CORRER DE EMBUTIR COM 2 FOLHAS 2-RAIL
2 SASHES 2-RAIL POCKET SLIDING WINDOW
FENÊTRE COULISSANT À GALANDAGE 2 VANTAUX 2-RAIL

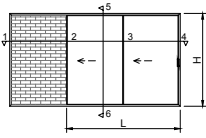

VEDANTES SEALENTS JOINTS		
CÓDIGO CODE	DESIGNAÇÃO DESIGNATION NOMINATION	QUANTIDADE QUANTITY QUANTITÉ
208450 ou or ou 208465	PELÚCIA 7x5.5 Cinza PILE SEAL JOINT BRASSE ou or ou PELÚCIA 7x5.5 Preta PILE SEAL JOINT BRASSE	8L
208460	PELÚCIA 7x7 S-F PILE SEAL JOINT BRASSE	7H
208597	PELÚCIA SRF SRF 4X8X100 2P1M PILE SEAL JOINT BRASSE	8un.
208499	VD 2063.N	4H
208193	VD 2060	4L

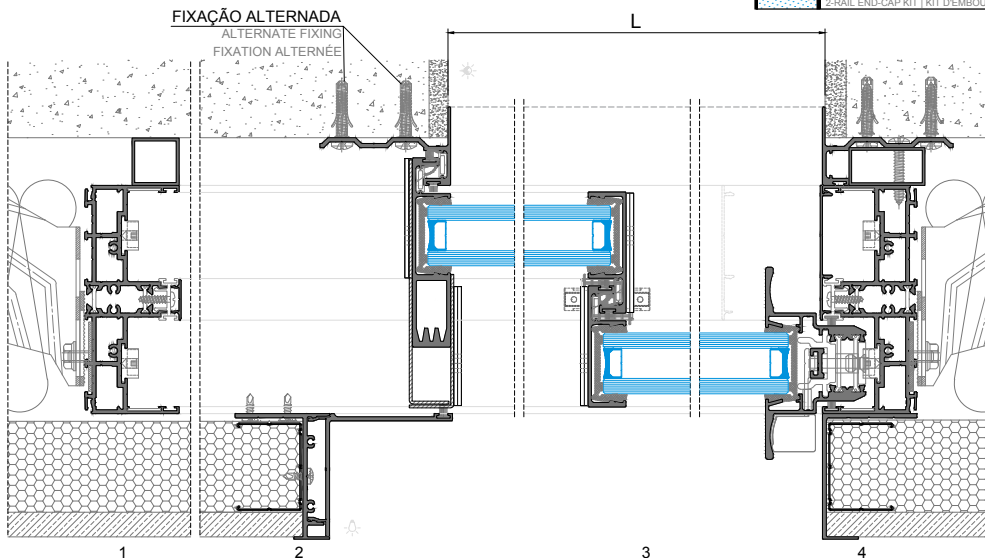
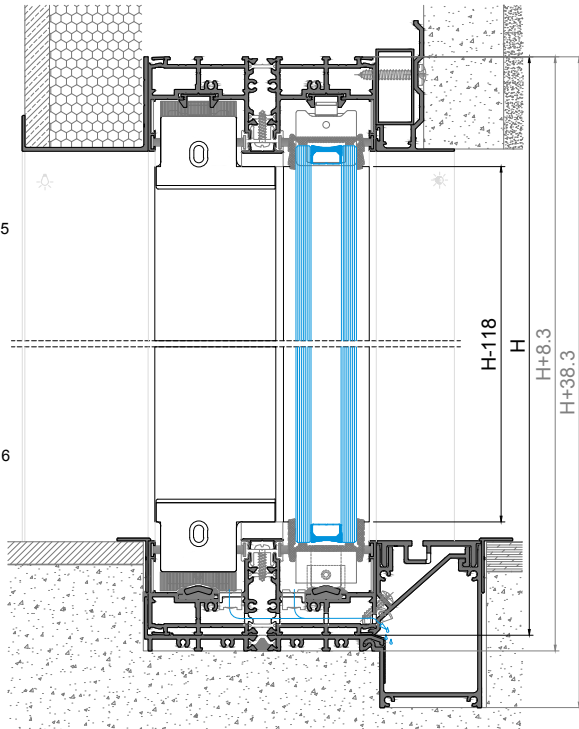

PERFIS PROFILES PROFILÉS					
CÓDIGO CODE	DESIGNAÇÃO DESIGNATION NOMINATION	CORTE HORIZ. HORIZONTAL DETAIL	CORTE VERT. VERTICAL DETAIL	QUANT. QUANTITY	CORTE CUT
SO 11	ARO FIXO FIXED FRAME DORMANT				
OS 11	ARO MÓVEL CENTRAL PROFILE PROFILÉ				
OS 61	ARO MÓVEL CENTRAL PROFILE PROFILÉ				
SO 65	ARO MÓVEL LATERAL MOBILE FR. OUVRANT				
SO 30	VARETA ROD PROFILE TIGE				
SO 60	TAMPA DE CANAL TRACK COVER PROFILE CACHE CANAL				
OS 801	GUIA INF. INOX LOWER GUIDE GUIDE INFÉRIEUR				
OS 35	GUIA SUP. UPPER GUIDE GUIDE SUPÉRIEUR				
OS 95	POLIAMIDA POLYAMIDE POLYAMIDE				
SO 30	PERFIL REMATE PROFILE PROFILÉ				
SO 45	PERFIL REMATE PROFILE PROFILÉ				
SO 46	PERFIL REMATE PROFILE PROFILÉ				
SO 47	PERFIL REMATE PROFILE PROFILÉ				
SO 48	PERFIL REMATE PROFILE PROFILÉ				
JM 81	PERFIL COMPLEMENTAR COMPLEMENT. PROFILE PROF. COMPLEMENTAIRE				*
KQ 25	PERFIL REMATE PROFILE PROFILÉ				
KP 42	PERFIL REMATE PROFILE PROFILÉ				
SO 82	PERFIL SOLEIRA SILL PROFILE PROFILÉ DE SEUIL				
SO 25	PERFIL CALEIRA DRAINAGE CHANNEL GOUTTIERE DE VIDANGE				
SO 58	TAMPA DE CALEIRA DRAINAGE CHANNEL GRID GRILLE POUR GOUTTIERE DE VIDANGE				
VO 11	PERFIL FIXAÇÃO TAMPA DRAINAGE CHANNEL GRID FIX. PROF. PROF. FIXATION GRILLE				(1)

CONSULTAR DEPARTAMENTO TÉCNICO
CONSULT TECHNICAL DEPARTMENT
CONSULTER DÉPARTEMENT TECHNIQUE

* Opcional | Optional | Optionnel/OPTIONAL | OPTIONNEL
(1) Peças com 400mm, aplicadas aproximadamente a cada 800mm | Pieces 400mm long, applied approximately every 800mm | Pièces de 400 mm, appliquées à environ tous les 800 mm

ACESSÓRIOS ACCESSORIES ACCESSOIRES		
CÓDIGO CODE	DESIGNAÇÃO DESIGNATION NOMINATION	QUANTIDADE QUANTITY QUANTITÉ
205162	CARRINHO OS N°5 ROLLER BEARING ROULEAU	4
205161	CARRINHO-GUIA OS SUPERIOR N°3 GUIDE-ROLLER BEARING N3 ROULEAU-GUIDE SUPÉRIEUR N3	4
205172	ESQUADRO 18-2210-D BLOCKING BRACKET ÉQUERRE	8
213018	CANTO DE ALINHAMENTO OS N.2 ANGLE ANGLE	8
202323	CONTRA-FECHO OS INOX C/ AFINAÇÃO N°2 COUNTER-LOCK BRACKET CONTRE-FERMETURE SUPPORT	3
213220	AMORTECEDOR OS N.3 SHOCK ABSORBER AMORTISSEUR	2
280000	TESTA OS-D P/FECHO OS N.2 STRIKING PLATE GÂCHE	3
201089	FECHO LATERAL OS N°4 N°4 LATERAL LOCK SERRURE LATÉRALE N°4	1
215037	PEÇA AJUSTE P/FECHO LAT OS N.4 ADJUSTMENT PIECE PIÈCE DE REGLAGE	4
228166	MOLA PARA RETENÇÃO DE FECHO OS OS LOCK-RETAIN SPRING RESORT DE RETENUE POUR FERMETURE OS	1
210094	TOPO CENTRAL N°2 OS-V2 ESQUERDO CENTRAL N°2 LEFT END-CAP EMBOUT CENTRAL N°2 GAUCHE	4
210095	TOPO CENTRAL N°2 OS-V2 DIREITO CENT. N°2 RIGHT END-CAP EMBOUT CENT. N°2 DROITE	4
210165	TOPO LATERAL SUP/INF N°15 OS-V2 LATERAL UPPER/LOWER N°15 OS-V2 END-CAP EMBOUT LAT SUP/INF N°15 OS-V2	2
213273	CORTA-VENTO OS SUPERIOR UPPER CENTRAL GASKET PIÈCE D'ÉTANCHÉITE SUPÉRIEUR	1
213274	CORTA-VENTO OS INFERIOR LOWER CENTRAL GASKET PIÈCE D'ÉTANCHÉITE INFÉRIEUR	1
210268	GOTEIRA C/ VÁLVULA SVE FLAP VALVE CLAPET À VOILE	DIVERSOS DIVERSES DIVERS
210265	GOTEIRA C/ VÁLVULA BOLA BALL VALVE CLAPET À BILLE	DIVERSOS DIVERSES DIVERS
290020	PARAFUSO PAR 006 SCREW VIS	DIVERSOS DIVERSES DIVERS
212066	CONJUNTO TOPOS OS 61 OS 61 END-CAP KIT KIT D'EMBOUT OS 61	1
215078	PEÇA ANTI-LEVANTAMENTO OS ANTI-ACCESSORY ANTI-LIFT ACCESSOIRE	1
215083	ANTI-LEVANTAMENTO GUIA INOX OS OS GUIDE ANTI-LIFT ACCESSORY ACCESSOIRE ANTI-LEVAGE POUR GUIDE INOX OS	4
215194	CHAPA BLOQUEIO PELÚCIA PILE SEAL LOCK PLATE PLAQUE DE VERROUILLAGE DE JOINT BRASSE	4
210510	TOPO BLOQUEIO PELÚCIA CV PILE SEAL LOCK END-CAP CV CHARGE DE VERROUILLAGE DE JOINT BRASSE CV	4
212246	CONJ. TOPOS CAL./SOL. OS-D 2-RAIL DRAINAGE CHANNEL/SILL OS-D 2-RAIL END-CAP KIT KIT D'EMBOUT DE GOUTTIERE/SEUIL OS-D 2-RAIL	1

JANELA DE CORRER 2 FOLHAS - COM 2 FECHADURAS
2 SASHES SLIDING WINDOW - WITH 2 LOCKS
FENÊTRE COULISSANT 2 VANTAOX - AVEC 2 SERRURES

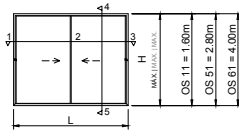

PERFIS PROFILES PROFILÉS					
CÓDIGO CODE	DESIGNAÇÃO DESIGNATION NOMINATION	CORTE HORIZ. HORIZONTAL DETAIL DÉTAIL HORIZONTAL	CORTE VERT. VERTICAL DETAIL DÉTAIL VERTICALE	QUANT. QUANTITY QUANTITÉ	CORTE CUT COUPE
OS 11	ARO FIXO FIXED FRAME DORMANT	L	H	2+2	
OS 11 ou OS 51 ou OS 61	ARO MÓVEL CENTRAL PROFILE PROFILÉ	-	H-118	2	
OS 40	PERFIL TESTA FECHADURA LOCK PLATE PROFILE PROFILÉ POUR SERRURE	-	H-46	2	
OS 60	TAMPA DE CANAL TRACK COVER PROFILÉ CACHE CANAL	-	H-46	2	
OS 03	ARO MÓVEL LATERALP/ FECHADURA LATERAL LOCK PROFILE OUVRANT LAT. SERRURE	-	H-118	2	
OS 35	GUIA SUP. UPPER GUIDE GUIDE SUPÉRIEUR	L-46	-	2	
OS 801	GUIA INF. INOX LOWER GUIDE GUIDE INFÉRIEUR	L-46	-	2	
OS 95	POLIAMIDA POLYAMIDE POLYAMIDE	(L/2)-50	H-74	4+2	
OS 30	PERFIL REMATE PROFILE PROFILÉ	(L/2)-65	-	4	
OS 82	PERFIL SOLEIRA SILL PROFILE PROFILÉ DE SEUIL	CONSULTAR DEPARTAMENTO TÉCNICO CONSULT TECHNICAL DEPARTMENT CONSULTER DÉPARTEMENT TECHNIQUE			
OS 25	PERFIL CALEIRA DRAINAGE CHANNEL GOUTTIÈRE DE VIDANGE				
OS 58	TAMPA DE CALEIRA DRAINAGE CHANNEL GRID GRILLE POUR GOUTTIÈRE DE VIDANGE				
VO 11	PERFIL FIXAÇÃO TAMPA CHANNEL GRID FIX. PROF. PROF. FIXATION GRILLE				

(1) Peças com 400mm, aplicadas aproximadamente a cada 800mm | Pieces 400mm long, applied approximately every 800mm | Pièces de 400 mm, appliquées à environ tous les 800 mm

VEDANTES SEALENTS JOINTS		
CÓDIGO CODE	DESIGNAÇÃO DESIGNATION NOMINATION	QUANTIDADE QUANTITY QUANTITÉ
208450 ou 19104 208465	PELÚCIA 7x5.5 Cinza PILE SEAL JOINT BROSSE	8L
208460	PELÚCIA 7x5.5 Preta PILE SEAL JOINT BROSSE	6H
208597	PELÚCIA 7x7 S-F PILE SEAL JOINT BROSSE	4un.
208499	PELÚCIA SRF 4X8X100 2P1M PILE SEAL JOINT BROSSE	2H
208193	VD 2060	2L
208193	JUNTA DE ESTANQUIDADE 2050 JOINT JOINT	4H

ACESSÓRIOS ACCESSORIES ACCESSOIRES		
CÓDIGO CODE	DESIGNAÇÃO DESIGNATION NOMINATION	QUANTIDADE QUANTITY QUANTITÉ
205162	CARRINHO OS Nº5 ROLLER BEARING ROULEAU	4
205161	CARRINHO-GUIA OS SUPERIOR Nº3 UPPER-GUIDE ROLLER BEARING Nº3 ROULEAU-GUIDE SUPÉRIEUR Nº3	4
205172	ESQUADRO 18-2210-D BLOCKING BRACKET ÉQUERRE	8
213018	CANTO DE ALINHAMENTO OS N.2 ANGLE ANGLE	8
	FECHADURA 3 PONTOS LOCK SERRURE	* 2
213220	AMORTECEDOR OS N.3 SHOCK ABSORBER AMORTISSEUR	4
280037	TESTA FECHADURA OS-D N.2 STRIKING PLATE GÂCHE	6
290105	PARAFUSO DIN7982 8x3/4 INOX A2 SCREW VIS	12
203306	COPO PARA TESTA FECHADURA RECESSED LOCK END-CAP EMBOUT A ENCASTRER POUR SERRURE	6
	CILINDRO CYLINDER CYLINDRE	* 2
220196	ESPELHO 23MM CYLINDER CYLINDRE	4
210094	TOPO CENTRAL Nº2 OS-V2 ESQUERDO CENTRAL Nº2 LEFT END-CAP EMBOUT CENTRAL Nº2 GAUCHE	2
210095	TOPO CENTRAL Nº2 OS-V2 DIREITO CENT. Nº2 RIGHT END-CAP EMBOUT CENT. Nº2 DROITE	2
210193	TOPO LATERAL SUP/INF Nº21 OS-D FECH. LAT. UPPER/LOWER Nº21 OS-D END-CAP EMBOUT LAT SUP/INF Nº21 OS-D	4
213273	CORTA-VENTO OS SUPERIOR UPPER CENTRAL GASKET PIÈCE D'ÉTANCHEÏTE SUPÉRIEUR	1
213274	CORTA-VENTO OS INFERIOR LOWER CENTRAL GASKET PIÈCE D'ÉTANCHEÏTE INFÉRIEUR	1
212065	CONJUNTO TOPOS OS 51 OS 51 END-CAP KIT KIT D'EMBOUT OS 51	** 2
212066	CONJUNTO TOPOS OS 61 OS 61 END-CAP KIT KIT D'EMBOUT OS 61	** 2
210268	GOTEIRA C/ VÁLVULA SVE FLAP VALVE CLAPET À VOLET	DIVERSOS DIVERSES DIVERS
210265	GOTEIRA C/ VÁLVULA BOLA BALL VALVE CLAPET À BILLE	DIVERSOS DIVERSES DIVERS
290020	PARAFUSO PAR 006 SCREW VIS	DIVERSOS DIVERSES DIVERS
215078	PEÇA ANTI-LEVANTAMENTO OS ANTI-LIFT ACCESSORY ANTI-LEVEAGE ACCESSOIRE	2
215083	OS GUIDE ANTI-LEVE ACCESSORY ACCESSOIRE ANTI-LEVAGE POUR GUIDE INOX OS	4
215194	CHAPA BLOQUEIO PELÚCIA PILE SEAL LOCK PLATE PLAQUE DE VERROUILLAGE DE JOINT BROSSE	4
210510	TOPO BLOQUEIO PELÚCIA CV PILE SEAL LOCK END-CAP CV EMBOUT DE VERROUILLAGE DE JOINT BROSSE CV	4
212246	CONJ. TOPOS CAL/SOL OS-D 2-RAIL DRAINAGE CHANNEL/SILL OS-D 2-RAIL END-CAP KIT KIT D'EMBOUT DE GOUTTIÈRE/SEUIL OS-D 2-RAIL	1

* Consultar lista de acessórios | Consult list of accessories | Consulter la liste des accessoires
** Opcional | Optional | Optionnel

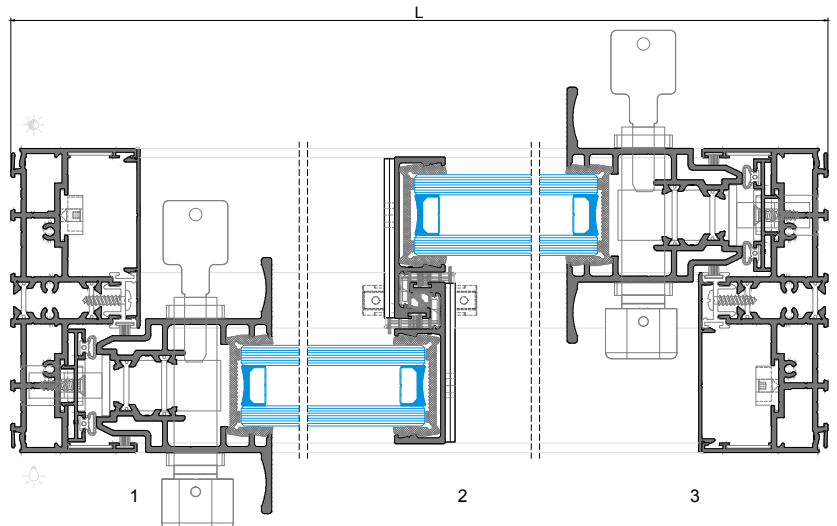
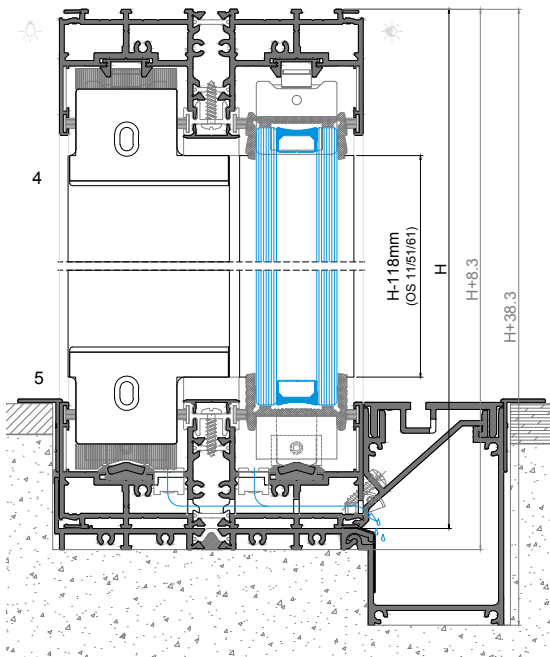

JANELA DE CORRER 2 FOLHAS - COM 1 FECHADURA E 1 FECHO LATERAL - (vidros iguais)
2 SASHES SLIDING WINDOW - WITH 1 LOCK AND 1 LATERAL LOCK - (glasses with equal widths)
FENÊTRE COULISSANT 2 VANTAUX - AVEC 1 SERRURE ET 1 SERRURE LATÉRAL - (verres de même largeurs)

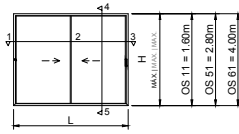

PERFIS PROFILES PROFILÉS					
CÓDIGO CODE	DESIGNAÇÃO DESIGNATION NOMINATION	CORTE HORIZ. HORIZONT. DETAIL	CORTE VERT. VERTICAL DETAIL	QUANT. QUANTITY	CORTE CUT
SO 11	ARO FIXO FIXED FRAME DORMANT	L	H	2+2	
OS 11 ou 111 ou OS 51 ou 101 ou OS 61	ARO MÓVEL CENTRAL PROFILE PROFILÉ	-	H-118	2	
SO 40	PERFIL TESTA FECHADURA LOCK PLATE PROFILE PROFILE POUR SERRURE	-	H-46	2	
SO 60	TAMPA DE CANAL TRACK COVER PROFILE CACHE CANAL	-	H-46	2	
SO 03	ARO MÓVEL LATERALP/ FECHADURA LATERAL LOCK PROFILE OUVRIANT LAT. SERRURE	-	H-118	1	
SO 65	ARO MÓVEL LATERAL MOBILE FR. OUVRIANT	-	H-118	1	
SO 30	VARETA ROD PROFILE TIGE	-	VARIÁVEL VARIABLE VARIABLE	1	
OS 35	GUIA SUP. UPPER GUIDE GUIDE SUPÉRIEUR	L-46	-	2	
OS 801	GUIA INF. INOX LOWER GUIDE GUIDE INFÉRIEUR	L-46	-	2	
OS 95	POLIAMIDA POLYAMIDE POLYAMIDE	(L/2)-50	H-74	4+2	
OS 30	PERFIL REMATE PROFILE PROFILÉ	(L/2)-65	-	4	
SO 82	PERFIL SOLEIRA SILL PROFILE PROFILÉ DE SEUIL	CONSULTAR DEPARTAMENTO TÉCNICO CONSULT TECHNICAL DEPARTMENT CONSULTER DÉPARTEMENT TECHNIQUE			
SO 25	PERFIL CALEIRA DRAINAGE CHANNEL GOUTTIÈRE DE VIDANGE				
SO 58	TAMPA DE CALEIRA DRAINAGE CHANNEL GRID GRILLE POUR GOUTTIÈRE DE VIDANGE				
VO 11	PERFIL FIXAÇÃO TAMPA DRAINAGE (1) CHANNEL GRID FIX. PROF. PROF. FIXATION GRILLE				

(1) Peças com 400mm, aplicadas aproximadamente a cada 800mm | Pieces 400mm long, applied approximately every 800mm | Pièces de 400 mm, appliquées à environ tous les 800 mm

VEDANTES SEALENTS JOINTS		
CÓDIGO CODE	DESIGNAÇÃO DESIGNATION NOMINATION	QUANTIDADE QUANTITY QUANTITÉ
208450 ou 101 ou 208465	PELÚCIA 7x5.5 Cinza PILE SEAL JOINT BROSSÉ ou or ou	8L
208465	PELÚCIA 7x5.5 Preta PILE SEAL JOINT BROSSÉ	8L
208460	PELÚCIA 7x7 S-F PILE SEAL JOINT BROSSÉ	6H
208597	PELÚCIA SRF SRF 4X8X100 2P1M PILE SEAL JOINT BROSSÉ	4un.
208499	VD 2063.N	2H
208193	VD 2060	2L
208193	JUNTA DE ESTANQUIDADE 2050 JOINT JOINT	2H

ACESSÓRIOS ACCESSORIES ACCESSOIRES		
CÓDIGO CODE	DESIGNAÇÃO DESIGNATION NOMINATION	QUANTIDADE QUANTITY QUANTITÉ
205162	CARRINHO OS N°5 ROLLER BEARING ROULEAU	4
205161	CARRINHO-GUIA OS SUPERIOR N°3 UPPER-GUIDE ROLLER BEARING N3 ROULEAU-GUIDE SUPÉRIEUR N3	4
205172	ESQUADRO 18-2210-D BLOCKING BRACKET ÉQUERRE	8
213018	CANTO DE ALINHAMENTO OS N.2 ANGLE ANGLE	8
	FECHADURA 3 PONTOS LOCK SERRURE	*
213220	AMORTECEDOR OS N.3 SHOCK ABSORBER AMORTISSEUR	4
280037	TESTA FECHADURA OS-D N.2 STRIKING PLATE GÂCHE	3
290105	PARAFUSO DIN7982 8x3/4 INOX A2 SCREW VIS	6
203306	COPO PARA TESTA FECHADURA RECESSED LOCK END-CAP EMBOUT A ENCASTRER POUR SERRURE	3
	CILINDRO CYLINDER CYLINDRE	*
220196	ESPELHO 23MM CYLINDER CYLINDRE	2
201089	FECHO LATERAL OS N°4 N°4 LATERAL LOCK SERRURE LATÉRALE N°4	1
228167	MOLA P/ RETENÇÃO FECHO OS N°2 OS LOCK RETAINER SPRING RESSORT DE RETENUE POUR FERMETURE OS	1
215037	PEÇA AJUSTE P/FECHO LAT OS N.4 ADJUSTEMENT PIECE PIECE DE REGLAGE	4
202323	CONTRA-FECHO OS INOX C/ AFINAÇÃO N°2 COUNTER-LOCK BRACKET CONTRE-FERMETURE SUPPORT	3
280000	TESTA OS-D P/FECHO OS N.2 STRIKING PLATE GÂCHE	3
210094	TOPO CENTRAL N°2 OS-V2 ESQUERDO CENTRAL N°2 LEFT END-CAP EMBOUT CENTRAL N°2 GAUCHE	2
210095	TOPO CENTRAL N°2 OS-V2 DIREITO CENT. N°2 RIGHT END-CAP EMBOUT CENT. N°2 DROITE	2
210193	TOPO LATERAL SUP/INF N°21 OS-D FECH. LAT. UPPER/LOWER N°21 OS-D END-CAP EMBOUT LAT SUP/INF N°21 OS-D	2
210165	TOPO LATERAL SUP/INF N°15 OS-V2 LAT. UPPER/LOWER N°15 OS-V2 END-CAP EMBOUT LAT SUP/INF N°15 OS-V2	2
213273	CORTA-VENTO OS SUPERIOR UPPER CENTRAL GASKET PIÈCE D'ÉTANCHÉITE SUPÉRIEUR	1
213274	CORTA-VENTO OS INFERIOR LOWER CENTRAL GASKET PIÈCE D'ÉTANCHÉITE INFÉRIEUR	1
212065	CONJUNTO TOPOS OS 51 OS 51 END-CAP KIT KIT D'EMBOUT OS 51	**
212066	CONJUNTO TOPOS OS 61 OS 61 END-CAP KIT KIT D'EMBOUT OS 61	**
210268	GOTEIRA C/ VÁLVULA SVE FLAP VALVE CLAPET À VOILET	DIVERSOS DIVERSES DIVERS
210265	GOTEIRA C/ VÁLVULA BOLA BALL VALVE CLAPET À BILLE	DIVERSOS DIVERSES DIVERS
290020	PARAFUSO PAR 006 SCREW VIS	DIVERSOS DIVERSES DIVERS
215078	PEÇA ANTI-LEVANTAMENTO OS ANTI-LIFT ACCESSORY ANTI-LEVERAGE ACCESSOIRE	2
215083	ANTI-LEVANTAMENTO GUIA INOX OS OS GUIDE ANTI-LIFT ACCESSORY ACCESSOIRE ANTI-LEVERAGE POUR GUIDE INOX OS	4
215194	CHAPA BLOQUEIO PELÚCIA PILE SEAL LOCK PLATE PLAQUE DE VERROUILLAGE DE JOINT BROSSÉ	4
210510	TOPO BLOQUEIO PELÚCIA CV PILE SEAL LOCK END-CAP CV EMBOUT DE VERROUILLAGE DE JOINT BROSSÉ CV	4
212246	CONJ. TOPOS CAL/SOL OS-D 2-RAIL DRAINAGE CHANNEL/SILL OS-D 2-RAIL END-CAP KIT KIT D'EMBOUT DE GOUTTIÈRE/SEUIL OS-D 2-RAIL	1

* Consultar lista de acessórios | Consult list of accessories | Consulter la liste des accessoires
 ** Opcional | Optional | Optionnel

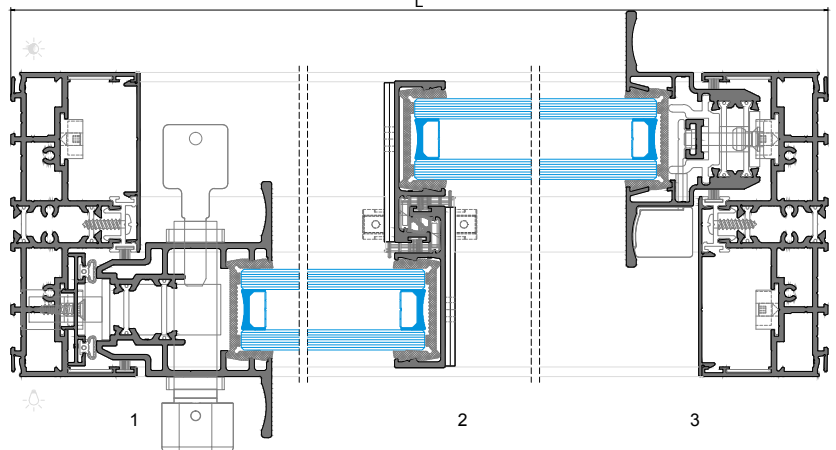
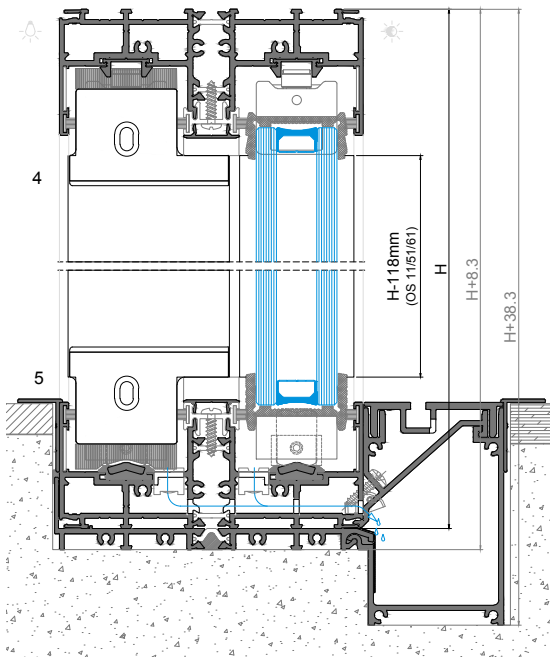

JANELA DE CORRER 3 FOLHAS - COM 2 FECHADURAS
3 SASHES SLIDING WINDOW - WITH 2 LOCKS
FENÊTRE COULISSANT 3 VANTAOX - AVEC 2 SERRURES

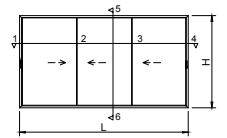

PERFIS PROFILES PROFILÉS					
CODIGO CODE	DESIGNAÇÃO DESIGNATION NOMINATION	CORTE HORIZ. HORIZONTAL DETAIL	CORTE VERT. VERTICAL DETAIL	QUANT. QUANTITY	CORTE CUT
SO 12	ARO FIXO FIXED FRAME DORMANT	L	H	2+2	
OS 61	ARO MÓVEL CENTRAL PROFILE PROFILÉ	-	H-118	4	
SO 40	PERFIL TESTA FECHADURA LOCK PLATE PROFILE PROFILÉ POUR SERRURE	-	H-46	2	
SO 61	TAMPA DE CANAL TRACK COVER PROFILÉ CACHE-CANAL	-	H-46	2	
OS 03	ARO MÓVEL LATERALP/ FECHADURA LATERAL LOCK PROFILE LOUVRANT LAT. SERRURE	-	H-118	2	
OS 35	GUIA SUP. UPPER GUIDE GUIDE SUPÉRIEUR	L-46	-	3	
OS 801	GUIA INF. INOX LOWER GUIDE GUIDE INFÉRIEUR	L-46	-	3	
OS 95	POLIAMIDA POLYAMIDE POLYAMIDE	(L/3)-26.5 ((L/3)-36.5)x2	H-74	4+4 4	
OS 30	PERFIL REMATE PROFILE PROFILÉ	-	-	4	
SO 84	PERFIL SOLEIRA SILL PROFILE PROFILÉ DE SEUIL	CONSULTAR DEPARTAMENTO TÉCNICO CONSULT TECHNICAL DEPARTMENT CONSULTER DÉPARTEMENT TECHNIQUE			
SO 25	PERFIL CALEIRA DRAINAGE CHANNEL GOUTTIÈRE DE VIDANGE				
SO 58	TAMPA DE CALEIRA DRAINAGE CHANNEL GRID GRILLE POUR GOUTTIÈRE DE VIDANGE				
VO 11	PERFIL FIXAÇÃO TAMPA DRAINAGE (1) CHANNEL GRID FIX. PROF. PROF. FIXATION GRILLE				

(1) Peças com 400mm, aplicadas aproximadamente a cada 800mm | Pieces 400mm long, applied approximately every 800mm | Pièces de 400 mm, appliquées à environ tous les 800 mm

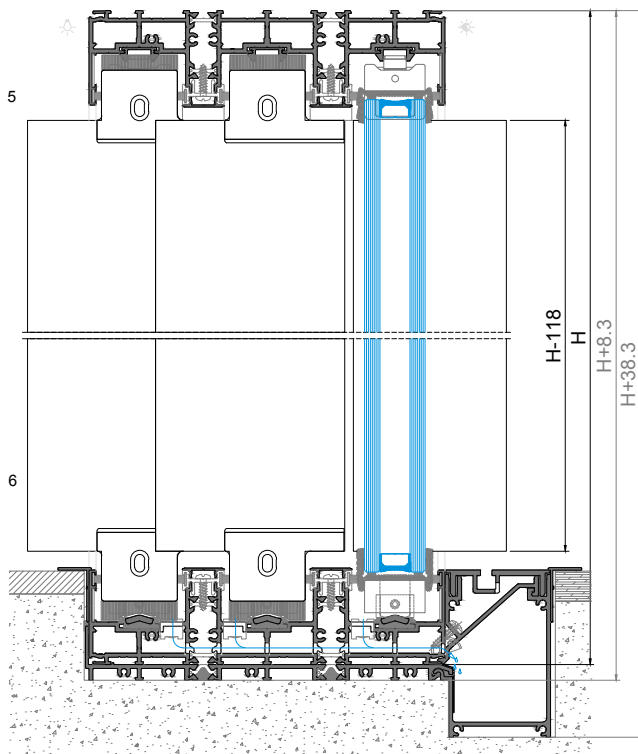

ACESSÓRIOS ACCESSORIES ACCESSOIRES		
CODIGO CODE	DESIGNAÇÃO DESIGNATION NOMINATION	QUANTIDADE QUANTITY QUANTITÉ
205162	CARRINHO OS Nº5 ROLLER BEARING ROULEAU	6
205161	CARRINHO-GUIA OS SUPERIOR Nº3 UPPER-GUIDE ROLLER BEARING N3 ROULEAU-GUIDE SUPÉRIEUR N3	6
205172	ESQUADRO 18-2210-D BLOCKING BRACKET ÉQUERRE	16
213018	CANTO DE ALINHAMENTO OS N.2 ANGLE ANGLE	8
	FECHADURA 3 PONTOS LOCK SERRURE	2 *
213220	AMORTECEDOR OS N.3 SHOCK ABSORBER AMORTISSEUR	4
280037	TESTA FECHADURA OS-D N.2 STRIKING PLATE GÂCHE	6
290105	PARAFUSO DIN7982 8x3/4 INOX A2 SCREW VIS	12
203306	COPO PARA TESTA FECHADURA RECESSED LOCK END-CAP EMBOUT A ENCASTRER POUR SERRURE	6
	CILINDRO CYLINDER CYLINDRE	2 *
220196	ESPELHO 23MM CYLINDER CYLINDRE	4
210094	TOPO CENTRAL Nº2 OS-V2 ESQUERDO CENTRAL Nº2 LEFT END-CAP EMBOUT CENTRAL Nº2 GAUCHE	4
210095	TOPO CENTRAL Nº2 OS-V2 DIREITO CENT. Nº2 RIGHT END-CAP EMBOUT CENT. Nº2 DROITE	4
210193	TOPO LATERAL SUP/INF Nº21 OS-D FECH. LAT. UPPER/LOWER Nº21 OS-D END-CAP EMBOUT LAT SUP/INF Nº21 OS-D	4
213273	CORTA-VENTO OS SUPERIOR UPPER CENTRAL GASKET PIÈCE D'ÉTANCHÉITE SUPÉRIEUR	2
213274	CORTA-VENTO OS INFERIOR LOWER CENTRAL GASKET PIÈCE D'ÉTANCHÉITE INFÉRIEUR	2
	CONJUNTO TOPOS OS 61 OS 61 END-CAP KIT KIT D'EMBOUT OS 61	4 **
210266	GOTEIRA C/ VÁLVULA SVE FLAP VALVE CLAPET À VOLET	DIVERSOS DIVERSES DIVERS
210265	GOTEIRA C/ VÁLVULA BOLA BALL VALVE CLAPET À BILLE	DIVERSOS DIVERSES DIVERS
290020	PARAFUSO PAR 006 SCREW VIS	DIVERSOS DIVERSES DIVERS
215078	PEÇA ANTI-LEVANTAMENTO OS ANTI-LIFT ACCESSORY ANTI-LEVAGE ACCESSOIRE	2
215083	ANTI-LEVANTAMENTO GUIA INOX OS OS GUIDE ANTI-LIFT ACCESSORY ACCESSOIRE ANTI-LEVAGE POUR GUIDE INOX OS	6
215194	CHAPA BLOQUEIO PELÚCIA PILE SEAL LOCK PLATE PLAQUE DE VERROUILLAGE DE JOINT BROSSÉ	8
210510	TOPO BLOQUEIO PELÚCIA CV PILE SEAL LOCK END-CAP CV EMBOUT DE VERROUILLAGE DE JOINT BROSSÉ CV	8
212246	CONJ. TOPOS CAL/SOL OS-D 2-RAIL DRAINAGE CHANNEL/SILL OS-D 2-RAIL END-CAP KIT KIT D'EMBOUT DE GOUTTIÈRE/SEUIL OS-D 2-RAIL	1

* Consultar lista de acessórios | Consult list of accessories | Consulter la liste des accessoires
** Opcional | Optional | Optionnel

VEDANTES SEALENTS JOINTS		
CODIGO CODE	DESIGNAÇÃO DESIGNATION NOMINATION	QUANTIDADE QUANTITY QUANTITÉ
208450 ou or ou	PELÚCIA 7x5.5 Cinza PILE SEAL JOINT BROSSÉ	12L
208465	PELÚCIA 7x5.5 Preta PILE SEAL JOINT BROSSÉ	
208460	PELÚCIA 7x7 S-F PILE SEAL JOINT BROSSÉ	8H
208597	PELÚCIA SRF SRF 4X8X100 2P1M PILE SEAL JOINT BROSSÉ	8un.
208499	VD 2063.N	4H
208193	VD 2060	3L
208193	JUNTA DE ESTANQUIDADE 2050 JOINT JOINT	4H

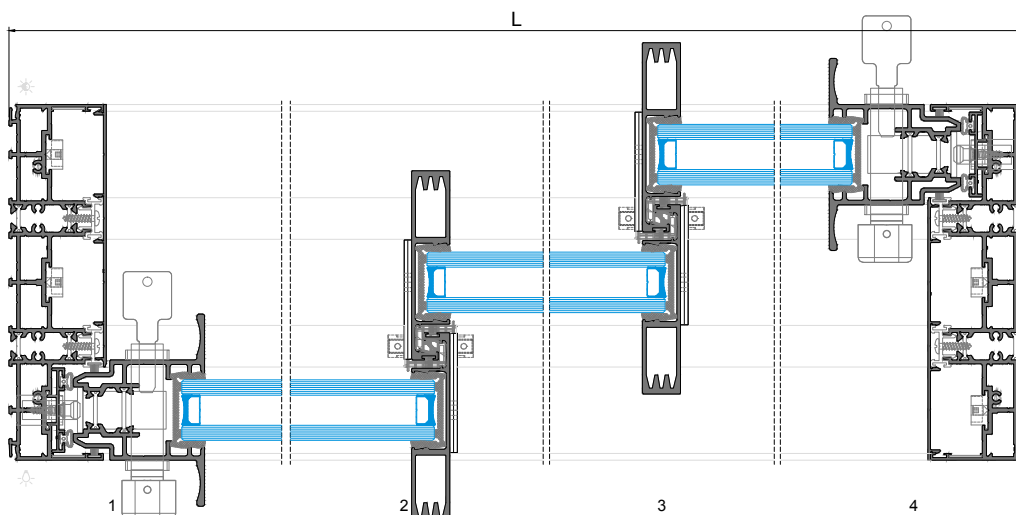

JANELA DE CORRER 3 FOLHAS - COM 1 FECHADURA E 1 FECHO LATERAL - (vidros iguais)
3 SASHES SLIDING WINDOW - WITH 1 LOCK AND 1 LATERAL LOCK - (glasses with equal widths)
FENÊTRE COULISSANT 3 VANTAOX - AVEC 1 SERRURE ET 1 SERRURE LATÉRAL - (verres de même largeurs)

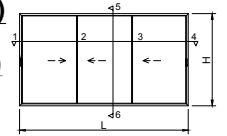

PERFIS PROFILES PROFILÉS					
CÓDIGO CODE	DESIGNAÇÃO DESIGNATION NOMINATION	CORTE HORIZ. HORIZONTAL DETAIL	CORTE VERT. VERTICAL DETAIL	QUANT. QUANTITY	CORTE CUT
OS 12	ARO FIXO FIXED FRAME DORMANT	L	H	2+2	
OS 61	ARO MÓVEL CENTRAL PROFILE PROFILE	-	H-118	4	
SO 40	PERFIL TESTA FECHADURA LOCK PLATE PROFILE PROFILE POUR SERRURE	-	H-46	2	
SO 61	TAMPA DE CANAL TRACK COVER PROFILÉ CACHE-CANAL	-	H-46	2	
SO 03	ARO MÓVEL LATERAL P/ FECHADURA LATERAL LOCK PROFILE OUVRANT LAT. SERRURE	-	H-118	2	
SO 65	ARO MÓVEL LATERAL MOBILE FR. OUVRANT	-	H-118	1	
SO 30	VARETA ROD PROFILE TIGE	-	VARIÁVEL VARIABLE VARIABLE	1	
OS 35	GUIA SUP. UPPER GUIDE GUIDE SUPÉRIEUR	L-46	-	3	
OS 801	GUIA INF. INOX LOWER GUIDE GUIDE INFÉRIEUR	L-46	-	3	
OS 95	POLIAMIDA POLYAMIDE POLYAMIDE	(L/3)-26.5 (L/3)-36.5x2	H-74	4+4	
OS 30	PERFIL REMATE PROFILE PROFILE	(L/3)-44x2 (L/3)-42	-	4	
SO 84	PERFIL SOLEIRA SILL PROFILE PROFILÉ DE SEUIL	CONSULTAR DEPARTAMENTO TÉCNICO CONSULT TECHNICAL DEPARTMENT CONSULTER DÉPARTEMENT TECHNIQUE			
SO 25	PERFIL CALEIRA DRAINAGE CHANNEL GOUTTIERE DE VIDANGE				
SO 58	TAMPA DE CALEIRA DRAINAGE CHANNEL GRID GRILLE POUR GOUTTIERE DE VIDANGE				
VO 11	PERFIL FIXAÇÃO TAMPA DRAINAGE CHANNEL GRID FIX. PROF. PROF. FIXATION GRILLE (1)				

(1) Peças com 400mm, aplicadas aproximadamente a cada 800mm | Pieces 400mm long, applied approximately every 800mm | Pièces de 400 mm, appliquées à environ tous les 800 mm

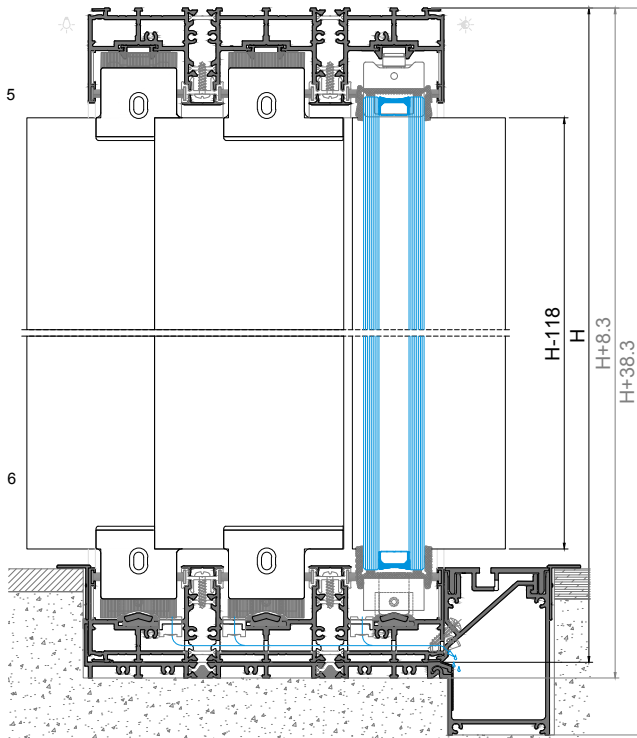

ACESSÓRIOS ACCESSORIES ACCESSOIRES		
CÓDIGO CODE	DESIGNAÇÃO DESIGNATION NOMINATION	QUANTIDADE QUANTITY QUANTITÉ
205162	CARRINHO OS Nº5 ROLLER BEARING ROULEAU	6
205161	CARRINHO-GUIA OS SUPERIOR Nº3 UPPER-GUIDE ROLLER BEARING N3 ROULEAU-GUIDE SUPÉRIEUR N3	6
205172	ESQUADRO 18-2210-D BLOCKING BRACKET ÉQUERRE	16
213018	CANTO DE ALINHAMENTO OS N.2 ANGLE ANGLE	8
	FECHADURA 3 PONTOS LOCK SERRURE	*
213220	AMORTECEDOR OS N.3 SHOCK ABSORBER AMORTISSEUR	4
280037	TESTA FECHADURA OS-D N.2 STRIKING PLATE GÂCHE	3
290105	PARAFUSO DIN7982 8x3/4 INOX A2 SCREW VIS	6
203306	COPO PARA TESTA FECHADURA RECESSED LOCK END-CAP EMBOUT À ENCASTRER POUR SERRURE	3
	CILINDRO CYLINDER CYLINDRE	*
220196	ESPELHO 23MM CYLINDER CYLINDRE	2
201089	FECHO LATERAL OS Nº4 N°4 LATERAL LOCK SERRURE LATÉRALE Nº4	1
228167	MOLA P/ RETENÇÃO FECHO OS Nº2 OS LOCK RETAINER SPRING RESSORT DE RETENUE POUR FERMETURE OS	1
215037	PEÇA AJUSTE P/ FECHO LAT OS N.4 ADJUSTMENT PIECE PIECE DE REGLAGE	4
202323	CONTRA-FECHO OS INOX C/ AFINAÇÃO Nº2 COUNTER-LOCK BRACKET CONTRE-FERMETURE SUPPORT	3
280000	TESTA OS-D P/ FECHO OS N.2 STRIKING PLATE GÂCHE	3
210094	TOPO CENTRAL Nº2 OS-V2 ESQUERDO CENT. Nº2 LEFT END-CAP EMBOUT CENTRAL Nº2 GAUCHE	4
210095	TOPO CENTRAL Nº2 OS-V2 DIREITO CENT. Nº2 RIGHT END-CAP EMBOUT CENT. Nº2 DROITE	4
210193	TOPO LATERAL SUP/INF Nº21 OS-D FECH. LAT. UPPER/LOWER Nº21 OS-D END-CAP EMBOUT LAT SUP/INF Nº21 OS-D	4
210165	TOPO LATERAL SUP/INF Nº15 OS-V2 LAT. UPPER/LOWER Nº15 OS-V2 END-CAP EMBOUT LAT SUP/INF Nº15 OS-V2	2
213273	CORTA-VENTO OS SUPERIOR UPPER CENTRAL GASKET PIÈCE D'ÉTANCHEÏTE SUPÉRIEUR	2
213274	CORTA-VENTO OS INFERIOR LOWER CENTRAL GASKET PIÈCE D'ÉTANCHEÏTE INFÉRIEUR	2
212066	CONJUNTO TOPOS OS 61 OS 61 END-CAP KIT KIT D'EMBOUT OS 61	**
210268	GOTEIRA C/ VÁLVULA SVE FLAP VALVE CLAPET À VOLET	DIVERSOS DIVERS DIVERS
210265	GOTEIRA C/ VÁLVULA BOLA BALL VALVE CLAPET À BILLE	DIVERSOS DIVERS DIVERS
290020	PARAFUSO PAR 006 SCREW VIS	DIVERSOS DIVERS DIVERS
215078	PEÇA ANTI-LEVANTAMENTO OS ANTI-LIFT ACCESSORY ANTI-LEVAGE ACCESSOIRE	2
215083	ANTI-LEVANTAMENTO GUIA INOX OS OS GUIDE ANTI-LIFT ACCESSORY ACCESSOIRE ANTI-LEVAGE POUR GUIDE INOX OS	6
215194	CHAPA BLOQUEIO PELÚCIA PILE SEAL LOCK PLATE PLAQUE DE VERROUILLAGE DE JOINT BROSSÉ	8
210510	TOPO BLOQUEIO PELÚCIA CV1 PILE SEAL LOCK END-CAP CV EMBOUT DE VERROUILLAGE DE JOINT BROSSÉ CV	8
212246	CONJ. TOPOS CAL/SOL OS-D 2-RAIL 2-RAIL END-CAP KIT KIT D'EMBOUT DE GOUTTIERE/SEUIL OS-D 2-RAIL	1

* Consultar lista de acessórios | Consult list of accessories | Consulter la liste des accessoires
** Opcional | Optional | Optionnel

VEDANTES SEALENTS JOINTS		
CÓDIGO CODE	DESIGNAÇÃO DESIGNATION NOMINATION	QUANTIDADE QUANTITY QUANTITÉ
208450 ou 198194	PELÚCIA 7x5.5 Cinza PILE SEAL JOINT BROSSÉ	12L
208465	PELÚCIA 7x5.5 Preta PILE SEAL JOINT BROSSÉ	
208460	PELÚCIA 7x7 S-F PILE SEAL JOINT BROSSÉ	8H
208597	PELÚCIA SRF SRF 4X8X100 2P1M PILE SEAL JOINT BROSSÉ	8un.
208499	VD 2063.N	4H
208193	VD 2060	3L
208193	JUNTA DE ESTANQUIDADE 2050 JOINT JOINT	2H

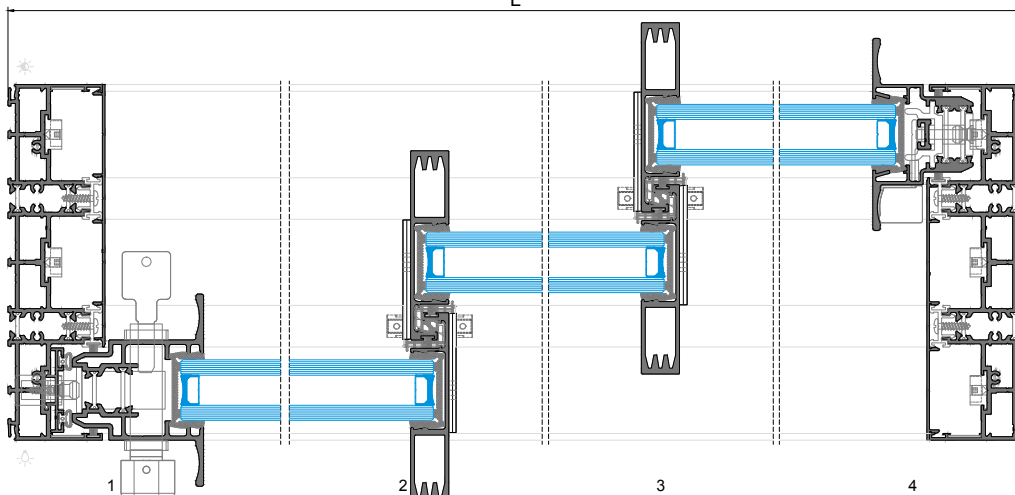

JANELA DE CORRER 4 FOLHAS
COM PERFIS CENTRAIS OS 61 | OS 67
4 SASHES SLIDING WINDOW
WITH CENTRAL PROFILES OS 61 | OS67
FENÊTRE COULISSANT 4 VANTAUX

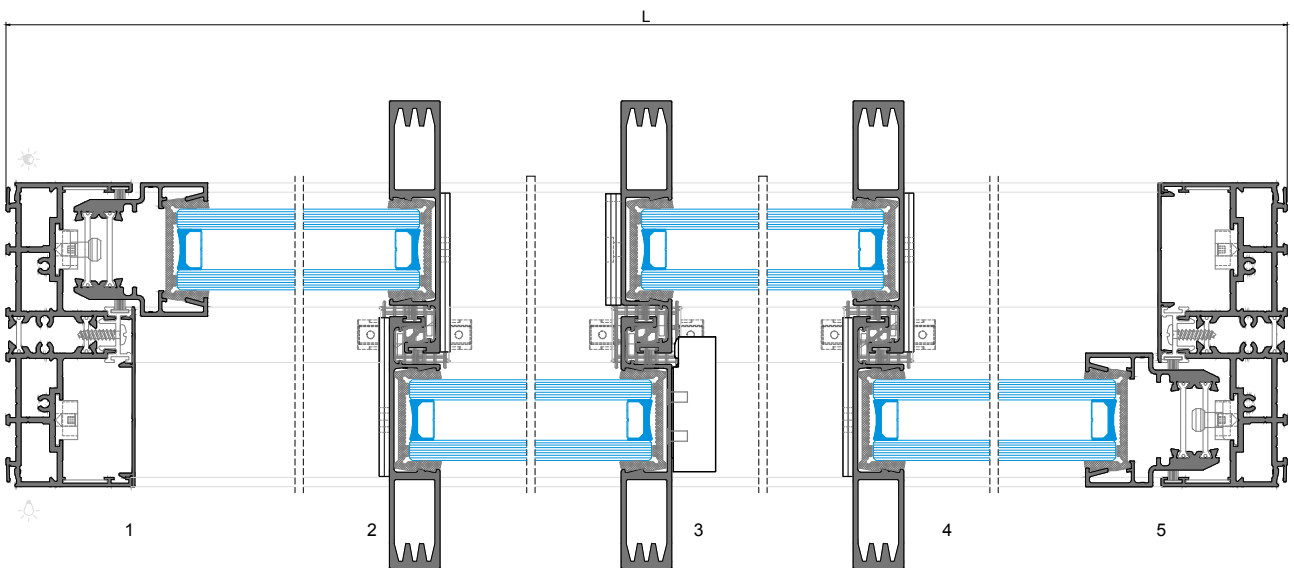
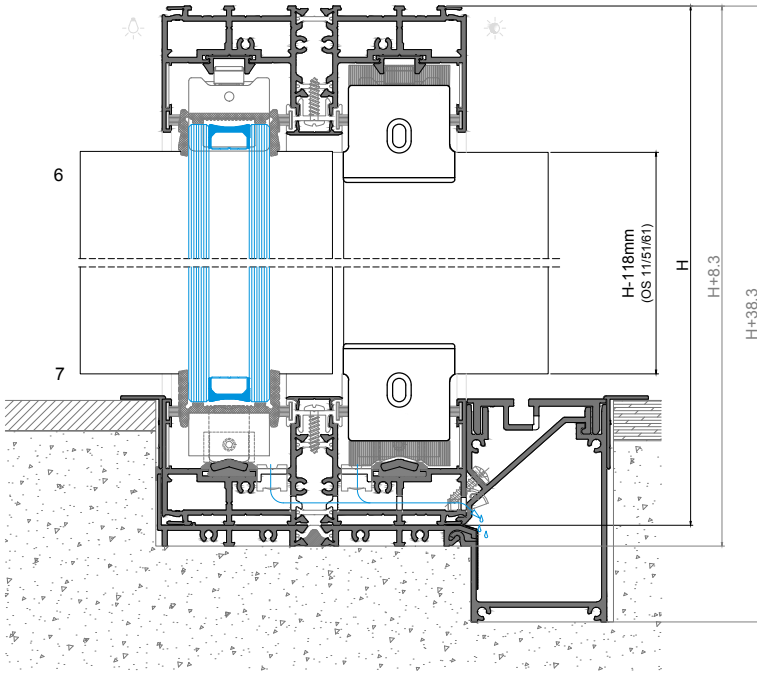
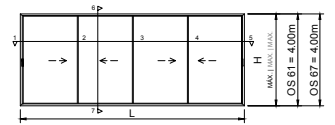

JANELA DE CORRER 2 FOLHAS COM APLICAÇÃO DE REDE MOSQUITEIRA PELO EXTERIOR
2 SASHES SLIDING WINDOW WITH OUTER MOSQUITO NET
FENÊTRE COULISSANT 2 VANTAUX AVEC MOUSTIQUAIRE PAR L'EXTÉRIEUR

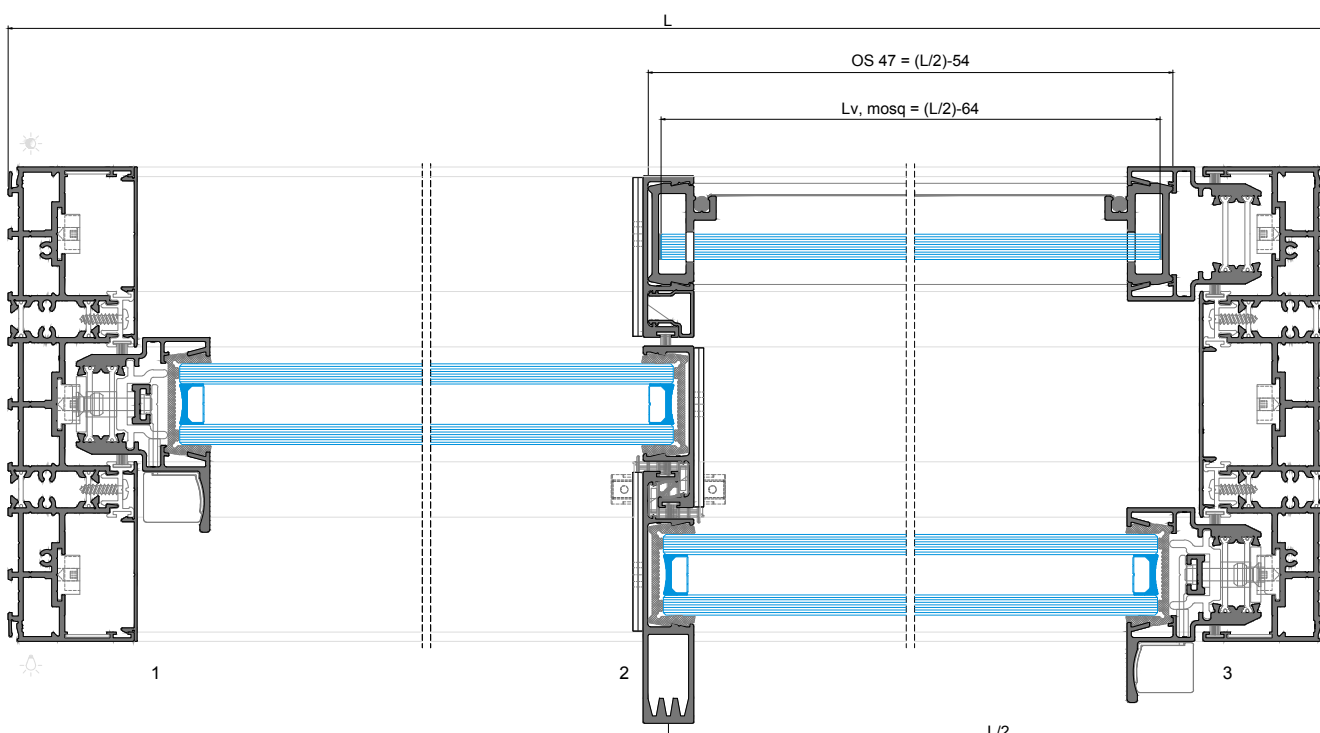
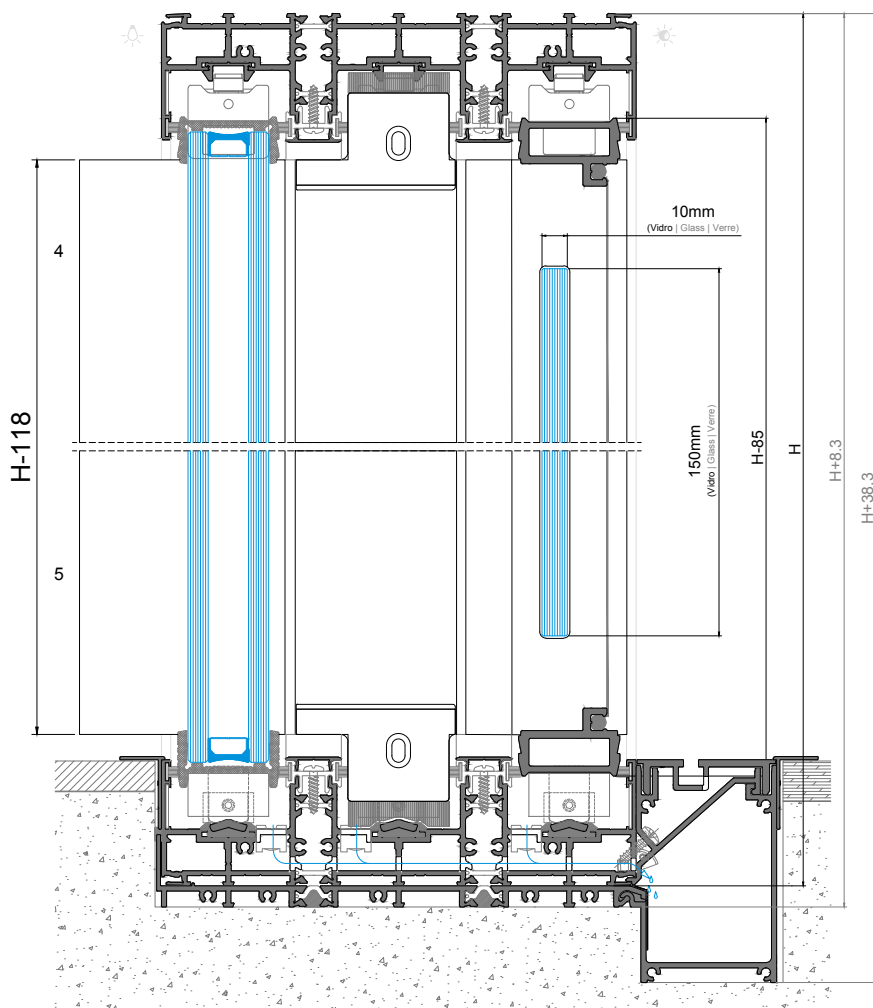
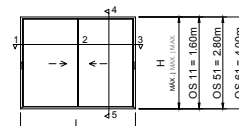

JANELA DE CORRER 2 FOLHAS - LINHA RENOVATIO
2 SASHES SLIDING WINDOW - LINE RENOVATIO
FENÊTRE COULISSANT 2 VANTAUX - LIGNE RENOVATIO

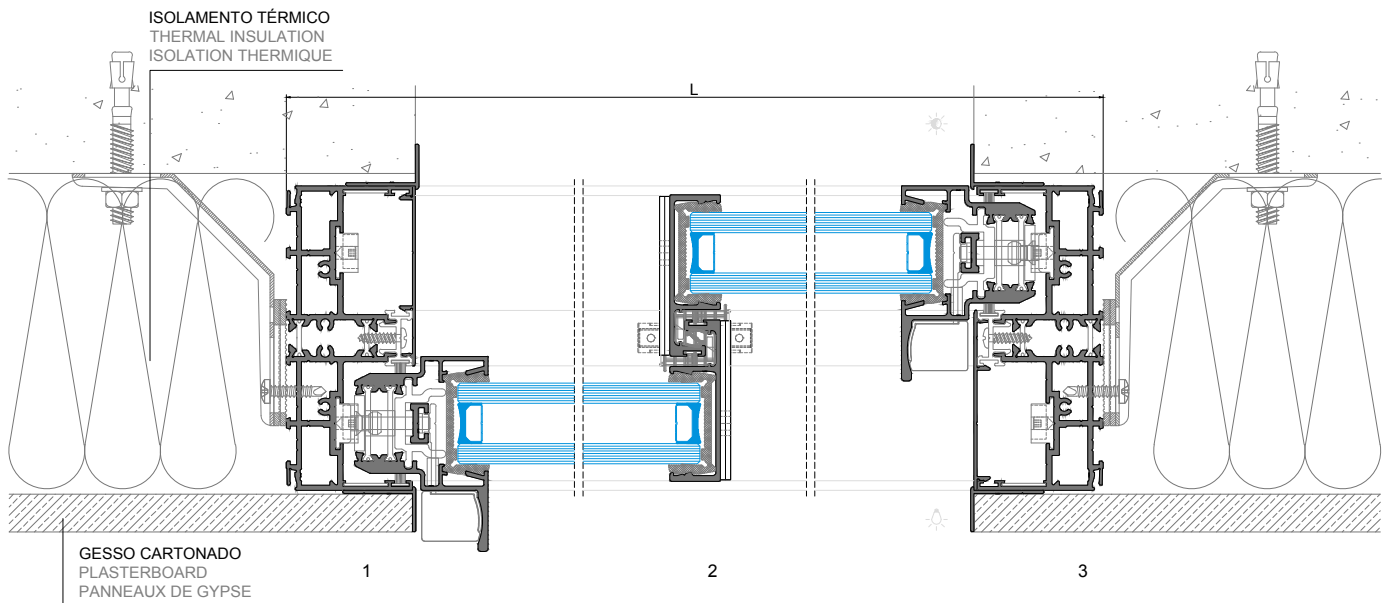
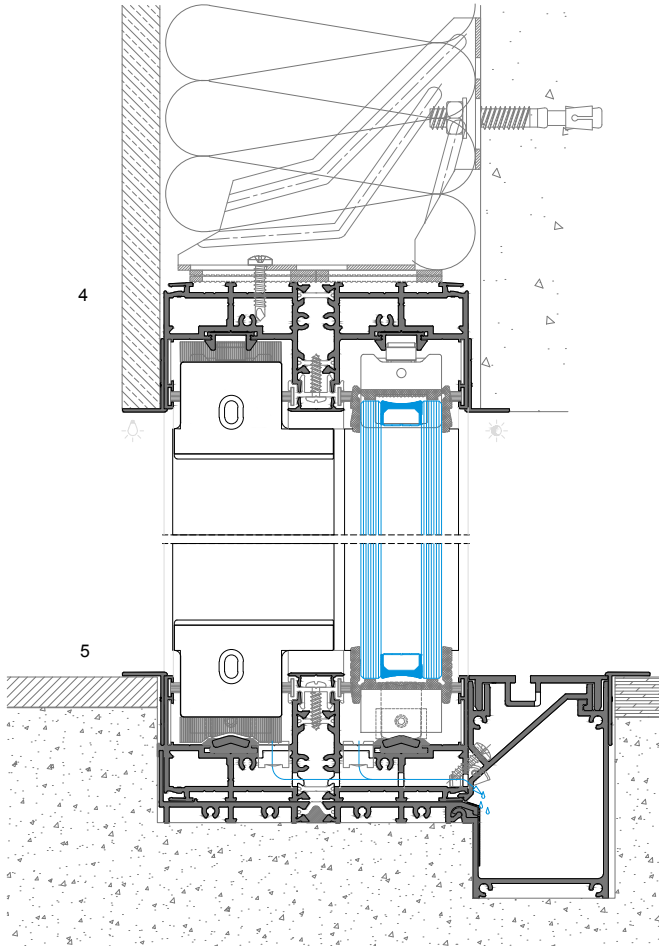
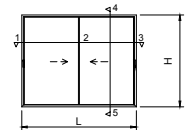

JANELA DE CORRER 2 FOLHAS COM PERFIL DE SOLEIRA SO 05 E PERFIS CENTRAIS OS 11 | OS 51 | OS 61
2 SASHES SLIDING WINDOW WITH SO 05 SILL PROFILE AND CENTRAL PROFILES OS 11 | OS 51 | OS 61
FENÊTRE COULISSANT 2 VANTAUX AVEC PROFILÉ DE SEUIL SO 05 ET PROFILÉS CENTRALES OS 11 | OS 51 | OS 61

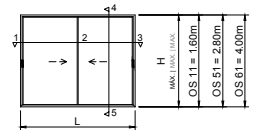

PERFIS PROFILÉS PROFILÉS					
CÓDIGO CODE	DESIGNAÇÃO DESIGNATION NOMINATION	CORTE HORIZ. HORIZONTAL-DETAIL DÉTAIL HORIZONTAL	CORTE VERT. VERTICAL-DETAIL DÉTAIL VERTICALE	QUANT. QUANTITY QUANTITÉ	CORTE CUT COUPE
SO 11	ARO FIXO FIXED FRAME DORMANT	L	H	1+2	
SO 05	ARO FIXO SOLEIRA FIXED SILL FRAME SEUIL	L	-	1	
OS 11 ou OS 10 OS 51 ou OS 10 OS 61	ARO MÓVEL CENTRAL PROFILE PROFILÉ	-	H-103	2	
SO 30	VARETA ROD PROFILE TIGE	-	H-207	2	
SO 60	TAMPA DE CANAL TRACK COVER PROFILÉ CACHE CANAL	-	H-31	2	
SO 66	ARO MÓVEL LATERAL MOBILE FR. OUVRANT	-	H-103	2	
OS 35	GUIA SUP. UPPER GUIDE GUIDE SUPÉRIEUR	L-46	-	2	
OS 801	GUIA INF. INOX LOWER GUIDE GUIDE INFÉRIEUR	L-46	-	2	
OS 95	POLIAMIDA POLYAMIDE POLYAMIDE	(L/2)-50	H-59	4+2	
OS 30	PERFIL REMATE PROFILE PROFILÉ	(L/2)-65	-	4	
SO 82	PERFIL SOLEIRA SILL PROFILE PROFILÉ DE SEUIL	L	-	1	

ACESSÓRIOS ACCESSORIES ACCESSOIRES		
CÓDIGO CODE	DESIGNAÇÃO DESIGNATION NOMINATION	QUANTIDADE QUANTITY QUANTITÉ
205162	CARRINHO OS N°5 ROLLER BEARING ROULEAU	4
205161	CARRINHO-GUIA OS SUPERIOR N°3 UPPER-GUIDE ROLLER BEARING N3 ROULEAU-GUIDE SUPÉRIEUR N3	4
205172	ESQUADRO 18-2210-D BLOCKING BRACKET ÉQUERRE	8
213018	CANTO DE ALINHAMENTO OS N.2 ANGLE ANGLE	8
202323	CONTRA-FECHO OS INOX C/ AFINAÇÃO N°2 COUNTER-LOCK BRACKET CONTRE-FERMETURE SUPPORT	6
213220	AMORTECEDOR OS N.3 SHOCK ABSORBER AMORTISSEUR	4
280000	TESTA OS-D P/FECHO OS N.2 STRIKING PLATE GÂCHE	6
201089	FECHO LATERAL OS N°4 N°3 LATERAL LOCK SERRURE LATÉRALE N°3	2
215037	PEÇA AJUSTE P/FECHO LAT OS N.4 ADJUSTMENT PIECE PIECE DE RÉGLAGE	12
228166	MOLA PARA RETENÇÃO DE FECHO OS OS LOCK RETAINER SPRING RESSORT DE RETENUE POUR FERMETURE OS	2
210094	TOPO CENTRAL N°2 OS-V2 ESQUERDO CENTRAL N°2 LEFT END-CAP EMBOUT CENTRAL N°2 GAUCHE	2
210095	TOPO CENTRAL N°2 OS-V2 DIREITO CENT. N°2 RIGHT END-CAP EMBOUT CENT. N°2 DROITE	2
210137	TOPO LATERAL SUP/INF N°3 OS-V2 LAT. UPPER/LOWER N°3 OS-V2 END-CAP EMBOUT LAT SUP/INF N°3 OS-V2	4
213273	CORTA-VENTO OS SUPERIOR UPPER CENTRAL GASKET PIÈCE D'ÉTANCHÉITE SUPÉRIEUR	1
213274	CORTA-VENTO OS INFERIOR LOWER CENTRAL GASKET PIÈCE D'ÉTANCHÉITE INFÉRIEUR	1
210260	TOPO P/ OS 33 END-CAP EMBOUT	4
212065	CONJUNTO TOPOS OS 51 * OS 51 END-CAP KIT KIT D'EMBOUT OS 51	2
212066	CONJUNTO TOPOS OS 61 * OS 61 END-CAP KIT KIT D'EMBOUT OS 61	2
210268	GOTEIRA C/ VÁLVULA SVE FLAP VALVE CLAPET À VOLET	DIVERSOS DIVERSES DIVERS
210265	GOTEIRA C/ VÁLVULA BOLA BALL VALVE CLAPET À BILLE	DIVERSOS DIVERS
290020	PARAFUSO PAR 006 SCREW VIS	DIVERSOS DIVERSES DIVERS
215078	PEÇA ANTI-LEVANTAMENTO OS ANTI-LIFT ACCESSORY ANTI-LEVAGE ACCESSOIRE	2
215083	ANTI-LEVANTAMENTO GUIA INOX OS OS GUIDE ANTI-LIFT ACCESSORY ACCESSOIRE ANTI-LEVAGE POUR GUIDE INOX OS	4
215194	CHAPA BLOQUEIO PELÚCIA PILE SEAL LOCK PLATE PLAQUE DE VERROUILLAGE DE JOINT BROSSE	4
210510	TOPO BLOQUEIO PELÚCIA CV PILE SEAL LOCK END-CAP CV EMBOUT DE VERROUILLAGE DE JOINT BROSSE CV	4
210255	TOPO PARA SO 05 SO 05 END-CAP EMBOUT POUR SO 05	2

* OPCIONAL | OPTIONAL | OPTIONNEL

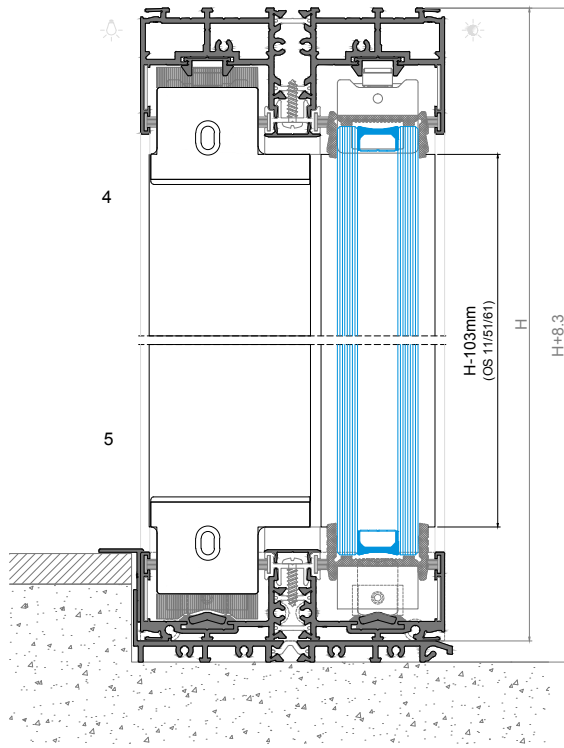

VEDANTES SEALENTS JOINTS		
CÓDIGO CODE	DESIGNAÇÃO DESIGNATION NOMINATION	QUANTIDADE QUANTITY QUANTITÉ
208450 ou OS 100	PELÚCIA 7x5.5 Cinza PILE SEAL JOINT BROSSE	8L
208465	PELÚCIA 7x5.5 Preta PILE SEAL JOINT BROSSE	8L
208460	PELÚCIA 7x7 S-F PILE SEAL JOINT BROSSE	6H
208597	PELÚCIA SRF SRF 4X8X100 2P1M PILE SEAL JOINT BROSSE	4un.
208499	VD 2063.N	2H
208499	VD 2063.N	2H

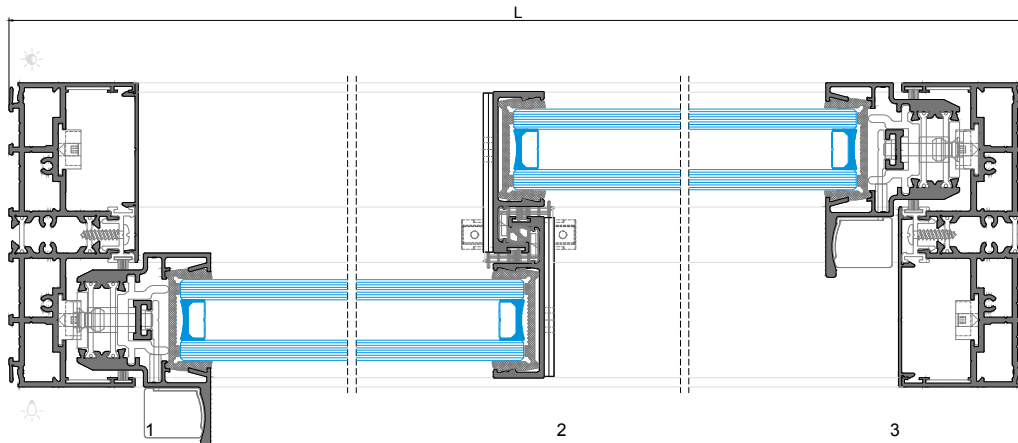



Hofmann House | Valencia | Fran Silvestre, Arq | Fotografia FG+SG

V

TIPOLOGIAS E MAPA DE QUANTIDADES - OS-D⁺ SOLEIRA OCULTA TYPOLOGIES AND QUANTITY MAPS - OS-D⁺ CONCEALED SILL TYPOLOGIES ET CARTES DE QUANTITÉS - OS-D⁺ SEUIL CACHÉ

Tipologias para vãos fixos Fixed frames typologies Typologies pour cadres fixes	V.1
Tipologias standard Standard typologies Typologies standard	V.2
Tipologias de embutir Pocket typologies Typologies à galandage	V.3
Tipologias de fechadura Locker typologies Typologies avec serrure	V.4
Outras tipologias Other typologies Autres typologies	V.5

VÃO FIXO 1 FOLHA
1 SASH FIXED FRAME
CADRE FIXE À 1 VANTAIL

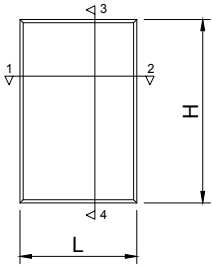

PERFIL | PROFILE | PROFILÉ - OS 08

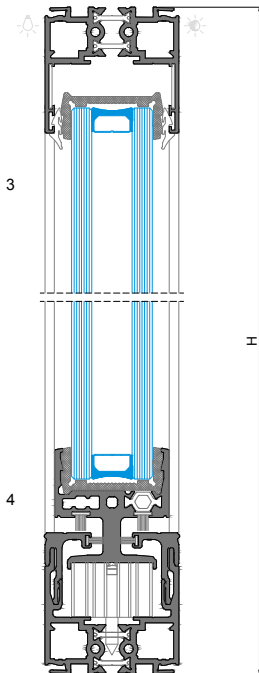

PERFIL | PROFILE | PROFILÉ - OS 18

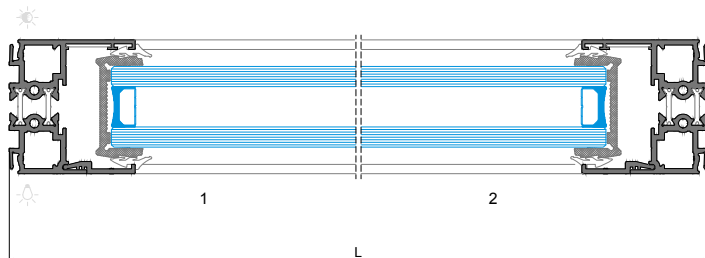
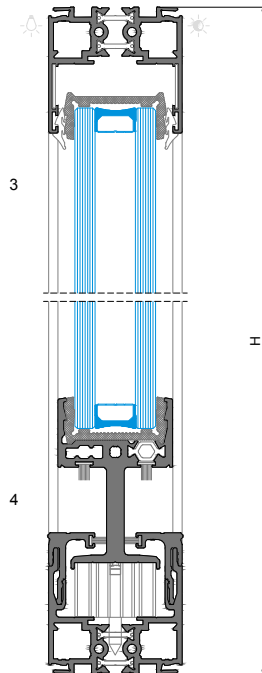

PERFIS PROFILES PROFILÉS					
CÓDIGO CODE	DESIGNAÇÃO DESIGNATION NOMINATION	CORTE HORIZ. HORIZONTAL-DETAIL DETAIL HORIZONTAL	CORTE VERT. VERTICAL-DETAIL DETAIL VERTICALE	QUANT. QUANTITY QUANTITÉ	CORTE CUT COUPE
SO 14	ARO FIXO FIXED FRAME DORMANT	L	-	1	
SO 15	ARO FIXO FIXED FRAME DORMANT	-	H	2	
SO 24	ARO FIXO SOLEIRA FIXED SILL FRAME SEUIL	L	-	1	
SO 16	BITE BEAD PARCLOSE	-	H-106	2	
OS 08 OS 18	ARO MÓVEL MOBILE FR. OUVRANT	L-71	-	1	
OS 40	PERFIL REMATE PROFILE PROFILÉ	L-100	-	2	

ACESSÓRIOS ACCESSORIES ACCESSOIRES		
CÓDIGO CODE	DESIGNAÇÃO DESIGNATION NOMINATION	QUANTIDADE QUANTITY QUANTITÉ
205173	ESQUADRO 18-1310-C BLOCKING BRACKET EQUERRE	8
213018	CANTO ALINHAMENTO OS N.2 ANGLE ANGLE	4
218134	CALÇO FIXO OS-DOUBLE OS-DOUBLE FIXED SHIM CALE FIXE OS-DOUBLE	2
210288	GOTEIRA C/ VÁLVULA SVE FLAP VALVE CLAPET À VOLET	2
290020	PARAFUSO PAR 006 SCREW VIS	DIVERSOS DIVERSES DIVERS

VEDANTES SEALENTS JOINTS		
CÓDIGO CODE	DESIGNAÇÃO DESIGNATION NOMINATION	QUANTIDADE QUANTITY QUANTITÉ
208199	JUNTA DE CUNHA 2073 GASKET JOINT	2L+4H
208458 ou 071 ou 208467	PELÚCIA 7x7 Cinza PILE SEAL JOINT BROSSE (OS 08 OS 18) ou ou ou	2L
208468	PELÚCIA SRF 4x8 2P1M Cinza PILE SEAL JOINT BROSSE (OS 48)	2L

JANELA DE CORRER 2 FOLHAS
2 SASHES SLIDING WINDOW
FENÊTRE COULISSANT 2 VANTAUX

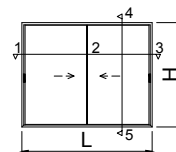

PERFIL | PROFILE | PROFILÉ - OS 08

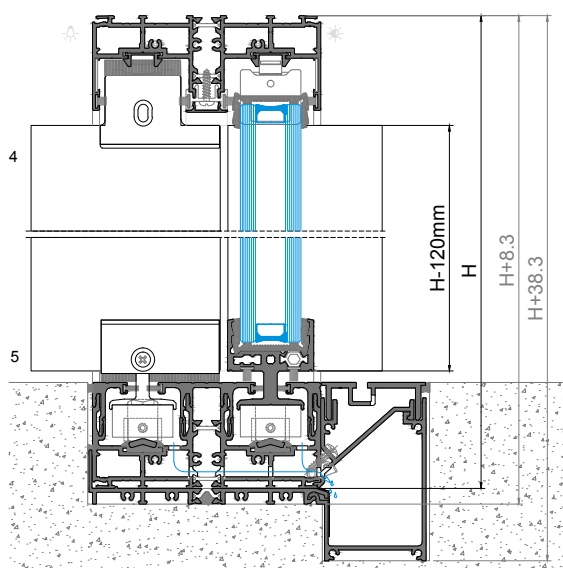

PERFIL | PROFILE | PROFILÉ - OS 18

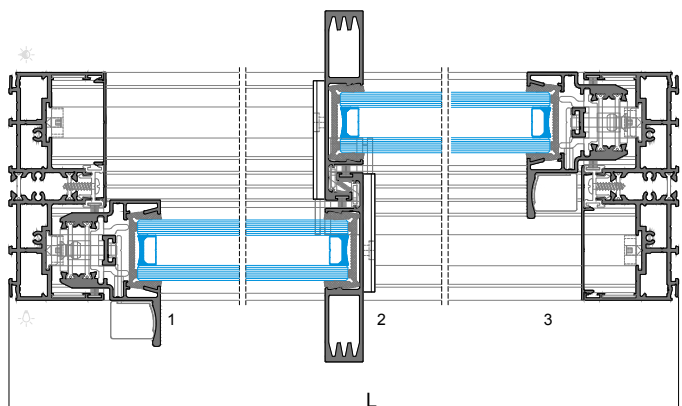
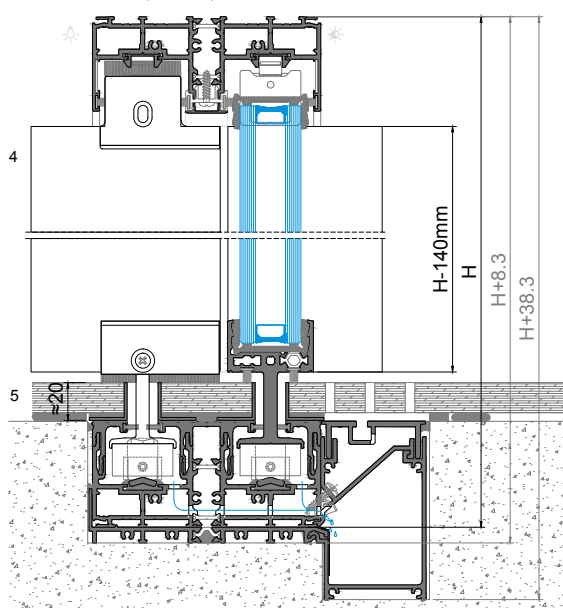

PERFIS PROFILES PROFILÉS					
CÓDIGO CODE	DESIGNAÇÃO DESIGNATION / NOMINATION	CORTE HORIZ. HORIZONTAL DETAIL DETAIL HORIZONTAL	CORTE VERT. VERTICAL DETAIL DETAIL VERTICALE	QUANT. QUANTITY	CORTE CUT / COUPE
SO 11	ARO FIXO FIXED FRAME DORMANT	L	H	1+2	
SO 21	ARO FIXO SOLEIRA FIXED SILL FRAME SEUIL	L	-	1	
SO 66	ARO MÓVEL LATERAL MOBILE FR. OUVRANT	-	H-120 H-140	2	
SO 30	VARETA ROD PROFILE TIGE	-	VARIÁVEL VARIABLE / VARIABLE	2	
OS 61	ARO MÓVEL CENTRAL PROFILE PROFILÉ	-	H-120 H-140	2	
OS 08 OS 18	ARO MÓVEL MOBILE FR. OUVRANT	(L/2)-56	-	2	
OS 40	PERFIL REMATE PROFILE PROFILÉ	(L/2)-50,5	-	4	
OS 41	PERFIL REMATE PROFILE PROFILÉ	(L-130)/2	-	2	
OS 801	GUIA INF. INOX LOWER GUIDE GUIDE INFÉRIEUR	L-46	-	2	
OS 35	GUIA SUP. UPPER GUIDE GUIDE SUPÉRIEUR	L-46	-	2	
OS 95	POLIAMIDA POLYAMIDE POLYAMIDE	(L/2)-50	H-74	2+2	
OS 30	PERFIL REMATE PROFILE PROFILÉ	(L/2)-65	-	2	
SO 60	TAMPA DE CANAL DRAINAGE CHANNEL / PROFILE CACHE CANAL	-	H-79	2	
SO 82	PERFIL SOLEIRA SILL PROFILE / PROFILÉ DE SEUIL	CONSULTAR DEPARTAMENTO TÉCNICO CONSULT TECHNICAL DEPARTMENT CONSULTER DÉPARTEMENT TECHNIQUE			
SO 25	PERFIL CALEIRA DRAINAGE CHANNEL / GOUTTIÈRE DE VIDANGE				
SO 69	TAMPA DE CALEIRA DRAINAGE CHANNEL GRID / GRILLE POUR GOUTTIÈRE DE VIDANGE				
VO 11	PERFIL FIXAÇÃO TAMPA DRAINAGE CHANNEL / GRID FIX. PROF. PROF. FIXATION GRILLE				

(1) Peças com 400mm, aplicadas aproximadamente a cada 800mm | Pieces 400mm long, applied approximately every 800mm | Pièces de 400 mm, appliquées à environ tous les 800 mm

ACESSÓRIOS ACCESSORIES ACCESSOIRES		
CÓDIGO CODE	DESIGNAÇÃO DESIGNATION / NOMINATION	QUANTIDADE QUANTITY / QUANTITÉ
205162	CARRINHO OS N°5 ROLLER BEARING ROULEAU	4
205161	CARRINHO-GUIA OS SUPERIOR N°3 UPPER-GUIDE ROLLER BEARING N3 ROULEAU-GUIDE SUPÉRIEUR N3	4
205172	ESQUADRO 18-2210-D BLOCKING BRACKET ÉQUERRE	8
213018	CANTO ALINHAMENTO OS N.2 ANGLE ANGLE	4
202323	CONTRA-FECHO OS INOX C/ AFINAÇÃO N°2 COUNTER-LOCK BRACKET / CONTRE-FERMETURE SUPPORT	6
213220	AMORTECEDOR OS N.3 SHOCK ABSORBER AMORTISSEUR	4
201089	FECHO LATERAL OS N°4 N.4 LATERAL LOCK SERRURE LATÉRALE N.4	2
280000	TESTA OS-D P/FECHO OS N.2 STRIKING PLATE GÂCHE	6
215037	PEÇA AJUSTE P/FECHO LAT OS N.4 ADJUSTMENT PIECE / PIÈCE DE REGULAGE	8
228186	MOLA PARA RETENÇÃO DE FECHO OS OS LOCK RETAINER SPRING RESSORT DE RETENUE POUR FERMETURE OS	2
210125	TOPO CENTRAL N°6 OS-V2 SOL OCULTA ESQ CENTRAL END-CAP N°6 OS-V2 LEFT EMBOUT CENTRAL N°6 OS-V2 GAUCHE	2
210095	TOPO CENTRAL N°2 OS-V2 DIREITO CENT. V2-RIGHT END-CAP / EMBOUT CENT. V2 DROITE	2
210165	TOPO LATERAL SUP/INF N°15 OS-V2 LAT. UPPER/LOWER N°15 OS-V2 END-CAP / EMBOUT LAT SUP/INF N°15 OS-V2	2
210166	TOPO LAT. INF. 20mm N°16 OS-V2 Sol. Invisível (OS 08) LAT. INF. 20mm N°16 END-CAP EMBOUT LAT. INF. 20mm N°16 ou or ou	2
210167	TOPO LAT. INF. 40mm N°17 OS-V2 Sol. Invisível (OS 18) LAT. INF. 40mm N°17 END-CAP EMBOUT LAT. INF. 40mm N°17	2
210159	TOPO ARO FIXO SOLEIRA OCULTA V2-N2 CONCEALED SILL FIXED FRAME END-CAP V2-N2 EMBOUT CADRE DORMANT SEUIL CACHE V2-N2	4
212066	CONJUNTO TOPOS OS 61 OS 61 END-CAP KIT / KIT D'EMBOUT OS 61	2
213273	CORTA-VENTO OS SUPERIOR UPPER CENTRAL GASKET PIÈCE D'ÉTANCHÉITE SUPÉRIEUR	1
213281	CORTA-VENTO SOL OCULTA OS 08 CONCEALED CENTRAL GASKET PIÈCE D'ÉTANCHÉITE CACHÉE (OS 08) ou or ou	1
213275	CORTA-VENTO SOL OCULTA OS 18 CONCEALED CENTRAL GASKET PIÈCE D'ÉTANCHÉITE CACHÉE (OS 18)	1
210268	GOTEIRA C/ VÁLVULA SVE FLAP VALVE CLAPET À VOLET	DIVERSOS DIVERSES / DIVERS
290020	PARAFUSO PAR 006 SCREW VIS	DIVERSOS DIVERSES / DIVERS
215078	PEÇA ANTI-LEVANTAMENTO OS ANTI-LIFT ACCESSORY ANTI-LEVAGE ACCESSOIRE	2
215083	ANTI-LEVANTAMENTO GUIA INOX OS OS GUIDE ANTI-LIFT ACCESSORY ACCESSOIRE ANTI-LEVAGE POUR GUIDE	4
215194	CHAPA BLOQUEIO PELÚCIA PILE SEAL LOCK PLATE / PLAQUE DE VERROUILLAGE DE JOINT BROSSÉ	2
210510	TOPO BLOQUEIO PELÚCIA CV1 PILE SEAL LOCK END-CAP CV / EMBOUT DE VERROUILLAGE DE JOINT BROSSÉ CV	2
212246	CONJ. TOPOS CAL/SOL. OS-D 2-RAIL DRAINAGE CHANNEL/SILL OS-D 2-RAIL END-CAP KIT / KIT D'EMBOUT DE GOUTTIÈRE/SEUIL OS-D 2-RAIL	1
210604	TAPA FUROS P/ AMORTECEDOR OS N.3 HOLE COVER FOR SHOCK ABSORBER N.3 COUVERCLE DE TROU POUR AMORTISSEUR N.3	2

* Opcional | Optional | Optionnel

VEDANTES SEALENTS JOINTS		
CÓDIGO CODE	DESIGNAÇÃO DESIGNATION / NOMINATION	QUANTIDADE QUANTITY / QUANTITÉ
208460 ou or ou 208465	PELÚCIA 7x5.5 Cinza PILE SEAL JOINT BROSSÉ	4L
208460 ou or ou 208467	PELÚCIA 7x7 S-F PILE SEAL JOINT BROSSÉ	6H
208458 ou or ou 208467	PELÚCIA 7x7 Cinza PILE SEAL JOINT BROSSÉ (OS 08 OS 18)	2L
208468	PELÚCIA SRF 4x8 2P1M GRA Cinza PILE SEAL JOINT BROSSÉ	4L
208499	VD 2063.N	2H
208193	VD 2060	2L

JANELA DE CORRER 4 FOLHAS - COM PERFIL OS 27
4 SASHES SLIDING WINDOW - WITH OS 27 PROFILE
FENÊTRE COULISSANT 4 VANTAOX - AVEC PROFILÉ OS 27

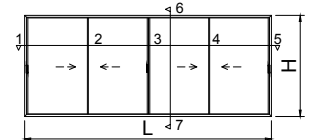

ACESSÓRIOS ACCESSORIES ACCESSOIRES		
CÓDIGO CODE	DESIGNAÇÃO DESIGNATION NOMINATION	QUANTIDADE QUANTITY QUANTITÉ
205162	CARRINHO OS Nº5 ROLLER BEARING ROULEAU	8
205161	CARRINHO-GUIA OS SUPERIOR Nº3 UPPER-GUIDE ROLLER BEARING N3 ROULEAU-GUIDE SUPERIEUR N3	8
205172	ESQUADRO 18-2210-D BLOCKING BRACKET ÉQUERRE	8
213018	CANTO ALINHAMENTO OS N.2 ANGLE ANGLE	8
202323	CONTRA-FECHO OS INOX C/ AFINAÇÃO Nº2 COUNTER-LOCK BRACKET CONTRE-FERMETURE SUPPORT	6
213220	AMORTECEDOR OS N.3 SHOCK ABSORBER AMORTISSEUR	4
201089	FECHO LATERAL OS Nº4 N.4 LATERAL LOCK SERRURE LATÉRALE N.4	3
280000	TESTA OS-D P/FECHO OS N.2 STRIKING PLATE GÂCHE	6
215037	PEÇA AJUSTE P/FECHO LAT OS N.4 ADJUSTEMENT PIECE PIECE DE REGLAGE	2
228166	MOLA PARA RETENÇÃO DE FECHO OS OS LOCK RETAINER SPRING RESORT POUR FERMUTURE OS	8
210094	TOPO CENTRAL Nº2 OS-V2 ESQUERDO CENTRAL Nº2 LEFT END-CAP EMBOUT CENTRAL Nº2 GAUCHE	2
210095	TOPO CENTRAL Nº2 OS-V2 DIREITO CENT. Nº2 RIGHT END-CAP EMBOUT CENT. Nº2 DROITE	2
210125	TOPO CENTRAL Nº6 OS-V2 SOL OCULTA ESQUERDO CENTRAL Nº6 LEFT END-CAP EMBOUT CENTRAL Nº6 GAUCHE	2
210126	TOPO CENTRAL Nº6 OS-V2 SOL OCULTA DIREITO CENT. Nº6 RIGHT END-CAP EMBOUT CENT. Nº6 DROITE	2
210165	TOPO LATERAL SUP/INF Nº15 OS-V2 LAT. UPPER/LOWER Nº15 OS-V2 END-CAP EMBOUT LAT SUP/INF Nº15 OS-V2	2
210166	TOPO LAT. INF. 20mm Nº16 OS-V2 Sol. Invisível (OS 08) LAT. INF. 20mm Nº16 END-CAP EMBOUT LAT. INF. 20mm Nº16 ou 16 16	2
210167	TOPO LAT. INF. 40mm Nº17 OS-V2 Sol. Invisível (OS 18) LAT. INF. 40mm Nº17 END-CAP EMBOUT LAT. INF. 40mm Nº17 ou 17 17	2
210159	TOPO ARO FIXO SOLEIRA OCULTA V2-N2 CONCEALED SILL FIXED FRAME END-CAP V2-N2 EMBOUT CHÂSSIS DORMANT SEUIL CACHE V2-N2	4
213273	CORTA-VENTO OS SUPERIOR UPPER CENTRAL GASKET PIÈCE D'ÉTANCHÉITE SUPÉRIEUR	2
213281	CORTA-VENTO SOL OCULTA OS 08 CONCEALED CENTRAL GASKET PIÈCE D'ÉTANCHÉITE CACHÉE (OS 08)	2
213275	CORTA-VENTO SOL OCULTA OS 18 CONCEALED CENTRAL GASKET PIÈCE D'ÉTANCHÉITE CACHÉE (OS 18)	2
212066	CONJUNTO TOPOS OS 61 OS 61 END-CAP KIT KIT D'EMBOUT OS 61	3
212124	CONJ. TOPOS PARA OS 27 END-CAPS EMBOUT	2
210268	GOTEIRA C/ VÁLVULA SVE FLAP VALVE CLAPET À VOILE	DIVERSOS DIVERSES DIVERS
290020	PARAFUSO PAR 006 SCREW VIS	DIVERSOS DIVERSES DIVERS
215078	PEÇA ANTI-LEVANTAMENTO OS ANTI-LIFT ACCESSORY ANTI-LEVAGE ACCESSOIRE	2
215083	ANTI-LEVANTAMENTO GUIA INOX OS OS GUIDE ANTI-LIFT ACCESSORY ACCESSOIRE ANTI-LEVAGE POUR GUIDE INOX OS	4
215194	CHAPA BLOQUEIO PELÚCIA PILE SEAL LOCK PLATE PLAQUE DE VERROUILLAGE DE JOINT BROSSÉ	8
210510	TOPO BLOQUEIO PELÚCIA CV PILE SEAL LOCK END-CAP CV EMBOUT DE VERROUILLAGE DE JOINT BROSSÉ CV	8
210604	TAPA FUROS P/ AMORTECEDOR OS N.3 HOLE COVER FOR SHOCK ABSORBER N.3 COUVERCLE DE TROU POUR AMORTISSEUR N.3	2

* Opcional | Optional | Optionnel

PERFIS PROFILES PROFILÉS					
CÓDIGO CODE	DESIGNAÇÃO DESIGNATION NOMINATION	CORTE HORIZ. HORIZONTAL DETAIL	CORTE VERT. VERTICAL DETAIL	QUANT. QUANTITY	CORTE CUT
SO 11	ARO FIXO FIXED FRAME DORMANT	L	H	1+2	
SO 21	ARO FIXO SOLEIRA FIXED SILL FRAME SEUIL	L	-	1	
OS 27	PERFIL UNIÃO 3/4 F UNION PROFILE PROFILÉ UNION	-	H-122 H-142	1	
OS 61	ARO MÓVEL CENTRAL PROFILE PROFILÉ	-	H-120 H-140	4	
SO 65	ARO MÓVEL LATERAL MOBILE FR. OUVRANT	-	H-120 H-140	3	
SO 30	VARETA ROD PROFILE TIGE	-	VARIÁVEL VARIABLE VARIABLE	3	
SO 30	TAMPA DE CANAL TRACK COVER PROFILÉ CACHE CANAL	-	H-79	2	
SO 65	GUIA SUP. UPPER GUIDE GUIDE SUPÉRIEUR	L-46	-	2	
OS 801	GUIA INF. INOX LOWER GUIDE GUIDE INFÉRIEUR	L-46	-	2	
OS 95	POLIAMIDA POLYAMIDE POLYAMIDE	(L-132)/4 (L-115)/2	H-74	2+2	
OS 30	PERFIL REMATE PROFILE PROFILÉ	(L-195)/2 (L-120)/2	-	2 1	
OS 08	ARO MÓVEL MOBILE FR. OUVRANT	(L-158)/4	-	4	
OS 40	PERFIL REMATE PROFILE PROFILÉ	(L-159)/4 (L-65)/2	-	4 2	
SO 82	PERFIL SOLEIRA SILL PROFILE PROFILÉ DE SEUIL	(L-220)/4 (L-280)/2	-	2 1	
SO 25	PERFIL CALEIRA DRAINAGE CHANNEL GOUTTIÈRE DE VIDANGE	CONSULTAR DEPARTAMENTO TÉCNICO CONSULT TECHNICAL DEPARTMENT CONSULTER DÉPARTEMENT TECHNIQUE			
SO 26	TAMPA DE CALEIRA DRAINAGE CHANNEL GRID GRILLE POUR GOUTTIÈRE DE VIDANGE				
VO 11	PERFIL FIXAÇÃO TAMPA DRAINAGE CHANNEL GRID FIX. PROF. PROF. FIXATION GRILLE				

(1) Peças com 400mm, aplicadas aproximadamente a cada 800mm | Pieces 400mm long, applied approximately every 800mm | Pièces de 400 mm, appliquées à environ tous les 800 mm.

VEDANTES SEALENTS JOINTS		
CÓDIGO CODE	DESIGNAÇÃO DESIGNATION NOMINATION	QUANTIDADE QUANTITY QUANTITÉ
208450 ou 07, 08, 09, 10, 11, 12, 13, 14, 15, 16, 17, 18, 19, 20, 21, 22, 23, 24, 25, 26, 27, 28, 29, 30, 31, 32, 33, 34, 35, 36, 37, 38, 39, 40, 41, 42, 43, 44, 45, 46, 47, 48, 49, 50, 51, 52, 53, 54, 55, 56, 57, 58, 59, 60, 61, 62, 63, 64, 65, 66, 67, 68, 69, 70, 71, 72, 73, 74, 75, 76, 77, 78, 79, 80, 81, 82, 83, 84, 85, 86, 87, 88, 89, 90, 91, 92, 93, 94, 95, 96, 97, 98, 99, 100	PELÚCIA 7x5.5 Cinza PILE SEAL JOINT BROSSÉ ou or ou	6L
208465	PELÚCIA 7x5.5 Preta PILE SEAL JOINT BROSSÉ	6L
208460	PELÚCIA 7x7 S-F PILE SEAL JOINT BROSSÉ	10H
208597	PELÚCIA SRF SRF 4X8X100 2P1M PILE SEAL JOINT BROSSÉ	8un.
208499	VD 2063.N	6H
208193	VD 2060	2L

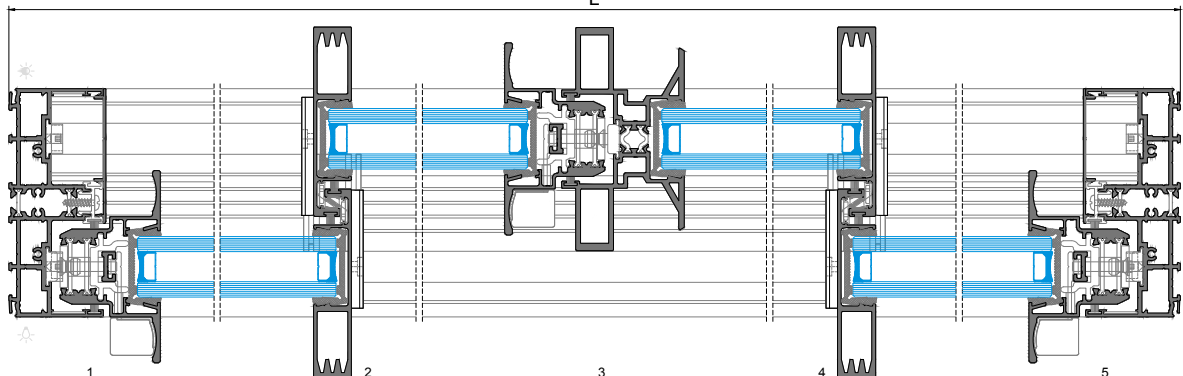
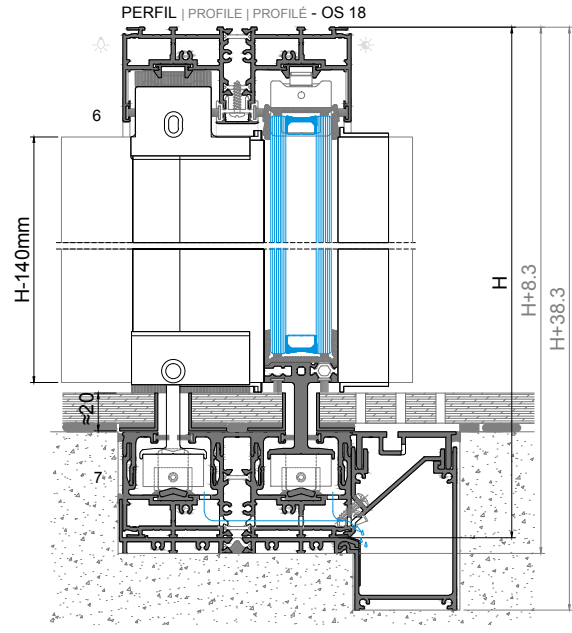
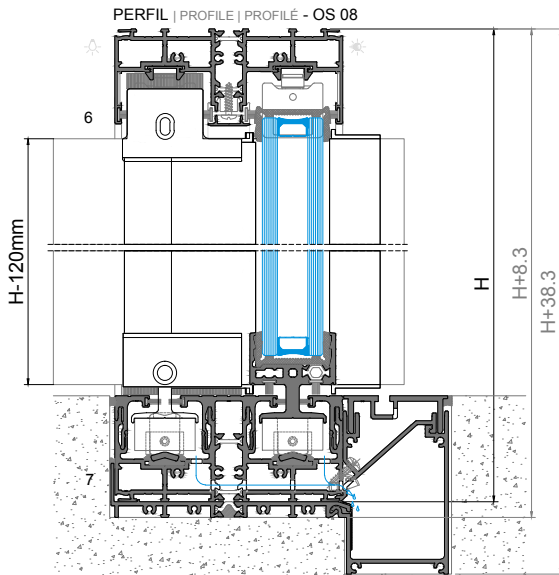

JANELA DE CORRER 4 FOLHAS - COM PERFIS SO 38 + SO 39
4 SASHES SLIDING WINDOW - WITH SO 38 + SO 39 PROFILES
FENÊTRE COULISSANT 4 VANTAOX - AVEC PROFILÉS SO 38 + SO 39

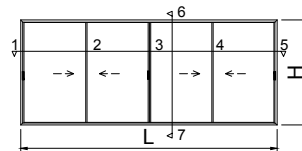

VEDANTES SEALENTS JOINTS		
CÓDIGO CODE	DESIGNAÇÃO DESIGNATION NOMINATION	QUANTIDADE QUANTITY QUANTITÉ
208450 ou or ou	PELÚCIA 7x5.5 Cinza PILE SEAL JOINT BRUSSE	6L
208465	PELÚCIA 7x5.5 Preta PILE SEAL JOINT BRUSSE	
208450	PELÚCIA 7x5.5 PILE SEAL JOINT BRUSSE (SO 38 SO 39)	3H
208460	PELÚCIA 7x7 S-F PILE SEAL JOINT BRUSSE	8H
208597	PELÚCIA SRF SRF 4X8X100 2P1M PILE SEAL JOINT BRUSSE	8un.
208499	VD 2063.N	6H
208193	VD 2060	2L
208225	JUNTA DE ESTANQUIDADE 2050 GASKET JOINT	1H

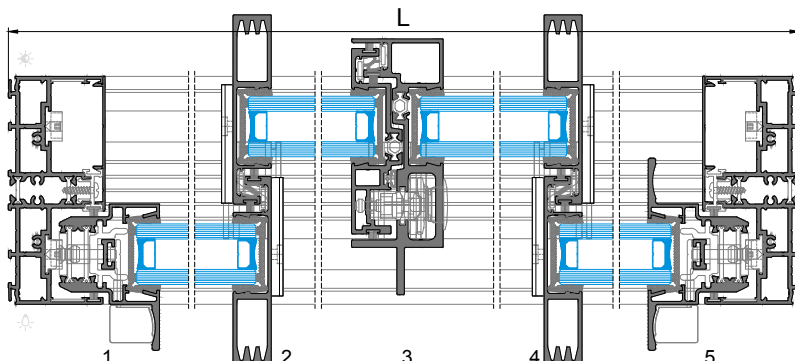
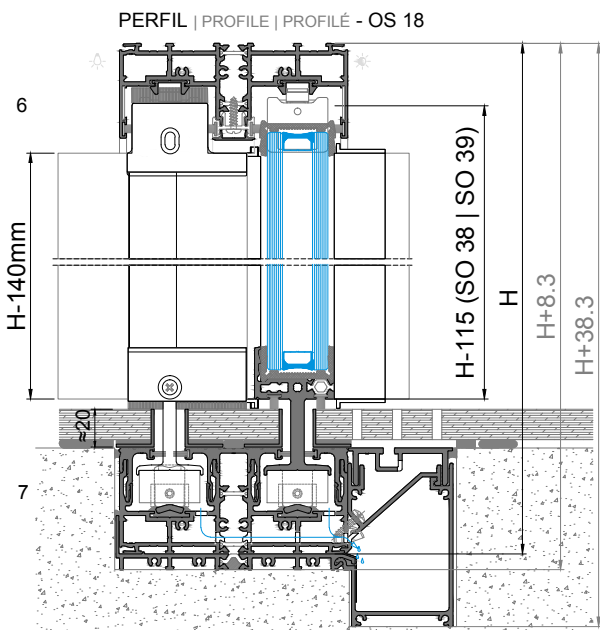
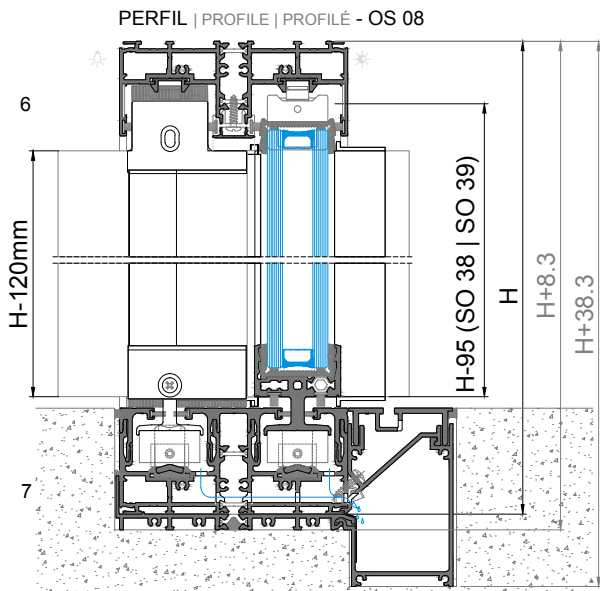

PERFIS PROFILES PROFILÉS						
CÓDIGO CODE	DESIGNAÇÃO DESIGNATION NOMINATION	CORTE HORIZ. HORIZONTAL DETAIL	CORTE VERT. VERTICAL DETAIL		QUANT. QUANTITY	CORTE COUPE
			OS 08	OS 18		
SO 11	ARO FIXO FIXED FRAME DORMANT	L	H		1+2	
SO 21	ARO FIXO SOLEIRA FIXED SILL FRAME SEUIL	L	-		1	
OS 61	ARO MÓVEL CENTRAL PROFILE PROFILÉ	-	H-120	H-140	4	
SO 38	PERFIL CENTRAL CONTRA FECHO PROFILE PROFILÉ	-	H-95	H-115	1	
SO 39	PERFIL CENTRAL FECHO PROFILE PROFILÉ	-	H-95	H-115	1	
SO 65	ARO MÓVEL LATERAL MOBILE FR. OUVRANT	-	H-120	H-140	2	
SO 30	VARETA ROD PROFILE TIGE	-		VARIÁVEL VARIABLE VARIABLE	2	
SO 33	BARRA DE CREMONE DUPLA DOUBLE CREMONE BAR TIGE CREMONE DOUBLE	-		VARIÁVEL VARIABLE VARIABLE	4	
SO 60	TAMPA DE CANAL TRACK COVER PROFILE CACHE CANAL	-		H-79	2	
OS 35	GUIA SUP. UPPER GUIDE GUIDE SUPÉRIEUR	L-46	-	-	2	
OS 801	GUIA INF. INOX LOWER GUIDE GUIDE INFÉRIEUR	L-46	-	-	2	
OS 95	POLIAMIDA POLYAMIDE POLYAMIDE	(L-85)/4 (L-212)/4	H-74		2 + 2	
OS 30	PERFIL REMATE PROFILE PROFILÉ	(L-147)/4 (L-220)/4	-		2	
OS 08	ARO MÓVEL MOBILE FR. OUVRANT	(L-111)/4	-		4	
OS 40	PERFIL REMATE PROFILE PROFILÉ	(L-88)/4 (L-112)/4	-		4	
OS 41	PERFIL REMATE PROFILE PROFILÉ	(L-149)/4 (L-233)/4	-		2	
SO 82	PERFIL SOLEIRA SILL PROFILE PROFILÉ DE SEUIL					
SO 25	PERFIL CALEIRA DRAINAGE CHANNEL GOUTTIÈRE DE VIDANGE					
SO 59	TAMPA DE CALEIRA DRAINAGE CHANNEL GRID GRILLE POUR GOUTTIÈRE DE VIDANGE					
VO 11	PERFIL FIXAÇÃO TAMPA DRAINAGE (1) CHANNEL GRID FIX. PROF. PROF. FIXATION GRILLE					

CONSULTAR DEPARTAMENTO TÉCNICO
CONSULT TECHNICAL DEPARTMENT
CONSULTER DÉPARTEMENT TECHNIQUE

(1) Peças com 400mm, aplicadas aproximadamente a cada 800mm | Pieces 400mm long, applied approximately every 800mm | Pièces de 400 mm, appliquées à environ tous les 800 mm

ACESSÓRIOS ACCESSORIES ACCESSOIRES		
CÓDIGO CODE	DESIGNAÇÃO DESIGNATION NOMINATION	QUANTIDADE QUANTITY QUANTITÉ
205162	CARRINHO OS N°5 ROLLER BEARING ROULEAU	8
205161	CARRINHO-GUIA OS SUPERIOR N°3 UPPER GUIDE ROLLER BEARING N3 ROULEAU-GUIDE SUPÉRIEUR N3	8
205172	ESQUADRO 18-2210-D BLOCKING BRACKET ÉQUERRE	8
213018	CANTO ALINHAMENTO OS N.2 ANGLE ANGLE	8
202323	CONTRA-FECHO OS INOX C/ AFINAÇÃO N°2 COUNTER-LOCK BRACKET CONTRE-FERMETURE SUPPORT	6
213220	AMORTECEDOR OS N.3 SHOCK ABSORBER AMORTISSEUR	4
201089	FECHO LATERAL OS N°4 N 4 LATERAL LOCK SERRURE LATÉRALE N 4	2
280000	TESTA OS-D P/FECHO OS N.2 STRIKING PLATE GÂCHE	6
215037	PEÇA AJUSTE P/FECHO LAT OS N.4 ADJUSTMENT PIECE PIÈCE DE RÉGLAGE	8
228166	MOLA PARA RETENÇÃO DE FECHO OS OS LOCK RETAINER SPRING RESSORT DE RETÈNE POUR FERMETURE OS	2
210094	TOPO CENTRAL N°2 OS-V2 ESQUERDO CENTRAL N°2 LEFT END-CAP EMBOUT CENTRAL N°2 GAUCHE	2
210095	TOPO CENTRAL N°2 OS-V2 DIREITO CENT. N°2 RIGHT END-CAP EMBOUT CENT. N°2 DROITE	2
210125	TOPO CENTRAL N°6 OS-V2 SOL OCULTA ESQUERDO CENTRAL N°6 LEFT END-CAP EMBOUT CENTRAL N°2 GAUCHE	2
210126	TOPO CENTRAL N°6 OS-V2 SOL OCULTA DIREITO CENT. N°6 RIGHT END-CAP EMBOUT CENT. N°2 DROITE	2
210165	TOPO LATERAL SUP/INF N°15 OS-V2 LAT. UPPER/LOWER N°15 OS-V2 END-CAP EMBOUT LAT SUP/INF N°15 OS-V2	2
210166	TOPO LAT. INF. 20mm N°16 OS-V2 Sol. Invisível (OS 08) LAT. INF. 20mm N°16 END-CAP EMBOUT LAT. INF. 20mm N°16	2
210167	TOPO LAT. INF. 40mm N°17 OS-V2 Sol. Invisível (OS 18) LAT. INF. 40mm N°17 END-CAP EMBOUT LAT. INF. 40mm N°17	2
213273	CORTA-VENTO OS SUPERIOR UPPER CENTRAL GASKET PIÈCE D'ÉTANCHÉITE SUPÉRIEUR	3
213281	CORTA-VENTO SOL OCULTA OS 08 CONCEALED CENTRAL GASKET PIÈCE D'ÉTANCHÉITE CACHÉE (OS 08)	2
213275	CORTA-VENTO SOL OCULTA OS 18 CONCEALED CENTRAL GASKET PIÈCE D'ÉTANCHÉITE CACHÉE (OS 18)	2
212066	CONJUNTO TOPOS OS 61 OS 61 END-CAP KIT KIT D'EMBOUT OS 61	4
210268	GOTEIRA C/ VÁLVULA SVE FLAP VALVE CLAPET À VOILET	DIVERSOS DIVERS DIVERS
290020	PARAFUSO PAR 006 SCREW VIS	DIVERSOS DIVERS DIVERS
215078	PEÇA ANTI-LEVANTAMENTO OS ANTI-LIFT ACCESSORY ANTI-LEVAGE ACCESSOIRE	2
215083	ANTI-LEVANTAMENTO GUIA INOX OS OS GUIDE ANTI-LIFT ACCESSORY ACCESSOIRE ANTI-LEVAGE POUR GUIDE INOX OS	4
215194	CHAPA BLOQUEIO PELÚCIA PILE SEAL LOCK PLATE PLAQUE DE VERROUILLAGE DE JOINT BRUSSE	8
210510	TOPO BLOQUEIO PELÚCIA CV PILE SEAL LOCK END-CAP CV EMBOUT DE VERROUILLAGE DE JOINT BRUSSE CV	8
290099	PARAFUSO DIN7991 M5x8 INOX A2 SCREW VIS	2
212019	CONJ. TOPOS SO38/SO39 END-CAP KIT KIT D'EMBOUT	1
212019	TOPO INF SOL OCULTA SO38/SO39 CONCEALED SILL LOWER END-CAP KIT KIT D'EMBOUT INF. SEUIL CACHÉE	1
201097	FECHO EMBUTIR OS MONODIR MONODIRECTIONAL RECESSED LOCK SERRURE À ENCASTER MONODIRECTIONNEL	1
212000	CONJ. FECHO SO38/SO39 LOCK SET KIT FERMETURE	1
290099	PARAFUSO DIN7991 M5x8 INOX A2 SCREW VIS	2
212604	TAPA FUROS P/ AMORTECEDOR OS N.3 HOLE COVER FOR SHOCK ABSORBER N.3 COUVERCLE DE TROU POUR AMORTISSEUR N.3	2

* Opcional | Optional | Optionnel
** Usar apenas os Topos superiores
Use only the upper End-caps | Utiliser uniquement l'Embout supérieure
*** 2Un./prumada para alturas até 3metros. 3Un./prumada para alturas superiores a 3 metro

JANELA DE CORRER 3 FOLHAS
3 SASHES SLIDING WINDOW
FENÊTRE COULISSANT 3 VANTAOX

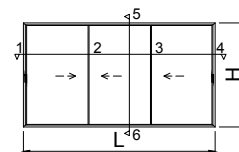

PERFIL | PROFILE | PROFILÉ - OS 08

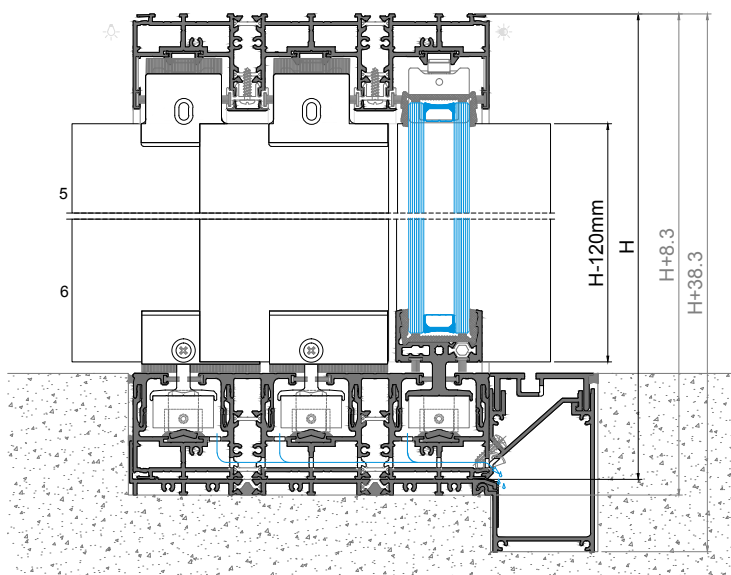

PERFIL | PROFILE | PROFILÉ - OS 18

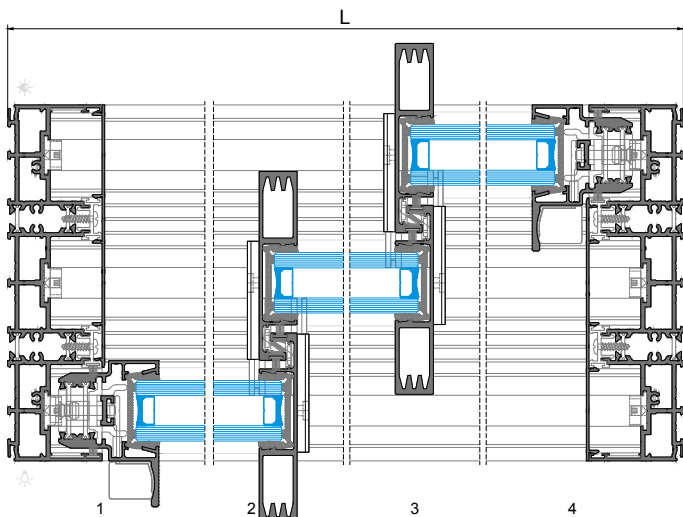
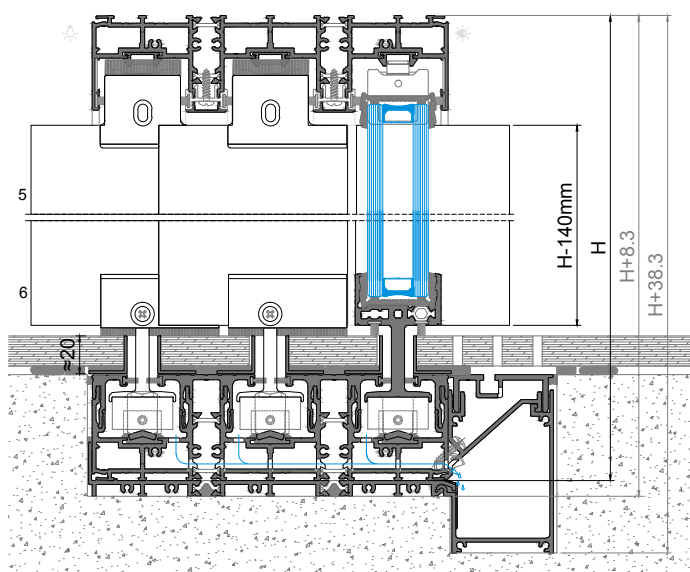

PERFIS | PROFILES | PROFILÉS

CODIGO CODE	DESIGNAÇÃO DESIGNATION NOMINATION	CORTE HORIZ. HORIZONT. DETAIL	CORTE VERT. VERTICALE DETAIL	QUANT. QUANTITY	CORTE GUT. COUPE
SO 12	ARO FIXO FIXED FRAME DORMANT	L	H	1+2	
SO 22	ARO FIXO SOLEIRA FIXED SILL FRAME SEUIL	L	-	1	
SO 66	ARO MÓVEL LATERAL MOBILE FR. OUVRANT	-	H-120 H-140	2	
SO 30	VARETA ROD PROFILE TIGE	-	VARIÁVEL VARIABLE VARIABLE	2	
OS 61	ARO MÓVEL CENTRAL PROFILE PROFILÉ	-	H-120 H-140	4	
OS 08	ARO MÓVEL MOBILE FR. OUVRANT	(L/3)-32	-	3	
OS 18	PERFIL REMATE PROFILE PROFILÉ	(L/3)-26.5 (L/3)-36.5)x2	-	2	
OS 40	PERFIL REMATE PROFILE PROFILÉ	(2L-265)/3	-	2	
OS 41	PERFIL REMATE PROFILE PROFILÉ	(L-125)/3	-	2	
OS 801	GUIA INF. INOX LOWER GUIDE GUIDE INFÉRIEUR	L-46	-	3	
OS 35	GUIA SUP. UPPER GUIDE GUIDE SUPÉRIEUR	L-46	-	3	
OS 95	POLIAMIDA POLYAMIDE POLYAMIDE	(2L-217)/3	H-74	2 + 4	
OS 30	PERFIL REMATE PROFILE PROFILÉ	(L/3)-44)x2	-	2	
OS 61	TAMPA DE CANAL TRACK COVER PROFILE CACHE CANAL	L/3-42	-	2	
SO 84	PERFIL SOLEIRA SILL PROFILE PROFILÉ DE SEUIL	-	H-79	2	
SO 25	PERFIL CALEIRA DRAINAGE CHANNEL GOUTTIERE DE VIDANGE	-	-	-	
SO 69	TAMPA DE CALEIRA DRAINAGE CHANNEL GRID GRILLE POUR GOUTTIERE DE VIDANGE	-	-	-	
VO 11	PERFIL FIXAÇÃO TAMPA DRAINAGE CHANNEL GRID FIX. PROF. PROF. FIXATION GRILLE	-	-	-	

CONSULTAR DEPARTAMENTO TÉCNICO
CONSULT TECHNICAL DEPARTMENT
CONSULTER DEPARTEMENT TECHNIQUE

(1) Peças com 400mm, aplicadas aproximadamente a cada 800mm | Pieces 400mm long, applied approximately every 800mm | Pièces de 400 mm, appliquées à environ tous les 800 mm

ACESSÓRIOS | ACCESSORIES | ACCESSOIRES

CODIGO CODE	DESIGNAÇÃO DESIGNATION NOMINATION	QUANTIDADE QUANTITY QUANTITE
205162	CARRINHO OS Nº5 ROLLER BEARING ROULEAU	6
205161	CARRINHO-GUIA OS SUPERIOR Nº3 UPPER-GUIDE ROLLER BEARING N3 ROULEAU-GUIDE SUPÉRIEUR N3	6
205172	ESQUADRO 18-2210-D BLOCKING BRACKET ÉQUERRE	16
213018	CANTO ALINHAMENTO OS N.2 ANGLE ANGLE	4
202323	CONTRA-FECHO OS INOX C/ AFINAÇÃO Nº2 COUNTER-LOCK BRACKET CONTRE-FERMETURE SUPPORT	6
213220	AMORTECEDOR OS N.3 SHOCK ABSORBER AMORTISSEUR	4
201089	FECHO LATERAL OS Nº4 N.4 LATERAL LOCK SERRURE LATÉRALE N.4	2
280000	TESTA OS-D P/FECHO OS N.2 STRIKING PLATE GÂCHE	6
215037	PEÇA AJUSTE P/FECHO LAT OS N.4 ADJUSTMENT PIECE PIÈCE DE RÉGLAGE	8
228166	MOLA PARA RETENÇÃO DE FECHO OS OS LOCK RETAINER SPRING RESSORT DE RETENUE POUR FERMETURE OS	2
210125	TOPO CENTRAL Nº6 OS-V2 SOL OCVLA ESQ CENTRAL END-CAP Nº6 OS-V2 LEFT EMBOUT CENTRAL Nº6 OS-V2 GAUCHE	4
210095	TOPO CENTRAL Nº2 OS-V2 DIREITO CENT. Nº2 RIGHT END-CAP EMBOUT CENT. Nº2 DROITE	4
210165	TOPO LATERAL SUP/INF Nº15 OS-V2 LAT. UPPER/LOWER Nº15 OS-V2 END-CAP EMBOUT LAT SUP/INF Nº15 OS-V2	2
210166	TOPO LAT. INF. 20mm Nº16 OS-V2 Sol. Invisível (OS 08) LAT. INF. 20mm Nº 16 END-CAP EMBOUT LAT. INF. 20mm Nº 16 ou (OS 08)	2
210167	TOPO LAT. INF. 40mm Nº17 OS-V2 Sol. Invisível (OS 18) LAT. INF. 40mm Nº 17 END-CAP EMBOUT LAT. INF. 40mm Nº 17	2
210159	TOPO ARO FIXO SOLEIRA OCULTA V2-N2 CONCEALED SILL FIXED FRAME END-CAP V2-N2 EMBOUT CADRE DORMANT SEUIL CACHÉ V2-N2	6
212066	CONJUNTO TOPOS OS 61 OS 61 END-CAP KIT KIT D'EMBOUT OS 61	4
213273	CORTA-VENTO OS SUPERIOR UPPER CENTRAL GASKET PIÈCE D'ÉTANCHEÏTE SUPÉRIEUR	2
213281	CORTA-VENTO SOL OCVLA OS 08 CONCEALED CENTRAL GASKET PIÈCE D'ÉTANCHEÏTE CACHÉE (OS 08) ou (OS 08)	2
213275	CORTA-VENTO SOL OCVLA OS 18 CONCEALED CENTRAL GASKET PIÈCE D'ÉTANCHEÏTE CACHÉE (OS 18)	2
210268	GOTEIRA C/ VÁLVULA SVE FLAP VALVE CLAPET À VOLET	DIVERSOS DIVERSES DIVERS
290020	PARAFUSO PAR 006 SCREW VIS	DIVERSOS DIVERSES DIVERS
215078	PEÇA ANTI-LEVANTAMENTO OS ANTI-LIFT ACCESSORY ANTI-LEVAGE ACCESSOIRE	2
215083	ANTI-LEVANTAMENTO GUIA INOX OS OS GUIDE ANTI-LIFT ACCESSORY ACCESSOIRE ANTI-LEVAGE POUR GUIDE	6
215194	CHAPA BLOQUEIO PELÚCIA PILE SEAL LOCK PLATE PLAQUE DE VERROUILLAGE DE JOINT BROSSÉ	4
210510	TOPO BLOQUEIO PELÚCIA CV1 PILE SEAL LOCK END-CAP CV1 EMBOUT DE VERROUILLAGE DE JOINT BROSSÉ CV1	4
212247	CONJ. TOPOS CAL/SOL OS-D 3-RAIL DRAINAGE CHANNEL/SILL OS-D 3-RAIL END-CAP KIT KIT D'EMBOUT DE GOUTTIERE/SEUIL OS-D 3-RAIL	1
210604	TAPA FUROS P/ AMORTECEDOR OS N.3 HOLE COVER FOR SHOCK ABSORBER N.3 COUVERCLE DE TROU POUR AMORTISSEUR N.3	2

* Opcional | Optional | Optionnel

VEDANTES | SEALENTS | JOINTS

CODIGO CODE	DESIGNAÇÃO DESIGNATION NOMINATION	QUANTIDADE QUANTITY QUANTITE
208450	PELÚCIA 7x5.5 Cinza PILE SEAL JOINT BROSSÉ	6L
208465	PELÚCIA 7x5.5 Preta PILE SEAL JOINT BROSSÉ	6L
208460	PELÚCIA 7x7 S-F PILE SEAL JOINT BROSSÉ	8H
208458	PELÚCIA 7x7 Cinza PILE SEAL JOINT BROSSÉ (OS 08 OS 18)	2L
208467	PELÚCIA 7x7 Preta PILE SEAL JOINT BROSSÉ (OS 08 OS 18)	2L
208468	PELÚCIA SRF 4x8 2P1M GRA Cinza PILE SEAL JOINT BROSSÉ	6L
208499	VD 2063.N	4H
208193	VD 2060	3L

JANELA DE CORRER 4 FOLHAS
4 SASHES SLIDING WINDOW
FENÊTRE COULISSANT 4 VANTAOX

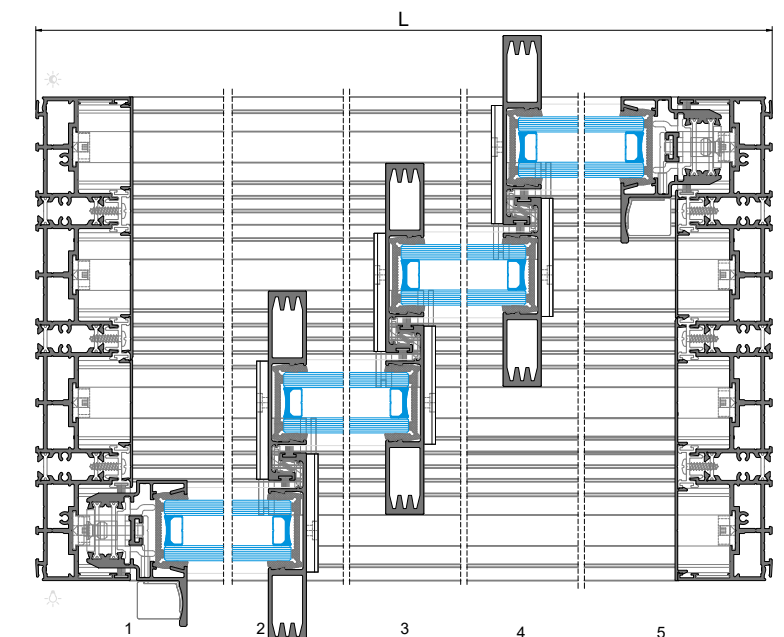
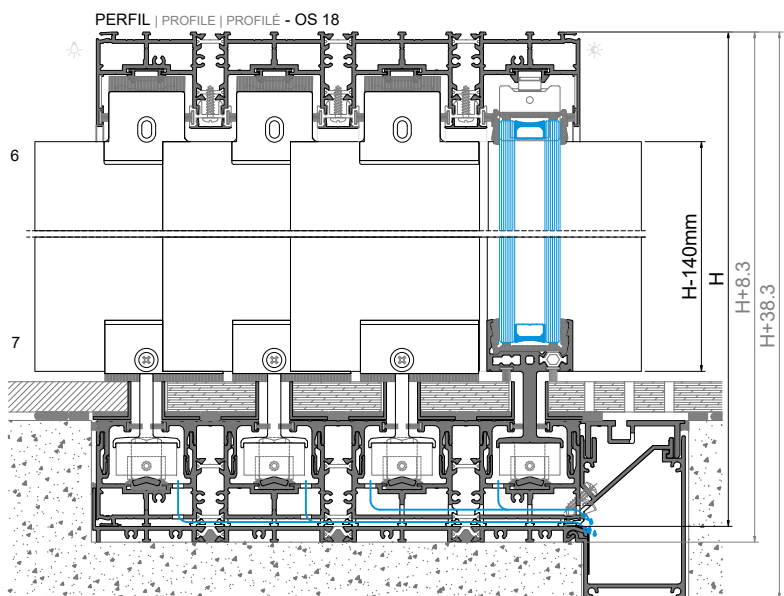
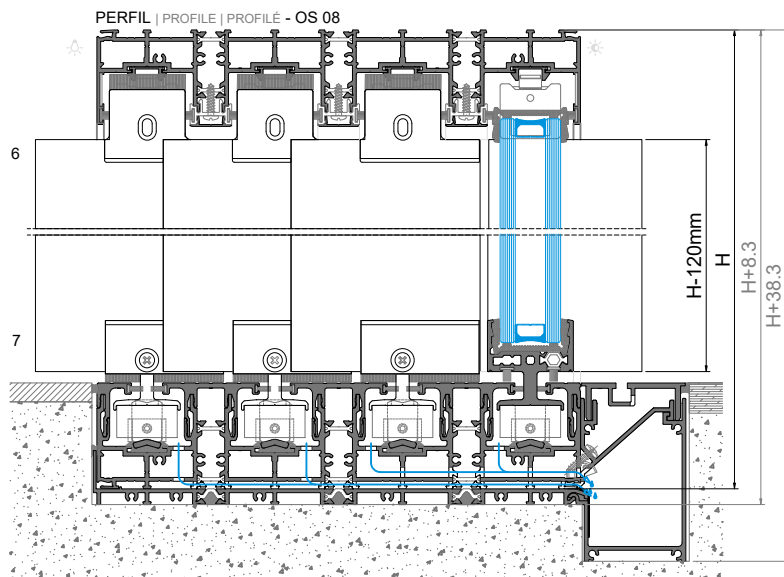
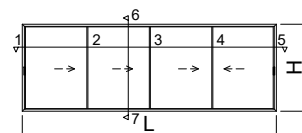

PERFIS PROFILES PROFILÉS					
CÓDIGO CODE	DESIGNAÇÃO DESIGNATION NOMINATION	CORTE HORIZ. HORIZONTAL DETAIL DETAIL HORIZONTAL	CORTE VERT. VERTICAL DETAIL DETAIL VERTICALE	QUANT. QUANTITY QUANTITE	CORTE CUT COUPE
		OS 08	OS 18		
OS 13	ARO FIXO FIXED FRAME DORMANT	L	H	1+2	
OS 23	ARO FIXO SOLEIRA FIXED SILL FRAME SEUIL	L	-	1	
SO 66	ARO MÓVEL LATERAL MOBILE FR. OUVRANT	-	H-120 H-140	2	
SO 30	VARETA ROD PROFILE TIGE	-	VARIÁVEL VARIABLE VARIABLE	2	
OS 61	ARO MÓVEL CENTRAL PROFILE PROFILE	-	H-120 H-140	6	
OS 08 OS 18	ARO MÓVEL MOBILE FR. OUVRANT	(L-85)/4	-	4	
OS 40	PERFIL REMATE PROFILE PROFILÉ	(L-80)/4 (3xL-340)/4	-	2	
OS 41	PERFIL REMATE PROFILE PROFILÉ	(3L-400)/4 (L-131)/2 (L-121)/4	-	2	
OS 801	GUIA INF. INOX LOWER GUIDE GUIDE INFÉRIEUR	L-46	-	4	
OS 35	GUIA SUP. UPPER GUIDE GUIDE SUPÉRIEUR	L-46	-	4	
OS 95	POLIAMIDA POLYAMIDE POLYAMIDE	(L-61)/4 (L-100)/2 (3xL-341)/4	H-74	2 2 + 6 2	
OS 30	PERFIL REMATE PROFILE PROFILÉ	(L-119)/4 (L-132)/2 (3xL-404)/4	-	2 2 2	
SO 63	TAMPA DE CANAL TRACK COVER PROFILÉ CACHE CANAL	-	H-79	2	
SO 61	TAMPA DE CANAL TRACK COVER PROFILÉ CACHE CANAL	-	H-79	2	
OS 83	PERFIL SOLEIRA SILL PROFILE PROFILÉ DE SEUIL	CONSULTAR DEPARTAMENTO TÉCNICO CONSULT TECHNICAL DEPARTMENT CONSULTER DÉPARTEMENT TECHNIQUE			
SO 25	PERFIL CALEIRA DRAINAGE CHANNEL GOUTTIÈRE DE VIDANGE				
SO 59	TAMPA DE CALEIRA DRAINAGE CHANNEL GRID GRILLE POUR GOUTTIÈRE DE VIDANGE				
VO 11	PERFIL FIXAÇÃO TAMPA DRAINAGE (1) CHANNEL GRID FIX. PROF. PROF. FIXATION GRILLE				

(1) Peças com 400mm, aplicadas aproximadamente a cada 800mm | Pieces 400mm long, applied approximately every 800mm | Pièces de 400 mm, appliquées à environ tous les 800 mm

ACESSÓRIOS ACCESSORIES ACCESSOIRES		
CÓDIGO CODE	DESIGNAÇÃO DESIGNATION NOMINATION	QUANTIDADE QUANTITY QUANTITE
205162	CARRINHO OS Nº5 ROLLER BEARING ROULEAU	8
205161	CARRINHO-GUIA OS SUPERIOR Nº3 UPPER-GUIDE ROLLER BEARING Nº3 ROULEAU-GUIDE SUPÉRIEUR Nº3	8
205172	ESQUADRO 18-2210-D BLOCKING BRACKET EQUERRE	16
213018	CANTO ALINHAMENTO OS N.2 ANGLE ANGLE	4
202323	CONTRA-FECHO OS INOX C/ AFINAÇÃO Nº2 COUNTER-LOCK BRACKET CONTRE-FERMETURE SUPPORT	6
213220	AMORTECEDOR OS N.3 SHOCK ABSORBER AMORTISSEUR	4
201089	FECHO LATERAL OS Nº4 N.4 LATERAL LOCK SERRURE LATÉRALE N.4	2
280000	TESTA OS-D P/FECHO OS N.2 STRIKING PLATE GÂCHE	6
215037	PEÇA AJUSTE P/FECHO LAT OS N.4 ADJUSTEMENT PIECE PIÈCE DE RÉGLAGE	8
228166	MOLA PARA RETENÇÃO DE FECHO OS OS LOCK RETAINER SPRING RESSORT DE RETENUE POUR FERMETURE OS	2
210125	TOPO CENTRAL Nº6 OS-V2 SOL OCULTA ESQ CENTRAL END-CAP Nº6 OS-V2 LEFT EMBOUT CENTRAL Nº6 OS-V2 GAUCHE	6
210095	TOPO CENTRAL Nº2 OS-V2 DIREITO CENT. Nº2 RIGHT END-CAP EMBOUT CENT. Nº2 DROITE	6
210165	TOPO LATERAL SUP/INF Nº15 OS-V2 LATERAL UPPER/LOWER Nº15 OS-V2 END-CAP LAT SUP/INF Nº15 OS-V2	2
210166	TOPO LAT. INF. 20mm Nº16 OS-V2 Sol. Invisível LAT. INF. 20mm Nº 16 END-CAP EMBOUT LAT. INF. 20mm Nº 16 (OS 08) ou or ou	2
210167	TOPO LAT. INF. 40mm Nº17 OS-V2 Sol. Invisível (OS 18) LAT. INF. 40mm Nº 17 END-CAP EMBOUT LAT. INF. 40mm Nº 17 (OS 18)	2
210159	TOPO ARO FIXO SOLEIRA OCULTA V2-N2 CONCEALED SILL FIXED FRAME END-CAP V2-N2 EMBOUT CADRE DORMANT SEUIL CACHÉ V2-N2	8
212066	CONJUNTO TOPOS OS 61 OS 61 END-CAP KIT KIT D'EMBOUT OS 61	6
213273	CORTA-VENTO OS SUPERIOR UPPER CENTRAL GASKET PIÈCE D'ÉTANCHÉITE SUPÉRIEUR	3
213281	CORTA-VENTO SOL OCULTA OS 08 CONCEALED CENTRAL GASKET PIÈCE D'ÉTANCHÉITE CACHÉE (OS 08) ou or ou	3
213275	CORTA-VENTO SOL OCULTA OS 18 CONCEALED CENTRAL GASKET PIÈCE D'ÉTANCHÉITE CACHÉE (OS 18)	3
210268	GOTEIRA C/ VÁLVULA SVE FLAP VALVE CLAPET À VOLET	DIVERSOS DIVERSES DIVERS
290020	PARAFUSO PAR 006 SCREW VIS	DIVERSOS DIVERSES DIVERS
215078	PEÇA ANTI-LEVANTAMENTO OS ANTI-LIFT ACCESSORY ANTI-LEVAGE ACCESSOIRE	2
215083	ANTI-LEVANTAMENTO GUIA INOX OS OS GUIDE ANTI-LIFT ACCESSORY ACCESSOIRE ANTI-LEVAGE POUR GUIDE	8
215194	CHAPA BLOQUEIO PELÚCIA PILE SEAL LOCK PLATE PLAQUE DE VERROUILLAGE DE JOINT BROSSE	6
210510	TOPO BLOQUEIO PELÚCIA CV PILE SEAL LOCK END-CAP CV EMBOUT DE VERROUILLAGE DE JOINT BROSSE CV	6
212251	CONJ. TOPOS CAL./SOL. OS-D 4-RAIL DRAINAGE CHANNEL/SILL OS-D 4-RAIL END-CAP KIT KIT D'EMBOUT DE GOUTTIÈRE/SEUIL OS-D 4-RAIL	1
210604	TAPA FUROS P/ AMORTECEDOR OS N.3 HOLE COVER FOR SHOCK ABSORBER N.3 COUVERCLE DE TROU POUR AMORTISSEUR N.3	2

* Opcional | Optional | Optionnel

VEDANTES SEALENTS JOINTS		
CÓDIGO CODE	DESIGNAÇÃO DESIGNATION NOMINATION	QUANTIDADE QUANTITY QUANTITE
208450 ou or ou 208465	PELÚCIA 7x5.5 Cinza PILE SEAL JOINT BROSSE	8L
208460	PELÚCIA 7x7 S-F PILE SEAL JOINT BROSSE	10H
208458 ou or ou 208467	PELÚCIA 7x7 Cinza PILE SEAL JOINT BROSSE (OS 08 OS 18)	2L
208468	PELÚCIA SRF 4x8 2P1M GRA Cinza PILE SEAL JOINT BROSSE	8L
208499	VD 2063.N	6H
208193	VD 2060	4L

JANELA DE CORRER DE EMBUTIR COM 1 FOLHA
1SASH POCKET SLIDING WINDOW
FENÊTRE COULISSANT À GALANDAGE 1 VANTAIL

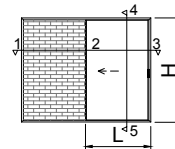

PERFIL | PROFILE | PROFILÉ - OS 08

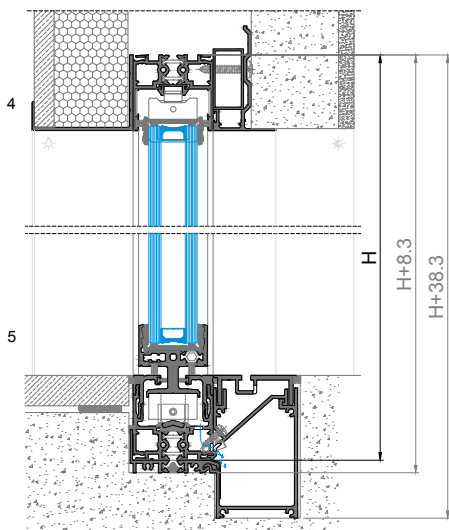

PERFIL | PROFILE | PROFILÉ - OS 18

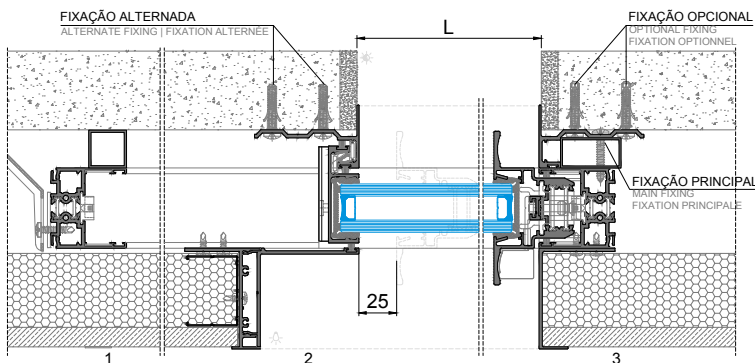
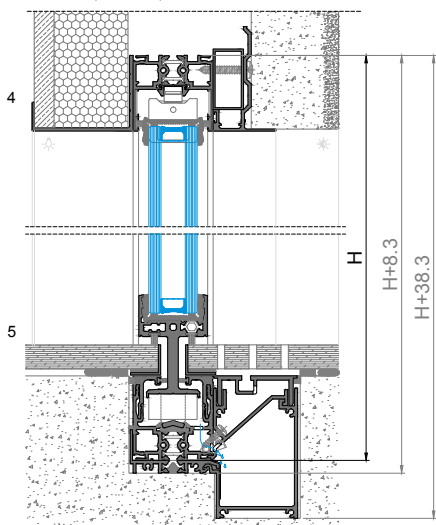

PERFIS PROFILES PROFILÉS					
CODIGO CODE	DESIGNAÇÃO DESIGNATION / NOMINATION	CORTE HORIZ. HORIZONTAL DETAIL	CORTE VERT. VERTICAL DETAIL	QUANT. QUANTITY	CORTE CUT / COUPE
			OS 08 OS 18		
SO 14	ARO FIXO FIXED FRAME DORMANT	(Lx2)+65	H	1+2	
SO 24	ARO FIXO SOLEIRA FIXED SILL FRAME SEUIL	(Lx2)+65	-	1	
SO 65	ARO MÓVEL LATERAL MOBILE FR. OUVRANT	-	H-120 H-140	1	
SO 30	VARETA ROD PROFILE TIGE	-	VARIÁVEL VARIABLE / VARIABLE	1	
OS 11	ARO MÓVEL CENTRAL PROFILE PROFILÉ	-	H-120 H-140	1	
OS 08 OS 18	ARO MÓVEL MOBILE FR. OUVRANT	L+1	-	1	
OS 40	PERFIL REMATE PROFILE PROFILÉ	L+22	-	2	
OS 801	GUIA INF. INOX LOWER GUIDE GUIDE INFÉRIEUR	(Lx2)+19	-	1	
OS 35	GUIA SUP. UPPER GUIDE GUIDE SUPÉRIEUR	(Lx2)+19	-	1	
SO 45	PERFIL REMATE PROFILE PROFILÉ				CONSULTAR DEPARTAMENTO TÉCNICO CONSULT TECHNICAL DEPARTMENT CONSULTER DÉPARTEMENT TECHNIQUE
SO 46	PERFIL REMATE PROFILE PROFILÉ				
SO 47	PERFIL REMATE PROFILE PROFILÉ				
SO 48	PERFIL REMATE PROFILE PROFILÉ				
KQ 25	PERFIL REMATE PROFILE PROFILÉ				
KP 42	PERFIL REMATE PROFILE PROFILÉ				
SO 80	PERFIL SOLEIRA SILL PROFILE PROFILÉ DE SEUIL				
SO 25	PERFIL CALEIRA DRAINAGE CHANNEL GOUTTIÈRE DE VIDANGE				
SO 59	TAMPA DE CALEIRA DRAINAGE CHANNEL GRID GRILLE POUR GOUTTIÈRE DE VIDANGE				
VO 11	PERFIL FIXAÇÃO TAMPA DRAINAGE CHANNEL GRID FIX. PROF. PROF. FIXATION GRILLE				

(1) Peças com 400mm, aplicadas aproximadamente a cada 800mm | Pieces 400mm long, applied approximately every 800mm | Pièces de 400 mm, appliquées à environ tous les 800 mm

ACESSÓRIOS ACCESSORIES ACCESSOIRES		
CÓDIGO CODE	DESIGNAÇÃO DESIGNATION / NOMINATION	QUANTIDADE QUANTITY / QUANTITÉ
205162	CARRINHO OS N°5 ROLLER BEARING ROULEAU	2
205161	CARRINHO-GUIA OS SUPERIOR N°3 ROLLER-BEARING N°3 ROULEAU-GUIDE SUPÉRIEUR N°3	2
205173	ESQUADRO 18-1310-C BLOCKING BRACKET ÉQUERRE	8
213018	CANTO ALINHAMENTO OS N.2 ANGLE ANGLE	4
202323	CONTRA-FECHO OS INOX C/ AFINAÇÃO N°2 COUNTER-LOCK BRACKET / CONTRE-FERMETURE SUPPORT	3
213220	AMORTECEDOR OS N.3 SHOCK ABSORBER AMORTISSEUR	2
201089	FECHO LATERAL OS N°4 N°4 LATERAL LOCK SERRURE LATÉRALE N.4	1
280000	TESTA OS-D P/FECHO OS N.2 STRIKING PLATE GÂCHE	3
215037	PEÇA AJUSTE P/FECHO LAT OS N.4 ADJUSTMENT PIECE / PIÈCE DE RÉGLAGE	4
228166	MOLA PARA RETENÇÃO DE FECHO OS OS LOCK RETAINER SPRING / RESSORT DE RETENUE POUR FERMETURE OS	1
210094	TOPO CENTRAL N°2 OS-V2 ESQUERDO CENTRAL UPPER/LAT. END-CAP / EMBOUT CENTRAL V2 GAUCHE	1
210126	TOPO CENTRAL N°6 OS-V2 SOL. OCULTA DIREITO CENT. N°6 RIGHT CONC. SILL END-CAP / EMBOUT CENT. N°6 SEUIL CACHÉ DROITE	1
210165	TOPO LATERAL SUP/INF N°15 OS-V2 LATERAL UPPER/LOWER N°15 OS-V2 END-CAP / EMBOUT LAT SUP/INF N°15 OS-V2	1
210166	TOPO LAT. INF. 20mm N°16 OS-V2 Sol. Invisível (OS 08) LAT. INF. 20mm N°16 END-CAP / EMBOUT LAT. INF. 20mm N°16 ou or ou	1
210167	TOPO LAT. INF. 40mm N°17 OS-V2 Sol. Invisível (OS 18) LAT. INF. 40mm N°17 END-CAP / EMBOUT LAT. INF. 40mm N°17	1
210159	TOPO ARO FIXO SOLEIRA OCULTA V2-N2 CONCEALED SILL FIXED FRAME END-CAP V2-N2 / EMBOUT CADRE DORMANT SEUIL CACHÉ V2-N2	1
210268	GOTEIRA C/ VÁLVULA SVE FLAP VALVE / CLAPET À VOLET	DIVERSOS DIVERSES / DIVERS
290020	PARAFUSO PAR 006 SCREW / VIS	DIVERSOS DIVERSES / DIVERS
215078	PEÇA ANTI-LEVANTAMENTO OS ANTI-LIFT ACCESSORY / ANTI-LEVAGE ACCESSOIRE	1
215083	ANTI-LEVANTAMENTO GUIA INOX OS OS GUIDE ANTI-LIFT ACCESSORY / ACCESSOIRE ANTI-LEVAGE POUR GUIDE	2
215194	CHAPA BLOQUEIO PELÚCIA PILE SEAL LOCK PLATE / PLAQUE DE VERROUILLAGE DE JOINT BROSSÉ	2
212245	CONJ. TOPOS CAL / SOL. OS-D 1-RAIL DRAINAGE CHANNEL/SILL OS-D 1-RAIL END-CAP KIT / KIT EMBOUT DE GOUTTIÈRE/SEUIL OS-D 1-RAIL	1
210604	TAPA FUROS P/ AMORTECEDOR OS N.3 HOLE COVER FOR SHOCK ABSORBER N.3 / COUVERCLE DE TROU POUR AMORTISSEUR N.3	1

VEDANTES SEALENTS JOINTS		
CÓDIGO CODE	DESIGNAÇÃO DESIGNATION / NOMINATION	QUANTIDADE QUANTITY / QUANTITÉ
208450 ou or ou 208465	PELÚCIA 7x5.5 Cinza PILE SEAL / JOINT BROSSÉ ou or ou PELÚCIA 7x5.5 Preta PILE SEAL / JOINT BROSSÉ	4L
208460	PELÚCIA 7x7 S-F PILE SEAL / JOINT BROSSÉ	5H
208458 ou or ou 208467	PELÚCIA 7x7 Cinza PILE SEAL / JOINT BROSSÉ (OS 08 OS 18) ou or ou PELÚCIA 7x7 Preta PILE SEAL / JOINT BROSSÉ (OS 08 OS 18)	2L
208468	PELÚCIA SRF 4x8 2P1M Cinza PILE SEAL / JOINT BROSSÉ	2L
208499	VD 2063.N	2H
208193	VD 2060	2L

JANELA DE CORRER DE EMBUTIR COM 1 FOLHA 2-RAIL
1 SASH 2-RAIL POCKET SLIDING WINDOW
FENÊTRE COULISSANT À GALANDAGEÀ 1 VANTAIL 2-RAIL

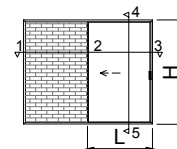

PERFIL | PROFILE | PROFILÉ - OS 08

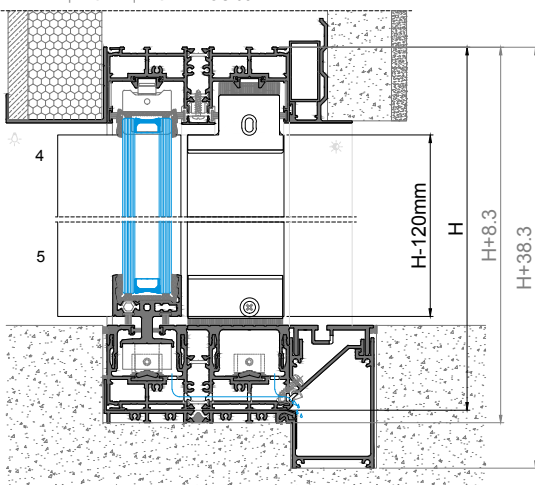

PERFIL | PROFILE | PROFILÉ - OS 18

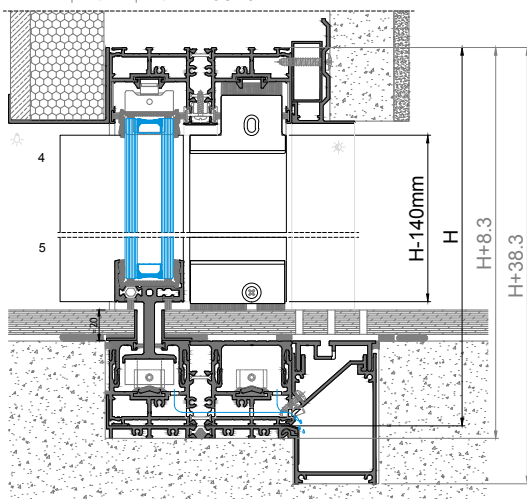

FIXAÇÃO ALTERNADA
ALTERNATE FIXING
FIXATION ALTERNÉE

FIXAÇÃO PRINCIPAL
MAIN FIXING
FIXATION PRINCIPALE

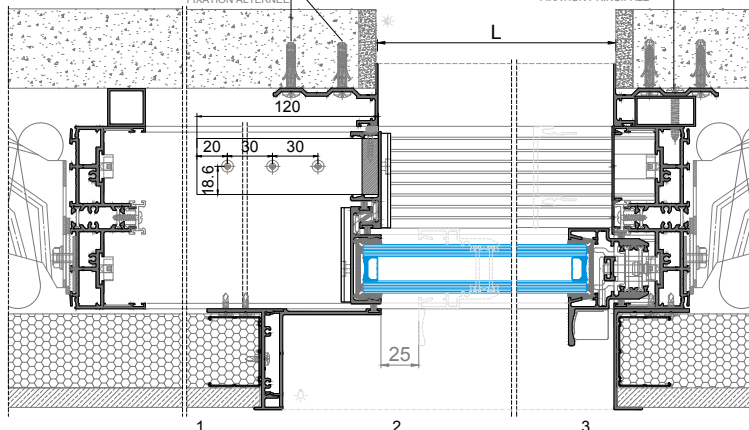

PERFIS | PROFILES | PROFILÉS

CODIGO CODE	DESIGNAÇÃO DESIGNATION NOMINATION	CORTE HORIZ. HORIZONTAL DETAIL BETAIL HORIZONTAL	CORTE VERT. VERTICAL DETAIL BETAIL VERTICALE	QUANT. QUANTITY QUANTITE	CORTE CUT COUPE
SO 11	ARO FIXO FIXED FRAME DORMANT				
SO 21	ARO FIXO SOLEIRA FIXED SILL FRAME SEUIL				
SO 66	ARO MÓVEL LATERAL MOBILE FR. OUVRANT				
SO 30	VARETA ROD PROFILE TIGE				
OS 11	ARO MÓVEL CENTRAL PROFILE PROFILÉ				
OS 08 OS 18	ARO MÓVEL MOBILE FR. OUVRANT				
OS 40	PERFIL REMATE PROFILE PROFILÉ				
SO 71	PERFIL REMATE PROFILE PROFILÉ				
OS 801	GUIA INF. INOX LOWER GUIDE GUIDE INFÉRIEUR				
OS 35	GUIA SUP. UPPER GUIDE GUIDE SUPÉRIEUR				
OS 95	POLIAMIDA POLYAMIDE POLYAMIDE				
OS 30	PERFIL REMATE PROFILE PROFILÉ				
SO 60	TAMPA DE CANAL TRACK COVER PROFILE CACHE CANAL				
SO 45	PERFIL REMATE PROFILE PROFILÉ				
SO 46	PERFIL REMATE PROFILE PROFILÉ				
SO 47	PERFIL REMATE PROFILE PROFILÉ				
SO 48	PERFIL REMATE PROFILE PROFILÉ				
KQ 25	PERFIL REMATE PROFILE PROFILÉ				
KP 42	PERFIL REMATE PROFILE PROFILÉ				
SO 82	PERFIL SOLEIRA SILL PROFILE PROFILÉ DE SEUIL				
SO 25	PERFIL CALEIRA DRAINAGE CHANNEL GOUTTIERE DE VIDANGE				
SO 59	TAMPA DE CALEIRA DRAINAGE CHANNEL GRID GRILLE POUR SCOUTTIERE DE VIDANGE				
VO 11	PERFIL FIXAÇÃO TAMPA DRAINAGE (1) CHANNEL GRID FIX. PROF. PROF. FIXATION GRILLE				

CONSULTAR DEPARTAMENTO TÉCNICO
CONSULT TECHNICAL DEPARTMENT
CONSULTER DEPARTEMENT TECHNIQUE

(1) Peças com 400mm, aplicadas aproximadamente a cada 800mm | Pieces 400mm long, applied approximately every 800mm | Pièces de 400 mm, appliquées à environ tous les 800 mm

ACESSÓRIOS | ACCESSORIES | ACCESSOIRES

CODIGO CODE	DESIGNAÇÃO DESIGNATION NOMINATION	QUANTIDADE QUANTITY QUANTITE
205162	CARRINHO OS N°5 ROLLER BEARING ROULEAU	2
205161	CARRINHO-GUIA OS SUPERIOR N°3 UPPER-GUIDE ROLLER BEARING N3 ROULEAU-GUIDE SUPÉRIEUR N3	2
205172	ESQUADRO 18-2210-D BLOCKING BRACKET ÉQUERRE	8
213018	CANTO ALINHAMENTO OS N.2 ANGLE ANGLE	4
202323	CONTRA-FECHO OS INOX C/ AFINAÇÃO N°2 COUNTER-LOCK BRACKET CONTRE-FERMETURE SUPPORT	3
213220	AMORTECEDOR OS N.3 SHOCK ABSORBER AMORTISSEUR	2
201089	FECHO LATERAL OS N°4 N.4 LATERAL LOCK SERRURE LATÉRALE N.4	1
280000	PESTA OS-D P/FECHO OS N.2 STRIKING PLATE GÂCHE	3
215037	PEÇA AJUSTE P/FECHO LAT OS N.4 ADJUSTMENT PIECE PIÈCE DE REGLAGE	4
228186	MOLA PARA RETENÇÃO DE FECHO OS OS SPRING FOR RETENTION OF LOCK FOR FERMETURE OS	1
210126	TOPO CENTRAL N°6 OS-V2 SOL. OCULTA DIREITO CENT. N°6 RIGHT CONC. SILL END-CAP EMBOUT CENT. N°6 SEUIL CACHÉ DROITE	2
210094	TOPO CENTRAL N°2 OS-V2 ESQUERDO CENTRAL N°2 LEFT END-CAP EMBOUT CENTRAL N°2 GAUCHE	2
210165	TOPO LATERAL SUP/INF N°15 OS-V2 LATERAL UPPER/LOWER END-CAP N°15 OS-V2 END-CAP LAT SUP/INF N°15 OS-V2	1
210166	TOPO LAT. INF. 20mm N°16 OS-V2 Sol. Invisível LAT. INF. 20mm N°16 END-CAP EMBOUT LAT. INF. 20mm N°16 (OS 08)	1
210167	TOPO LAT. INF. 40mm N°17 OS-V2 Sol. Invisível LAT. INF. 40mm N°17 END-CAP EMBOUT LAT. INF. 40mm N°17 (OS 18)	1
210169	TOPO ARO FIXO SOLEIRA OCULTA V2-N2 CONCEALED SILL FIXED FRAME END-CAP V2-N2 EMBOUT CADRE DORMANT SEUIL CACHÉ V2-N2	2
213273	CORTA-VENTO OS SUPERIOR UPPER CENTRAL GASKET PIÈCE D'ÉTANCHÉITE SUPÉRIEUR	1
210268	GOTEIRA C/ VÁLVULA SVE FLAP VALVE CLAPET À VOLET	DIVERSOS DIVERSES DIVERS
290020	PARAFUSO PAR 006 SCREW VIS	DIVERSOS DIVERSES DIVERS
215078	PEÇA ANTI-LEVANTAMENTO OS ANTI-LIFT ACCESSORY ANTI-LEVAGE ACCESSOIRE	1
215083	ANTI-LEVANTAMENTO GUIA INOX OS OS GUIDE ANTI-LIFT ACCESSORY ACCESSOIRE ANTI-LEVAGE POUR GUIDE	4
215194	CHAPA BLOQUEIO PELÚCIA PILE SEAL LOCK PLATE PLAQUE DE VERROUILLAGE DE JOINT BROSSÉ	1
210510	TOPO BLOQUEIO PELÚCIA CV PILE SEAL LOCK END-CAP CV EMBOUT DE VERROUILLAGE DE JOINT BROSSÉ CV	1
212246	CONJ. TOPOS CAL/SOL OS-D 2-RAIL DRAINAGE CHANNEL/SILL OS-D 2-RAIL END-CAP KIT KIT D'EMBOUT DE GOUTTIERE/SEUIL OS-D 2-RAIL	1
210604	TAPA FUROS P/ AMORTECEDOR OS N.3 HOLE COVER FOR SHOCK ABSORBER N.3 COUVERCLE DE TROU POUR AMORTISSEUR N.3	1

VEDANTES | SEALENTS | JOINTS

CODIGO CODE	DESIGNAÇÃO DESIGNATION NOMINATION	QUANTIDADE QUANTITY QUANTITE
208450 ou or ou	PELÚCIA 7x5.5 Cinza PILE SEAL JOINT BROSSÉ	4L
208465	PELÚCIA 7x5.5 Preta PILE SEAL JOINT BROSSÉ	
208460	PELÚCIA 7x7 S-F PILE SEAL JOINT BROSSÉ	5H
208458 ou or ou	PELÚCIA 7x7 Cinza PILE SEAL JOINT BROSSÉ (OS 08 OS 18)	2L
208467	PELÚCIA 7x7 Preta PILE SEAL JOINT BROSSÉ (OS 08 OS 18)	
208468	PELÚCIA SRF 4x8 2P1M GRA Cinza PILE SEAL JOINT BROSSÉ	2L
208499	VD 2063.N	2H
208193	VD 2060	2L

JANELA DE CORRER DE EMBUTIR COM 2 FOLHAS 2-RAIL
2 SASHES 2-RAIL POCKET SLIDING WINDOW
FENÊTRE COULISSANT À GALANDAGE À 2 VANTAOX 2-RAIL

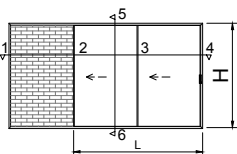

PERFIL | PROFILE | PROFILÉ - OS 08

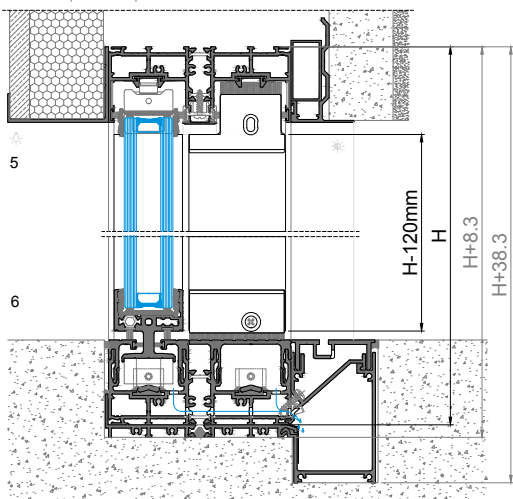

PERFIL | PROFILE | PROFILÉ - OS 18

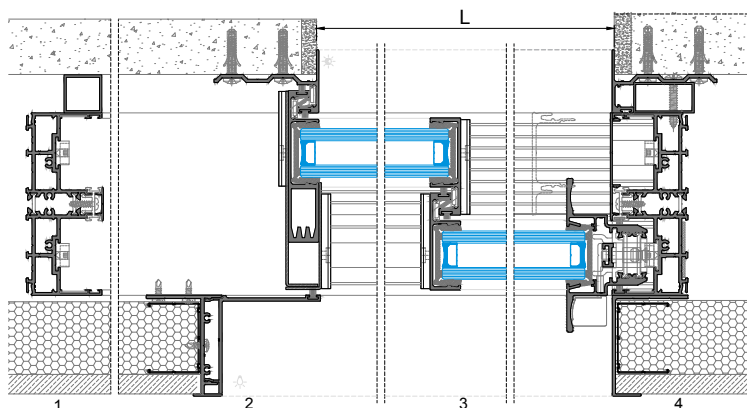
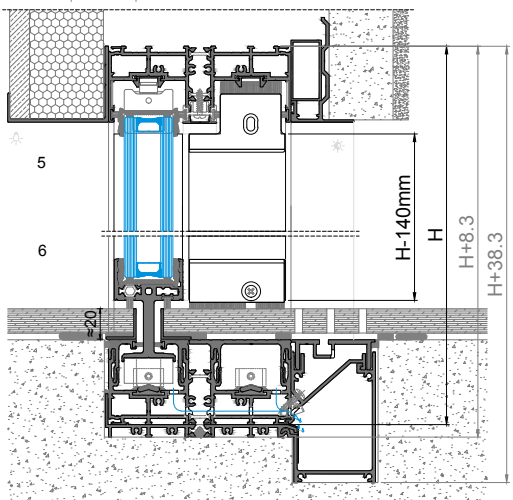

PERFIS PROFILES PROFILÉS					
CÓDIGO CODE	DESIGNAÇÃO DESIGNATION NOMINATION	CORTE HORIZ. HORIZONTAL DETAIL	CORTE VERT. VERTICAL DETAIL	QUANT. QUANTITY	CORTE CUT
SO 11	ARO FIXO FIXED FRAME DORMANT				
SO 21	ARO FIXO SOLEIRA FIXED SILL FRAME SEUIL				
SO 65	ARO MÓVEL LATERAL MOBILE FR. OUVRANT				
SO 30	VARETA ROD PROFILE TIGE				
OS 11	ARO MÓVEL CENTRAL PROFILE PROFILÉ				
OS 61	ARO MÓVEL CENTRAL PROFILE PROFILÉ				
OS 08	ARO MÓVEL MOBILE FR. OUVRANT				
OS 18	ARO MÓVEL MOBILE FR. OUVRANT				
OS 40	PERFIL REMATE PROFILE PROFILÉ				
SO 71	PERFIL REMATE PROFILE PROFILÉ				
OS 801	GUIA INF. INOX LOWER GUIDE GUIDE INFÉRIEUR				
OS 35	GUIA SUP. UPPER GUIDE GUIDE SUPÉRIEUR				
OS 95	POLIAMIDA POLYAMIDE POLYAMIDE				
OS 30	PERFIL REMATE PROFILE PROFILÉ				
SO 80	TAMPA DE CANAL TRACK COVER PROFILÉ CACHE CANAL				
SO 45	PERFIL REMATE PROFILE PROFILÉ				
SO 46	PERFIL REMATE PROFILE PROFILÉ				
SO 47	PERFIL REMATE PROFILE PROFILÉ				
SO 48	PERFIL REMATE PROFILE PROFILÉ				
KQ 25	PERFIL REMATE PROFILE PROFILÉ				
KP 42	PERFIL REMATE PROFILE PROFILÉ				
SO 82	PERFIL SOLEIRA SILL PROFILE PROFILÉ DE SEUIL				
SO 25	PERFIL CALEIRA DRAINAGE CHANNEL GOUTTIÈRE DE VIDANGE				
SO 59	TAMPA DE CALEIRA DRAINAGE CHANNEL GRID GRILLE POUR GOUTTIÈRE DE VIDANGE				
VO 11	PERFIL FIXAÇÃO TAMPA DRAINAGE (1) CHANNEL GRID FIX. PROF. PROF. FIXATION GRILLE				

CONSULTAR DEPARTAMENTO TÉCNICO
CONSULT TECHNICAL DEPARTMENT
CONSULTER DÉPARTEMENT TECHNIQUE

(1) Peças com 400mm, aplicadas aproximadamente a cada 800mm | Pieces 400mm long, applied approximately every 800mm | Pièces de 400 mm, appliquées à environ tous les 800 mm

ACESSÓRIOS ACCESSORIES ACCESSOIRES			
CÓDIGO CODE	DESIGNAÇÃO DESIGNATION NOMINATION	QUANTIDADE QUANTITY QUANTITÉ	
205162	CARRINHO OS Nº5 ROLLER BEARING ROULEAU	4	
205161	CARRINHO-GUIA OS SUPERIOR Nº3 UPPER-GUIDE ROLLER BEARING N3 ROULEAU-GUIDE SUPÉRIEUR N3	4	
205172	ESQUADRO 18-2210-D BLOCKING BRACKET ÉQUERRE	8	
213018	CANTO ALINHAMENTO OS N.2 ANGLE ANGLE	4	
202323	CONTRA-FECHO OS INOX C/ AFINAÇÃO Nº2 COUNTER-LOCK BRACKET CONTRE-FERMETURE SUPPORT	3	
213220	AMORTECEDOR OS N.3 SHOCK ABSORBER AMORTISSEUR	2	
201089	FECHO LATERAL OS Nº4 N.4 LATERAL LOCK SERRURE LATÉRALE N.4	1	
280000	TESTA OS-D P/FECHO OS N.2 STRIKING PLATE GÂCHE	3	
215037	PEÇA AJUSTE P/FECHO LAT OS N.4 ADJUSTMENT PIECE PIÈCE DE RÉGLAGE	4	
228186	MOLA PARA RETENÇÃO DE FECHO OS OS LOCK RETAINER SPRING RESSORT DE RETENUE POUR FERMETURE OS	1	
210125	TOPO CENTRAL Nº6 OS-V2 SOL OCULTA ESQ CENTRAL END-CAP Nº6 OS-V2 LEFT EMBOUT CENTRAL Nº6 OS-V2 GAUCHE	2	
210095	TOPO CENTRAL Nº2 OS-V2 DIREITO CENT. Nº2 RIGHT END-CAP EMBOUT CENT. Nº2 DROITE	2	
210165	TOPO LATERAL SUP/INF Nº15 OS-V2 LAT. SUP/INF END-CAP Nº15 OS-V2 END-CAP EMBOUT LAT SUP/INF Nº15 OS-V2	1	
210166	TOPO LAT. INF. 20mm Nº16 OS-V2 Sol. Invisível LAT. INF. 20mm Nº16 END-CAP EMBOUT LAT. INF. 20mm Nº16 (OS 08) ou or ou	1	
210167	TOPO LAT. INF. 40mm Nº17 OS-V2 Sol. Invisível LAT. INF. 40mm Nº17 END-CAP EMBOUT LAT. INF. 40mm Nº17 (OS 18) ou or ou	1	
210159	TOPO ARO FIXO SOLEIRA OCULTA V2-N2 CONCEALED SILL FIXED FRAME END-CAP V2-N2 EMBOUT CADRE DORMANT SEUIL CACHÉ V2-N2	2	
213273	CORTA-VENTO OS SUPERIOR UPPER CENTRAL GASKET PIÈCE D'ÉTANCHÉITE SUPÉRIEUR	1	
213281	CORTA-VENTO SOL OCULTA OS 08 CONCEALED CENTRAL GASKET PIÈCE D'ÉTANCHÉITE CACHÉE (OS 08) ou or ou	1	
213275	CORTA-VENTO SOL OCULTA OS 18 CONCEALED CENTRAL GASKET PIÈCE D'ÉTANCHÉITE CACHÉE (OS 18)	1	
210268	GOTEIRA C/ VÁLVULA SVE FLAP VALVE CLAPET À VOILET	DIVERSOS DIVERSES DIVERS	
290020	PARAFUSO PAR 006 SCREW VIS	DIVERSOS DIVERSES DIVERS	
215078	PEÇA ANTI-LEVANTAMENTO OS ANTI-LIFT ACCESSORY ANTI-LEVAGE ACCESSOIRE	1	
215083	ANTI-LEVANTAMENTO GUIA INOX OS OS GUIDE ANTI-LIFT ACCESSORY ACCESSOIRE ANTI-LEVAGE POUR GUIDE	4	
215194	CHAPA BLOQUEIO PELÚCIA PILE SEAL LOCK PLATE PLAQUE DE VERROUILLAGE DE JOINT BRASSE	2	
210510	TOPO BLOQUEIO PELÚCIA CV PILE SEAL LOCK END-CAP CV EMBOUT DE VERROUILLAGE DE JOINT BRASSE CV	2	
212246	CONJ. TOPOS CAL./SOL OS-D 2-RAIL DRAINAGE CHANNEL/SILL OS-D 2-RAIL END-CAP KIT EMBOUT DE GOUTTIÈRE/SEUIL OS-D 2-RAIL	1	
210604	TAPA FUROS P/ AMORTECEDOR OS N.3 HOLE COVER FOR SHOCK ABSORBER N.3 COUVERCLE DE TROU POUR AMORTISSEUR N.3	1	

VEDANTES SEALENTS JOINTS			
CÓDIGO CODE	DESIGNAÇÃO DESIGNATION NOMINATION	QUANTIDADE QUANTITY QUANTITÉ	
208450 ou or ou	208450 ou or ou	4L	
208465	208465	7H	
208460	208460	2L	
208458 ou or ou	208458 ou or ou	2L	
208467	208467	2L	
208468	208468	2H	
208499	208499	4L	
208193	208193		

JANELA DE CORRER 2 FOLHAS - COM 2 FECHADURAS - (vidros iguais)
2 SASHES SLIDING WINDOW - WITH 2 LOCKS - (glasses with equal widths)
FENÊTRE COULISSANT 2 VANTAOX - AVEC 2 SERRURES - (verres de même largeurs)

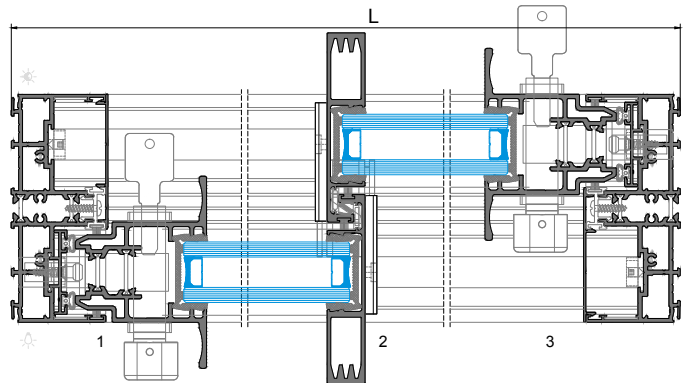
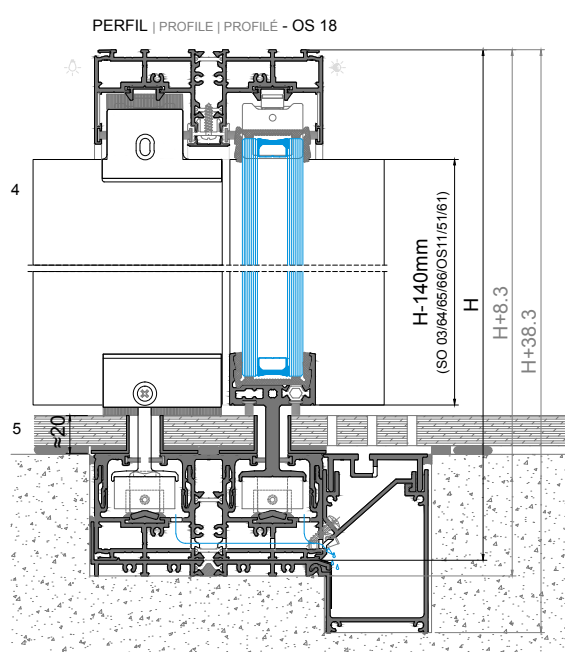
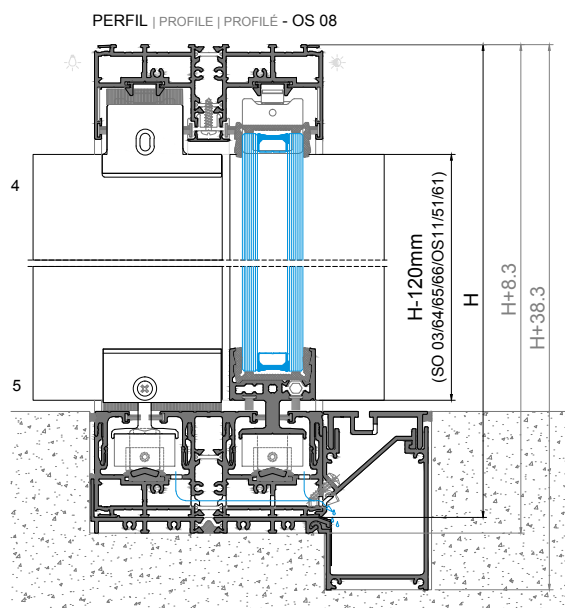
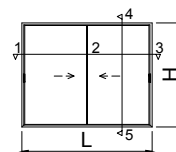

PERFIS PROFILES PROFILÉS						
CODIGO CODE	DESIGNAÇÃO DESIGNATION / NOMINATION	CORTE HORIZ. HORIZONT. DETAIL	CORTE VERT. VERTIC. DETAIL	QUANT. QUANTITY	CORTE COUPE	
SO 11	ARO FIXO FIXED FRAME DORMANT	L	H	1+2		
SO 21	ARO FIXO SOLEIRA FIXED SILL FRAME SEUIL	L	-	1		
SO 03	ARO MÓVEL LATERAL/ FECHADURA LATERAL LOCK PROFILE / JOUVRANT LAT. SERRURE	-	H-120 H-140	2		
SO 40	PERFIL TESTA FECHADURA LOCK PLATE PROFILE / PROFILÉ POUR SERRURE	-	H-80 H-100	2		
OS 61	ARO MÓVEL CENTRAL PROFILE PROFILÉ	-	H-120 H-140	2		
OS 08 OS 18	ARO MÓVEL MOBILE FR. JOUVRANT	(L/193)-2	-	2		
OS 40	PERFIL REMATE PROFILE PROFILÉ	(L/2)-50,5	-	4		
OS 41	PERFIL REMATE PROFILE PROFILÉ	(L/2)65,5	-	2		
OS 801	GUIA INF. INOX LOWER GUIDE / GUIDE INFÉRIEUR	L-46	-	2		
OS 35	GUIA SUP. UPPER GUIDE / GUIDE SUPÉRIEUR	L-46	-	2		
OS 95	POLIAMIDA POLYAMIDE POLYAMIDE	(L/2)-50	H-74	2+2		
OS 30	PERFIL REMATE PROFILE PROFILÉ	(L/2)-65	-	2		
OS 60	TAMPA DE CANAL TRACK COVER / PROFILE CACHE CANAL	-	H-79	2		
SO 82	PERFIL SOLEIRA SILL PROFILE / PROFILÉ DE SEUIL	CONSULTAR DEPARTAMENTO TÉCNICO CONSULT TECHNICAL DEPARTMENT CONSULTER DÉPARTEMENT TECHNIQUE				
SO 25	PERFIL CALEIRA DRAINAGE CHANNEL / GOUTTIÈRE DE VIDANGE					
SO 69	TAMPA DE CALEIRA DRAINAGE CHANNEL GRID / GRILLE POUR GOUTTIÈRE DE VIDANGE					
VO 11	PERFIL FIXAÇÃO TAMPA DRAINAGE CHANNEL GRID FIX. PROF. / PROF. FIXATION GRILLE					

(1) Peças com 400mm, aplicadas aproximadamente a cada 800mm | Pieces 400mm long, applied approximately every 800mm | Pièces de 400 mm, appliquées à environ tous les 800 mm

ACESSÓRIOS ACCESSORIES ACCESSOIRES		
CODIGO CODE	DESIGNAÇÃO DESIGNATION / NOMINATION	QUANTIDADE QUANTITY / QUANTITÉ
205162	CARRINHO OS N°5 ROLLER BEARING / ROULEAU	4
205161	CARRINHO-GUIA OS SUPERIOR N°3 UPPER-GUIDE ROLLER BEARING N3 / ROULEAU-GUIDE SUPÉRIEUR N3	4
205172	ESQUADRO 18-2210-D BLOCKING BRACKET / ÉQUERRE	8
213018	CANTO ALINHAMENTO OS N.2 ANGLE / ANGLE	4
	FECHADURA 3 PONTOS LOCK / SERRURE	* 2
213220	AMORTECEDOR OS N.3 SHOCK ABSORBER / AMORTISSEUR	4
280037	TESTA FECHADURA OS N.2 STRIKING PLATE / GÂCHE	6
290105	PARAFUSO DIN7982 8x3/4 INOX A2 SCREW / VIS	12
203306	COPO PARA TESTA FECHADURA RECESSED LOCK END-CAP / EMBOUT A ENCASTRER POUR SERRURE	6
	CILINDRO CYLINDER / CYLINDRE	* 2
220196	ESPELHO 23MM CYLINDER / CYLINDRE	4
210125	TOPO CENTRAL N°6 OS-V2 SOL OCULTA ESQ CENTRAL END-CAP N°6 OS-V2 LEFT / EMBOUT CENTRAL N°6 OS-V2 GAUCHE	2
210095	TOPO CENTRAL N°2 OS-V2 DIREITO CENT. N°2 RIGHT END-CAP / EMBOUT CENT. N°2 DROITE	2
210165	TOPO LATERAL SUP/INF N°15 OS-V2 LATERAL UPPER/LOWER N°15 OS-V2 END-CAP / EMBOUT LAT SUP/INF N°15 OS-V2	2
210194	TOPO LAT. INF. 20mm N°22 OS-V2 Sol. Inv. Fech. (OS 08) LAT. INF. 20mm N° 22 END-CAP EMBOUT LAT. INF. 20mm N° 22 ou or ou	2
210195	TOPO LAT. INF. 40mm N°23 OS-V2 Sol. Inv. Fech. (OS 18) LAT. INF. 40mm N° 23 END-CAP EMBOUT LAT. INF. 40mm N° 23	2
210159	TOPO ARO FIXO SOLEIRA OCULTA V2-N2 CONCEALED SILL FIXED FRAME END-CAP V2-N2 / EMBOUT CADRE DORMANT SEUIL CACHE V2-N2	4
212066	CONJUNTO TOPOS OS 61 KIT D'EMBOUT OS 61	** 2
213273	CORTA-VENTO OS SUPERIOR UPPER CENTRAL GASKET / PIÈCE D'ÉTANCHÉITE SUPÉRIEUR	1
213281	CORTA-VENTO SOL OCULTA OS 08 CONCEALED CENTRAL GASKET / PIÈCE D'ÉTANCHÉITE CACHÉE (OS 08)	1
213275	CORTA-VENTO SOL OCULTA OS 18 CONCEALED CENTRAL GASKET / PIÈCE D'ÉTANCHÉITE CACHÉE (OS 18)	1
210268	GOTEIRA C/ VÁLVULA SVE FLAP VALVE / CLAPET À VOLET	DIVERSOS DIVERSES / DIVERS
290020	PARAFUSO PAR 006 SCREW / VIS	DIVERSOS DIVERSES / DIVERS
215078	PEÇA ANTI-LEVANTAMENTO OS ANTI-LIFT ACCESSORY / ANTI-LEVAGE ACCESSOIRE	2
215083	ANTI-LEVANTAMENTO GUIA INOX OS OS GUIDE ANTI-LIFT ACCESSORY / ACCESSOIRE ANTI-LEVAGE POUR GUIDE	4
215194	CHAPA BLOQUEIO PELÚCIA PILE SEAL LOCK PLATE / PIÈCE MOLE DE VERROUILLAGE DE JOINT BROSSÉ	2
210510	TOPO BLOQUEIO PELÚCIA CV PILE SEAL LOCK END-CAP CV / EMBOUT DE VERROUILLAGE DE JOINT BROSSÉ CV	2
212246	CONJ. TOPOS CAL / SOL OS-D 2-RAIL DRAINAGE CHANNEL/SILL OS-D 2-RAIL END-CAP KIT / KIT D'EMBOUT DE GOUTTIÈRE/SEUIL OS-D 2-RAIL	1
210604	TAPA FURROS P/ AMORTECEDOR OS N.3 HOLE COVER FOR SHOCK ABSORBER N.3 / COUVERCLE DE TROU POUR AMORTISSEUR N.3	2

* Consultar lista de acessórios | Consult list of accessories | Consulter la liste des accessoires
** Opcional | Optional | Optionnel

VEDANTES SEALENTS JOINTS		
CODIGO CODE	DESIGNAÇÃO DESIGNATION / NOMINATION	QUANTIDADE QUANTITY / QUANTITÉ
208450	PELÚCIA 7x5.5 Cinza PILE SEAL / JOINT BROSSÉ	4L
ou or ou		
208465	PELÚCIA 7x5.5 Preta PILE SEAL / JOINT BROSSÉ	4L
208460	PELÚCIA 7x7 S-F PILE SEAL / JOINT BROSSÉ	6H
208458	PELÚCIA 7x7 Cinza PILE SEAL / JOINT BROSSÉ (OS 08 OS 18)	2L
ou or ou		
208467	PELÚCIA 7x7 Preta PILE SEAL / JOINT BROSSÉ (OS 08 OS 18)	2L
208468	PELÚCIA SRF 4x8 2P1M GRA Cinza PILE SEAL / JOINT BROSSÉ	4L
208499	VD 2063.N	2H
208193	VD 2060	2L
208193	JUNTA DE ESTANQUIDADE 2050 JOINT / JOINT	4H

JANELA DE CORRER 2 FOLHAS - COM 1 FECHADURA E 1 FECHO LATERAL - (vidros iguais)
2 SASHES SLIDING WINDOW - WITH 1 LOCK AND 1 LATERAL LOCK - (glasses with equal widths)
FENÊTRE COULISSANT 2 VANTAUX - AVEC 1 SERRURE ET 1 SERRURE LATÉRAL - (verres de même largeurs)

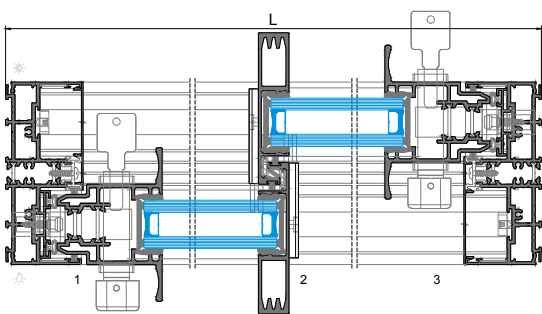
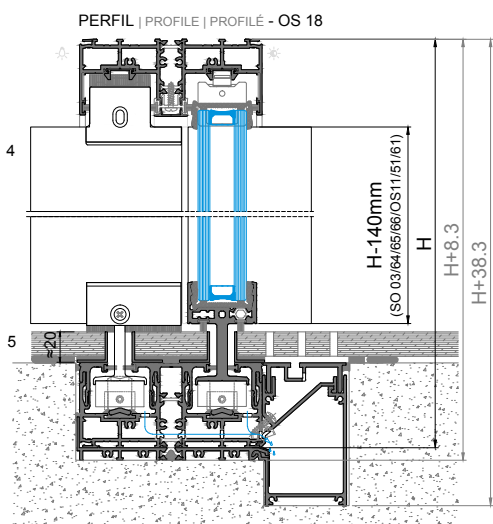
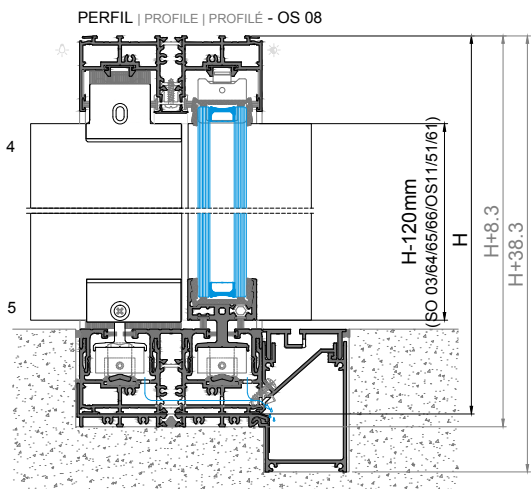
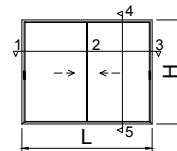

VEDANTES SEALENTS JOINTS		
CÓDIGO CODE	DESIGNAÇÃO DESIGNATION NOMINATION	QUANTIDADE QUANTITY QUANTITÉ
208450 ou ou ou	PELÚCIA 7x5.5 Cinza PILE SEAL JOINT BRASSE	4L
208465	PELÚCIA 7x5.5 Preta PILE SEAL JOINT BRASSE	
208460	PELÚCIA 7x7 S-F PILE SEAL JOINT BRASSE	6H
208456 ou ou ou	PELÚCIA 7x7 Cinza PILE SEAL JOINT BRASSE (OS 08 OS 18)	2L
208467	PELÚCIA 7x7 Preta PILE SEAL JOINT BRASSE (OS 08 OS 18)	
208468	PELÚCIA SRF 4x8 2P1M GRA Cinza PILE SEAL JOINT BRASSE	4L
208499	VD 2063.N	2H
208193	VD 2060	2L
208193	JUNTA DE ESTANQUIDADE 2050 JOINT JOINT	2H

PERFIS PROFILES PROFILÉS					
CÓDIGO CODE	DESIGNAÇÃO DESIGNATION NOMINATION	CORTE HORIZ. HORIZONTAL DETAIL	CORTE VERT. VERTICAL DETAIL	QUANT. QUANTITY	CORTE CUT COUPE
SO 11	ARO FIXO FIXED FRAME DORMANT	L	H	1+2	
SO 21	ARO FIXO SOLEIRA FIXED SILL FRAME SEUIL	L	-	1	
SO 03	ARO MÓVEL LATERAL/ FECHADURA LATERAL LOCK PROFILE JOUVRANT LAT. SERRURE	-	H-120 H-140	2	
SO 40	PERFIL TESTA FECHADURA	-	H-80 H-100	2	
SO 65	ARO MÓVEL LATERAL MOBILE FR. JOUVRANT	-	H-120 H-140	1	
OS 30	VARETA ROD PROFILE TIGE	-	VARIÁVEL VARIABLE VARIABLE	1	
OS 61	ARO MÓVEL CENTRAL PROFILE PROFILÉ	-	H-120 H-140	2	
OS 08 OS 18	ARO MÓVEL MOBILE FR. JOUVRANT	(L-136)/2 (L-169)/2	-	1	
OS 40	PERFIL REMATE PROFILE PROFILÉ	(L/2)-50,5	-	4	
OS 41	PERFIL REMATE PROFILE PROFILÉ	(L/2)/65,5	-	2	
OS 801	GUIA INF. INOX LOWER GUIDE GUIDE INFÉRIEUR	L-46	-	2	
OS 35	GUIA SUP. UPPER GUIDE GUIDE SUPÉRIEUR	L-46	-	2	
OS 95	POLIAMIDA POLYAMIDE POLYAMIDE	(L/2)-50	H-74	2+2	
OS 30	PERFIL REMATE PROFILE PROFILÉ	(L/2)-65	-	2	
SO 60	TAMPA DE CANAL TRACK COVER PROFILÉ CACHE CANAL	-	H-79	2	
SO 82	PERFIL SOLEIRA SILL PROFILE PROFILÉ DE SEUIL	CONSULTAR DEPARTAMENTO TÉCNICO CONSULT TECHNICAL DEPARTMENT CONSULTER DÉPARTEMENT TECHNIQUE			
SO 25	PERFIL CALEIRA DRAINAGE CHANNEL GOUTTIÈRE DE VIDANGE				
SO 59	TAMPA DE CALEIRA DRAINAGE CHANNEL GRID GRILLE POUR GOUTTIÈRE DE VIDANGE				
VO 11	PERFIL FIXAÇÃO TAMPA CHANNEL GRID FIX. PROF. PROF. FIXATION GRILLE				

(1) Peças com 400mm, aplicadas aproximadamente a cada 800mm | Pieces 400mm long, applied approximately every 800mm | Pièces de 400 mm, appliquées à environ tous les 800 mm

ACESSÓRIOS ACCESSORIES ACCESSOIRES		
CÓDIGO CODE	DESIGNAÇÃO DESIGNATION NOMINATION	QUANTIDADE QUANTITY QUANTITÉ
205162	CARRINHO OS N°5 ROLLER BEARING ROULEAU	4
205161	CARRINHO-GUIA OS SUPERIOR N°3 UPPER GUIDE ROLLER BEARING N3 ROULEAU-GUIDE SUPÉRIEUR N3	4
205172	ESQUADRO 18-2210-D BLOCKING BRACKET EQUEURRE	8
213018	CANTO ALINHAMENTO OS N.2 ANGLE ANGLE	4
	FECHADURA 3 PONTOS LOCK SERRURE	* 1
213220	AMORTECEDOR OS N.3 SHOCK ABSORBER AMORTISSEUR	4
280037	TESTA FECHADURA OS N.2 STRIKING PLATE GÂCHE	3
290105	PARAFUSO DIN7982 8x3/4 INOX A2 SCREW VIS	6
203306	COPO PARA TESTA FECHADURA RECESSED LOCK END-CAP EMBOUT À ENCASTRER POUR SERRURE	3
	CILINDRO CYLINDER CYLINDRE	* 1
220196	ESPELHO 23MM CYLINDER CYLINDRE	2
201089	FECHO LATERAL OS N°4 N.4 LATERAL LOCK SERRURE LATÉRALE N.4	1
228167	MOLA P/ RETENÇÃO FECHO OS N°2 OS LOCK RETAINER SPRING RESSORT DE RETENUE POUR FERMETURE OS	1
215037	PEÇA AJUSTE P/ FECHO LAT OS N.4 ADJUSTMENT PIECE	4
202323	CONTRA-FECHO OS INOX C/ AFINAÇÃO N°2 COUNTER-LOCK BRACKET CONTRE-FERMETURE SUPPORT	3
280000	TESTA OS-D P/ FECHO OS N.2 STRIKING PLATE GÂCHE	3
210125	TOPO CENTRAL N°6 OS-V2 SOL OCULTA ESQ CENTRAL END-CAP N°6 OS-V2 LEFT EMBOUT CENTRAL N°6 OS-V2 GAUCHE	2
210095	TOPO CENTRAL N°2 OS-V2 DIREITO CENT. N°2 RIGHT END-CAP EMBOUT CENT. N°2 DROITE	2
210165	TOPO LATERAL SUP/INF N°15 OS-V2 LATERAL UPPER/LOWER N°15 OS-V2 END-CAP EMBOUT LAT SUP/INF N°15 OS-V2	2
210166	TOPO LAT. INF. 20mm N°16 OS-V2 Sol. Invisível (OS 08) LAT. INF. 20mm N°16 END-CAP EMBOUT LAT. INF. 20mm N°16 ou ou ou	1
210167	TOPO LAT. INF. 40mm N°17 OS-V2 Sol. Invisível (OS 18) LAT. INF. 40mm N°17 END-CAP EMBOUT LAT. INF. 40mm N°17	
210194	TOPO LAT. INF. 20mm N°22 OS-V2 Sol. Inv. Fech. LAT. INF. 20mm N°22 END-CAP EMBOUT LAT. INF. 20mm N°22 ou ou ou	1
210195	TOPO LAT. INF. 40mm N°23 OS-V2 Sol. Inv. Fech. LAT. INF. 40mm N°23 END-CAP EMBOUT LAT. INF. 40mm N°23	
210159	TOPO ARO FIXO SOLEIRA OCULTA V2-N2 CONCEALED SILL FIXED FRAME END-CAP V2-N2 EMBOUT CADRE DORMANT SEUIL CACHE V2-N2	4
212066	CONJUNTO TOPOS OS 61 OS 61 END-CAP KIT KIT D'EMBOUT OS 61	** 2
213273	CORTA-VENTO OS SUPERIOR UPPER CENTRAL GASKET PIÈCE D'ÉTANCHÉITÉ SUPÉRIEUR	1
213281	CORTA-VENTO SOL OCULTA OS 08 CONCEALED CENTRAL GASKET PIÈCE D'ÉTANCHÉITÉ CACHÉE (OS 08) ou ou ou	1
213275	CORTA-VENTO SOL OCULTA OS 18 CONCEALED CENTRAL GASKET PIÈCE D'ÉTANCHÉITÉ CACHÉE (OS 18)	1
210268	GOTEIRA C/ VÁLVULA SVE FLAP VALVE CLAPET À VOLET	DIVERSOS DIVERS DIVERS
290020	PARAFUSO PAR 006 SCREW VIS	DIVERSOS DIVERS DIVERS
215078	PEÇA ANTI-LEVANTAMENTO OS ANTI-LIFT ACCESSORY ANTI-LEVAGE ACCESSOIRE	2
215083	ANTI-LEVANTAMENTO GUIA INOX OS OS GUIDE ANTI-LIFT ACCESSORY ACCESSOIRE ANTI-LEVAGE POUR GUIDE	4
215194	CHAPA BLOQUEIO PELÚCIA PILE SEAL LOCK PLATE PLAQUE DE VERROUILLAGE DE JOINT BRASSE	2
210510	TOPO BLOQUEIO PELÚCIA CV PILE SEAL LOCK END-CAP CV EMBOUT DE VERROUILLAGE DE JOINT BRASSE CV	2
212246	CONJ. TOPOS CAL/SOL OS-D 2-RAIL DRAINAGE CHANNEL/SILL OS-D 2-RAIL END-CAP KIT KIT D'EMBOUT OS DOUTRE SEUIL OS-D 2-RAIL	1
210604	TAPA FURROS P/ AMORTECEDOR OS N.3 HOLE COVER FOR SHOCK ABSORBER N.3 COUVERCLE DE TROU POUR AMORTISSEUR N.3	2

* Consultar lista de acessórios | Consult list of accessories | Consulter la liste des accessoires

** Opcional | Optional | Optionnel

JANELA DE CORRER 3 FOLHAS - COM 2 FECHADURAS - (vidros iguais)
3 SASHES SLIDING WINDOW - WITH 2 LOCKS - (glasses with equal widths)
FENÊTRE COULISSANT 3 VANTAOX - AVEC 2 SERRURES - (verres de même largeurs)

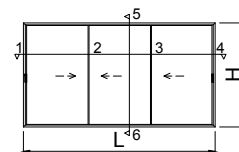

PERFIL | PROFILE | PROFILÉ - OS 08

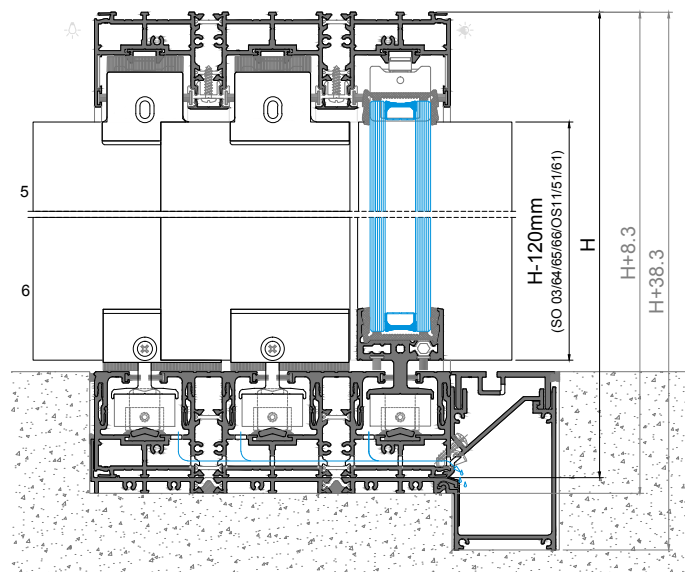

PERFIL | PROFILE | PROFILÉ - OS 08

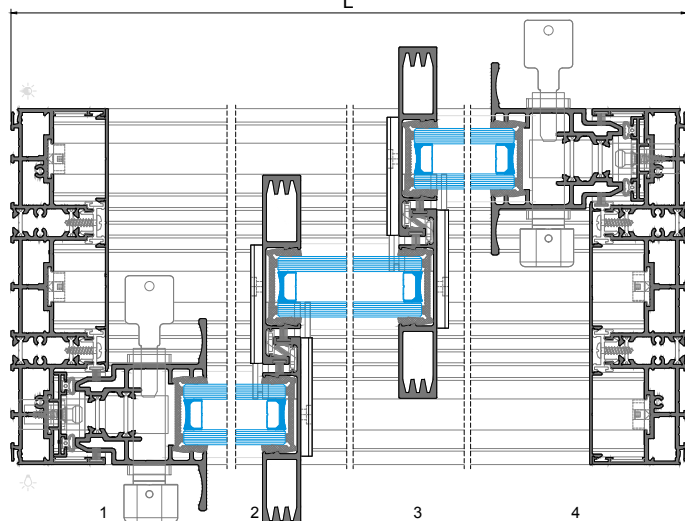
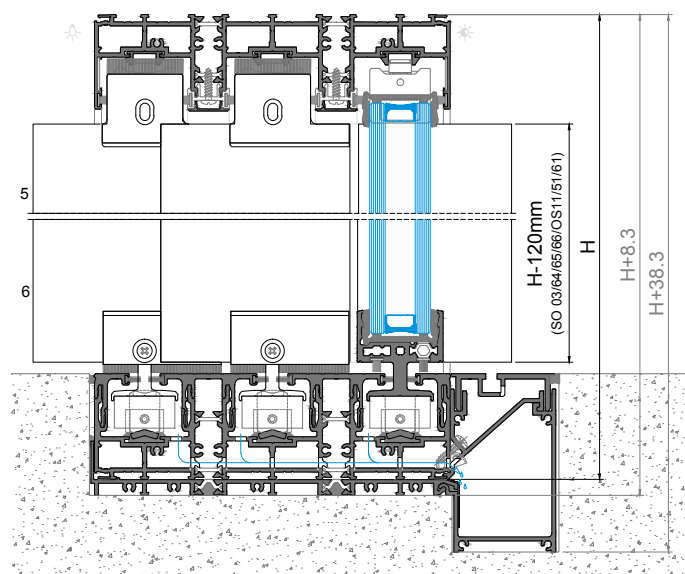

PERFIS | PROFILES | PROFILÉS

CÓDIGO CODE	DESIGNAÇÃO DESIGNATION NOMINATION	CORTE HORIZ. HORIZONTAL DETAIL		QUANT. QUANTITY	CORTE GUT. COUPE
		OS 08	OS 18		
SO 12	ARO FIXO FIXED FRAME DORMANT	L	H	1+2	
SO 22	ARO FIXO SOLEIRA FIXED SILL FRAME SEUIL	L	-	1	
SO 03	ARO MÓVEL LATERAL/ FECHADURA LATERAL LOCK PROFILE JOINTANT LAT. SERRURE	-	H-120	H-140	2
SO 40	PERFIL TESTA FECHADURA LOCK PLATE PROFILE PROFILÉ POUR SERRURE	-	H-80	H-100	2
OS 61	ARO MÓVEL CENTRAL PROFILE PROFILÉ	-	H-120	H-140	4
OS 08	ARO MÓVEL MOBILE FR. OUVRANT	(L-143)/3 (L-196)/3	-	-	1
OS 18	ARO MÓVEL MOBILE FR. OUVRANT	(L3)-26.5	-	-	2
OS 40	PERFIL REMATE PROFILE PROFILÉ	(L3)-36.5x2	-	-	2
OS 41	PERFIL REMATE PROFILE PROFILÉ	(2L-265)/3 (L-125)/3	-	-	2
OS 801	GUIA INF. INOX LOWER GUIDE GUIDE INFÉRIEUR	L-46	-	-	3
OS 35	GUIA SUP. UPPER GUIDE GUIDE SUPÉRIEUR	L-46	-	-	3
OS 95	POLIAMIDA POLYAMIDE POLYAMIDE	(2L-217)/3 (L-77)/3	H-74	-	2 + 4
OS 30	PERFIL REMATE PROFILE PROFILÉ	(L3)-44x2 L/3-42	-	-	2
OS 61	TAMPA DE CANAL TRACK COVER PROFILE CACHE CANAL	-	H-79	-	2
SO 84	PERFIL SOLEIRA SILL PROFILE PROFILÉ DE SEUIL	CONSULTAR DEPARTAMENTO TÉCNICO CONSULT TECHNICAL DEPARTMENT CONSULTER DÉPARTEMENT TECHNIQUE			
SO 25	PERFIL CALEIRA DRAINAGE CHANNEL GOÛTIERE DE VIDANGE				
SO 69	TAMPA DE CALEIRA DRAINAGE CHANNEL GRID GRILLE POUR GOÛTIERE DE VIDANGE				
VO 11	PERFIL FIXAÇÃO TAMPA DRAINAGE CHANNEL GRID FIX. PROF. PROF. FIXATION GRILLE				

(1) Peças com 400mm, aplicadas aproximadamente a cada 800mm | Pieces 400mm long, applied approximately every 800mm | Pièces de 400 mm, appliquées à environ tous les 800 mm

ACESSÓRIOS | ACCESSORIES | ACCESSOIRES

CÓDIGO CODE	DESIGNAÇÃO DESIGNATION NOMINATION	QUANTIDADE QUANTITY QUANTITÉ
205162	CARRINHO OS Nº5 ROLLER BEARING ROULEAU	6
205161	CARRINHO-GUIA OS SUPERIOR Nº3 UPPER-GUIDE ROLLER BEARING N3 ROULEAU-GUIDE SUPÉRIEUR N3	6
205172	ESQUADRO 18-2210-D BLOCKING BRACKET ÉQUERRE	16
213018	CANTO ALINHAMENTO OS N.2 ANGLE ANGLE	4
	FECHADURA 3 PONTOS LOCK SERRURE	*
213220	AMORTECEDOR OS N.3 SHOCK ABSORBER AMORTISSEUR	4
280037	TESTA FECHADURA OS N.2 STRIKING PLATE GÂCHE	6
290105	PARAFUSO DIN7982 8x3/4 INOX A2 SCREW VIS	12
203306	COPO PARA TESTA FECHADURA RECESSED LOCK END-CAP EMBOUT À ENCASTRER POUR SERRURE	6
	CILINDRO CYLINDER CYLINDRE	*
220196	ESPELHO 23MM CYLINDER CYLINDRE	4
210125	TOPO CENTRAL Nº6 OS-V2 SOL OCULTA ESQ CENTRAL END-CAP Nº6 OS-V2 LEFT EMBOUT CENTRAL Nº8 OS-V2 GAUCHE	2
210095	TOPO CENTRAL Nº2 OS-V2 DIREITO CENT. Nº2 RIGHT END-CAP EMBOUT CENT. Nº2 DROITE	2
210165	TOPO LATERAL SUP/INF Nº15 OS-V2 LATERAL UPPER/LOWER Nº15 OS-V2 END-CAP EMBOUT LAT SUP/INF Nº15 OS-V2	2
210194	TOPO LAT. INF. 20mm Nº22 OS-V2 Sol. Inv. Fech. (OS 08) LAT. INF. 20mm Nº 22 END-CAP EMBOUT LAT. INF. 20mm Nº 22 ou or ou	2
210195	TOPO LAT. INF. 40mm Nº23 OS-V2 Sol. Inv. Fech. (OS 18) LAT. INF. 40mm Nº 23 END-CAP EMBOUT LAT. INF. 40mm Nº 23	2
210159	TOPO ARO FIXO SOLEIRA OCULTA V2-N2 CONCEALED SILL FIXED FRAME END-CAP Nº2 EMBOUT CADRE DORMANT SEUIL CACHE V2-N2	6
212066	CONJUNTO TOPOS OS 61 OS 61 END-CAP KIT KIT D'EMBOUT OS 61	**
213273	CORTA-VENTO OS SUPERIOR UPPER CENTRAL GASKET PIÈCE D'ÉTANCHÉITE SUPÉRIEUR	2
213281	CORTA-VENTO SOL OCULTA OS 08 CONCEALED CENTRAL GASKET PIÈCE D'ÉTANCHÉITE CACHÉE (OS 08) ou or ou	2
213275	CORTA-VENTO SOL OCULTA OS 18 CONCEALED CENTRAL GASKET PIÈCE D'ÉTANCHÉITE CACHÉE (OS 18)	2
210288	GOTEIRA C/ VÁLVULA SVE FLAP VALVE CLAPET À VOLET	DIVERSOS DIVERSES DIVERS
290020	PARAFUSO PAR 006 SCREW VIS	DIVERSOS DIVERSES DIVERS
215078	PEÇA ANTI-LEVANTAMENTO OS ANTI-LIFT ACCESSORY ANTI-LEVAGE ACCESSOIRE	2
215083	ANTI-LEVANTAMENTO GUIA INOX OS OS GUIDE ANTI-LIFT ACCESSORY ACCESSOIRE ANTI-LEVAGE POUR GUIDE	6
215194	CHAPA BLOQUEIO PELÚCIA PILE SEAL LOCK VERROUILLAGE DE JOINT BROSSÉ	4
210510	TOPO BLOQUEIO PELÚCIA CV PILE SEAL LOCK END-CAP EMBOUT DE VERROUILLAGE DE JOINT BROSSÉ CV	4
212247	CONJ. TOPOS CAL/SOL OS-D 3-RAIL DRAINAGE CHANNEL/SILL OS-D 3-RAIL END-CAP KIT KIT D'EMBOUT DE GOÛTIERE/SILL OS-D 3-RAIL	1
210604	TAPA FUROS P/ AMORTECEDOR OS N.3 HOLE COVER FOR SHOCK ABSORBER N.3 COUVERCLE DE TROU POUR AMORTISSEUR N.3	2

* Consultar lista de acessórios | Consult list of accessories | Consulter la liste des accessoires
** Opcional | Optional | Optionnel

VEDANTES | SEALENTS | JOINTS

CÓDIGO CODE	DESIGNAÇÃO DESIGNATION NOMINATION	QUANTIDADE QUANTITY QUANTITÉ
208450	PELÚCIA 7x5.5 Cinza PILE SEAL JOINT BROSSÉ ou or ou	6L
208465	PELÚCIA 7x5.5 Preta PILE SEAL JOINT BROSSÉ	6L
208460	PELÚCIA 7x7 S-F PILE SEAL JOINT BROSSÉ	8H
208458	PELÚCIA 7x7 Cinza PILE SEAL JOINT BROSSÉ (OS 08 OS 18) ou or ou	2L
208467	PELÚCIA 7x7 Preta PILE SEAL JOINT BROSSÉ (OS 08 OS 18)	2L
208468	PELÚCIA SRF 4x8 2P1M GRA Cinza PILE SEAL JOINT BROSSÉ	6L
208499	VD 2063.N	4H
208193	VD 2060	3L
208193	JUNTA DE ESTANQUIDADE 2050 JOINT JOINT	4H

JANELA DE CORRER 3 FOLHAS - COM 1 FECHADURA E 1 FECHO LATERAL - (vidros iguais)
3 SASHES SLIDING WINDOW - WITH 1 LOCK AND 1 LATERAL LOCK - (glasses with equal widths)
FENÊTRE COULISSANT 3 VANTAUX - AVEC 1 SERRURE ET 1 SERRURE LATÉRAL - (verres de même largeurs)

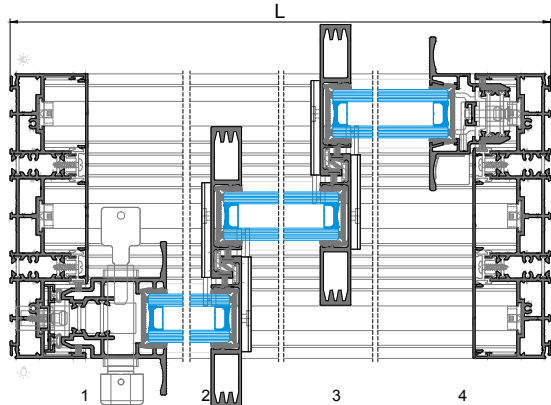
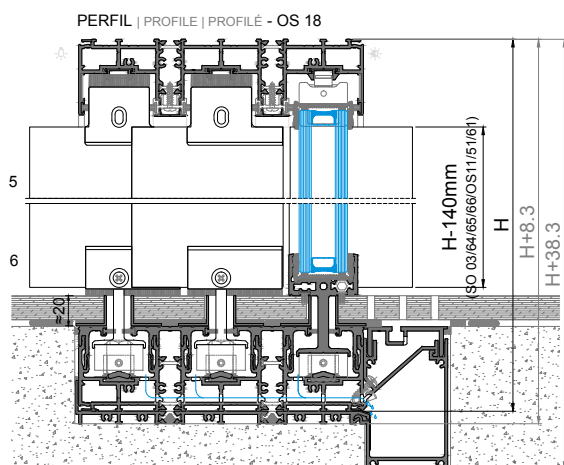
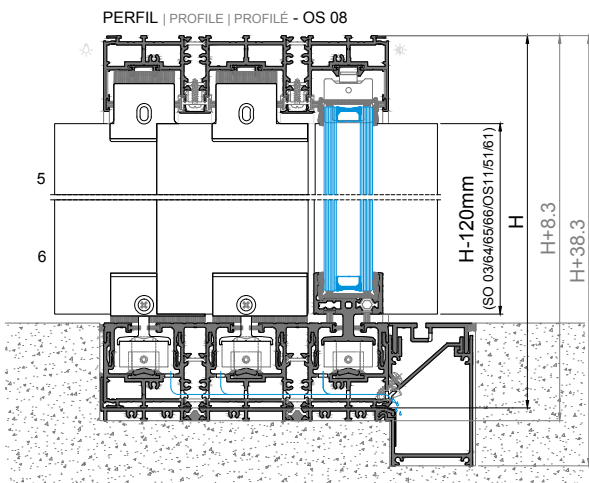
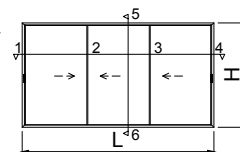

VEDANTES SEALENTS JOINTS		
CÓDIGO CODE	DESIGNAÇÃO DESIGNATION / NOMINATION	QUANTIDADE QUANTITY / QUANTITE
208450 ou or ou	PELÚCIA 7x5.5 Cinza PILE SEAL JOINT BRASSE	4L
208465 ou or ou	PELÚCIA 7x5.5 Preta PILE SEAL JOINT BRASSE	4L
208460	PELÚCIA 7x7 S-F PILE SEAL JOINT BRASSE	6H
208458 ou or ou	PELÚCIA 7x7 Cinza PILE SEAL JOINT BRASSE (OS 08 OS 18)	2L
208467 ou or ou	PELÚCIA 7x7 Preta PILE SEAL JOINT BRASSE (OS 08 OS 18)	2L
208468	PELÚCIA SRF 4x8 2P1M GRA Cinza PILE SEAL JOINT BRASSE	4L
208499	VD 2063.N	2H
208193	VD 2060	2L
208193	JUNTA DE ESTANQUIDADE 2050 JOINT JOINT	2H

PERFIS PROFILES PROFILÉS					
CÓDIGO CODE	DESIGNAÇÃO DESIGNATION / NOMINATION	CORTE HORIZ. HORIZONTAL DETAIL	CORTE VERT. VERTICAL DETAIL	QUANT. QUANTITY	CORTE CUT / COUPE
SO 12	ARO FIXO FIXED FRAME DORMANT	L	H	1+2	
SO 22	ARO FIXO SOLEIRA FIXED SILL FRAME SEUIL	L	-	1	
SO 03	ARO MÓVEL LATERAL/ FECHADURA LATERAL LOCK PROFILE PROFILÉ À SERRURE	-	H-120	H-140	2
SO 40	PERFIL TESTA FECHADURA LOCK PLATE PROFILE PROFILÉ POUR SERRURE	-	H-80	H-100	2
SO 65	ARO MÓVEL LATERAL MOBILE FR. OUVRANT	-	H-120	H-140	1
SO 30	VARETA ROD PROFILE TIGE	-	VARIÁVEL VARIABLE VARIABLE	1	
OS 61	ARO MÓVEL CENTRAL PROFILE PROFILÉ	-	H-120	H-140	4
OS 08 OS 18	ARO MÓVEL MOBILE FR. OUVRANT	(L-121)/3 (L-120)/3 (L-172)/3	-	1 1 1	
OS 40	PERFIL REMATE PROFILE PROFILÉ	(L3)-26.5 (L3)-38.5)x2	-	2 2	
OS 41	PERFIL REMATE PROFILE PROFILÉ	(L2)-26.5) (L-125)/3	-	2 2	
OS 801	GUIA INF. INOX LOWER GUIDE GUIDE INFÉRIEUR	L-46	-	3	
OS 35	GUIA SUP. UPPER GUIDE GUIDE SUPÉRIEUR	L-46	-	3	
OS 95	POLIAMIDA POLYAMIDE POLYAMIDE	(L2-217)/3 (L-77)/3	H-74	2 + 4	
OS 30	PERFIL REMATE PROFILE PROFILÉ	(L3)-44)x2 L3-42	-	2 2	
SO 61	TAMPA DE CANAL TRACK COVER PROFILE CACHE CANAL	-	H-79	2	
SO 84	PERFIL SOLEIRA SILL PROFILE PROFILÉ DE SEUIL	CONSULTAR DEPARTAMENTO TÉCNICO CONSULT TECHNICAL DEPARTMENT CONSULTER DÉPARTEMENT TECHNIQUE			
SO 25	PERFIL CALEIRA DRAINAGE CHANNEL GOÛTTIÈRE DE VIDANGE				
SO 59	TAMPA DE CALEIRA DRAINAGE CHANNEL GRID GRILLE POUR GOÛTTIÈRE DE VIDANGE				
VO 11	PERFIL FIXAÇÃO TAMPA DRAINAGE (1) CHANNEL GRID FIX. PROF. PROF. FIXATION GRILLE				

(1) Peças com 400mm, aplicadas aproximadamente a cada 800mm | Pieces 400mm long, applied approximately every 800mm | Pièces de 400 mm, appliquées à environ tous les 800 mm

ACESSÓRIOS ACCESSORIES ACCESSOIRES		
CÓDIGO CODE	DESIGNAÇÃO DESIGNATION / NOMINATION	QUANTIDADE QUANTITY / QUANTITE
205162	CARRINHO OS N°5 ROLLER BEARING ROULEAU	6
205161	CARRINHO-GUIA OS SUPERIOR N°3 UPPER-GUIDE ROLLER BEARING N3 ROULEAU-GUIDE SUPÉRIEUR N3	6
205172	ESQUADRO 18-2210-D BLOCKING BRACKET ÉQUERRE	16
213018	CANTO ALINHAMENTO OS N.2 ANGLE ANGLE	4
	FECHADURA 3 PONTOS LOCK SERRURE	1
213220	AMORTECEDOR OS N.3 SHOCK ABSORBER AMORTISSEUR	4
280037	TESTA FECHADURA OS N.2 STRIKING PLATE GÂCHE	3
290105	PARAFUSO DIN7982 8x3/4 INOX A2 SCREW VIS	6
203306	COPO PARA TESTA FECHADURA RECESSED LOCK END-CAP EMBOUT À ENCASTER POUR SERRURE	3
	CILINDRO CYLINDER CYLINDRE	1
220196	ESPELHO 23MM CYLINDER CYLINDRE	2
201089	FECHO LATERAL OS N°4 N°4 LATERAL LOCK SERRURE LATÉRALE N°4	1
228167	MOLA P/ RETENÇÃO FECHO OS N°2 OS LOCK RETAINER SPRING RESORT DE RETENUE POUR FERMETURE OS	1
215037	PEÇA AJUSTE P/FECHO LAT OS N.4 ADJUSTMENT PIECE PIÈCE DE REGLAGE	4
202323	CONTRA-FECHO OS INOX C/ AFINAÇÃO N°2 COUNTER-LOCK BRACKET CONTRE-FERMETURE SUPPORT	3
280000	TESTA OS-D P/FECHO OS N.2 STRIKING PLATE GÂCHE	3
210125	TOPO CENTRAL N°6 OS-V2 SOL OCULTA ESQ CENTRAL END-CAP N°6 OS-V2 LEFT EMBOUT CENTRAL N°6 OS-V2 GAUCHE	4
210095	TOPO CENTRAL N°2 OS-V2 DIREITO CENT. N°2 RIGHT END-CAP EMBOUT CENT. N°2 DROITE	4
210165	TOPO LATERAL SUP/INF N°15 OS-V2 LATERAL UPPER/LOWER N°15 OS-V2 END-CAP EMBOUT LAT SUP/INF N°15 OS-V2	2
210166	TOPO LAT. INF. 20mm N°16 OS-V2 Sol. Invisível LAT. INF. 20mm N°16 END-CAP EMBOUT LAT. INF. 20mm N°16 (OS 08) ou or ou	1
210167	TOPO LAT. INF. 40mm N°17 OS-V2 Sol. Invisível LAT. INF. 40mm N°17 END-CAP EMBOUT LAT. INF. 40mm N°17 (OS 18)	1
210194	TOPO LAT. INF. 20mm N°22 OS-V2 Sol. Inv. Fech. LAT. INF. 20mm N°22 END-CAP EMBOUT LAT. INF. 20mm N°22 (OS 08) ou or ou	1
210195	TOPO LAT. INF. 40mm N°23 OS-V2 Sol. Inv. Fech. LAT. INF. 40mm N°23 END-CAP EMBOUT LAT. INF. 40mm N°23 (OS 18)	1
210159	TOPO ARO FIXO SOLEIRA OCULTA V2-N2 CONCEALED SILL FIXED FRAME END-CAP V2-N2 EMBOUT CADRE DORMANT SEUIL CACHE V2-N2	6
212066	CONJUNTO TOPOS OS 61 OS 61 END-CAP KIT KIT D'EMBOUT OS 61	4
213273	CORTA-VENTO OS SUPERIOR UPPER CENTRAL GASKET PIÈCE DE D'ÉTANCHÉITE SUPÉRIEUR	2
213281	CORTA-VENTO SOL OCULTA OS 08 CONCEALED CENTRAL GASKET PIÈCE D'ÉTANCHÉITE CACHÉE (OS 08) ou or ou	2
213275	CORTA-VENTO SOL OCULTA OS 18 CONCEALED CENTRAL GASKET PIÈCE D'ÉTANCHÉITE CACHÉE (OS 18)	2
210268	GOTEIRA C/ VÁLVULA SVE FLAP VALVE CLAPET À VOILET	DIVERSOS DIVERSES DIVERS
290020	PARAFUSO PAR 006 SCREW VIS	DIVERSOS DIVERSES DIVERS
215078	PEÇA ANTI-LEVANTAMENTO OS ANTI-ACCESSORY ANTI-LEVAGE ACCESSOIRE	2
215063	ANTI-LEVANTAMENTO GUIA INOX OS OS GUIDE ANTI-LIFT ACCESSORY ACCESSOIRE ANTI-LEVAGE POUR GUIDE	6
215194	CHAPA BLOQUEIO PELÚCIA PILE SEAL LOCK PLATE PLAQUE DE VERROUILLAGE DE JOINT BRASSE	4
210510	TOPO BLOQUEIO PELÚCIA CV PILE SEAL LOCK END-CAP CV EMBOUT DE VERROUILLAGE DE JOINT BRASSE CV	4
212247	CONJ. TOPOS CAL/SOL OS-D 3-RAIL DRAINAGE CHANNEL/SILL OS-D 3-RAIL END-CAP KIT KIT D'EMBOUT DE GOÛTTIÈRE/SEUIL OS-D 3-RAIL	1
210604	TAPA FUROS P/ AMORTECEDOR OS N.3 HOLE COVER FOR SHOCK ABSORBER N.3 COUVERCLE DE TROU POUR AMORTISSEUR N.3	2

* Consultar lista de acessórios | Consult list of accessories | Consulter la liste des accessoires
** Opcional | Optional | Optionnel

JANELA DE CORRER 2 FOLHAS COM APLICAÇÃO DE REDE MOSQUITEIRA PELO EXTERIOR - Perfis OS 08 e OS 18
2 SASHES SLIDING WINDOW WITH OUTER MOSQUITO NET - Profiles OS 08 and OS 18
FENÊTRE COULISSANT 2 VANTAUX AVEC MOUSTIQUAIRE VERS L'EXTÉRIEUR - Profilés OS 08 et OS 18

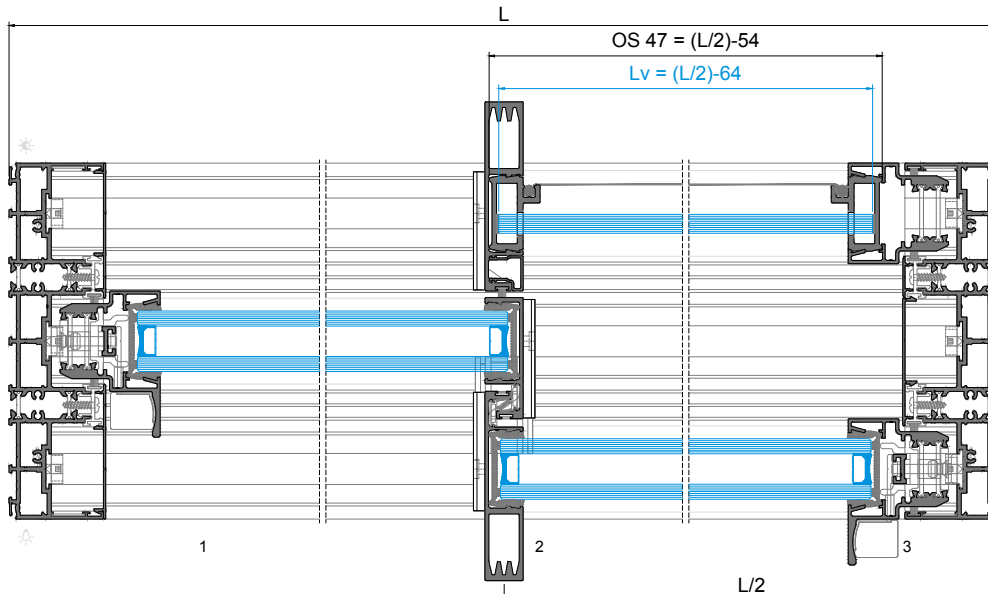
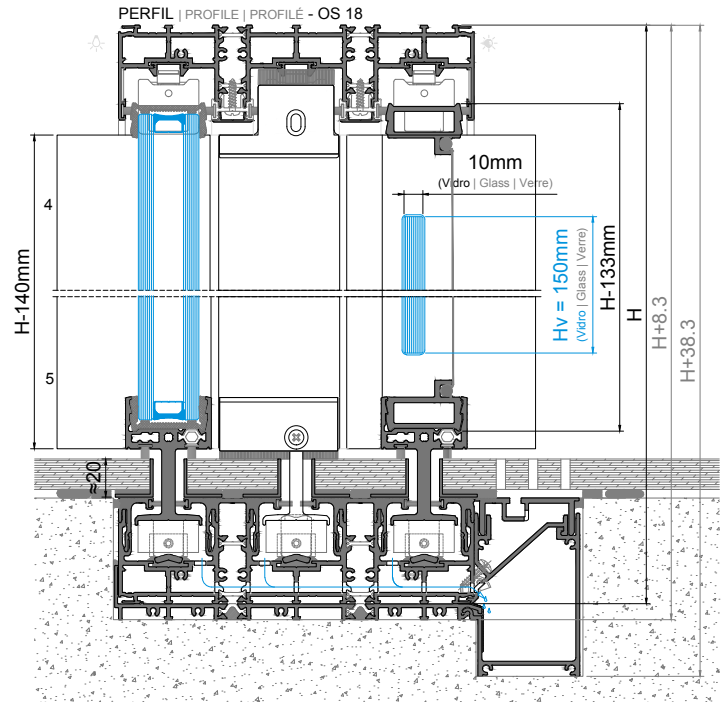
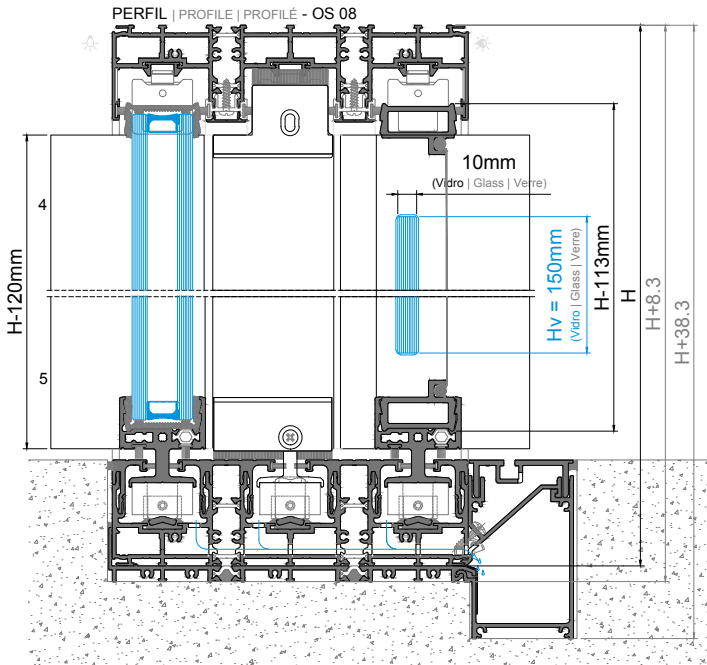
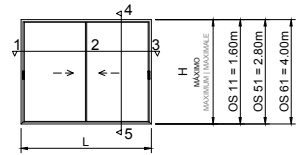



Clube de Vela da Costa Nova | Aveiro | Ferreira Arquitectos | Fotografia Ivo Tavares Studio

VI

MAQUINAÇÕES, CORTES E FRESAGENS MACHININGS, CUTS AND MILLINGS USINAGES, COUPES ET FRAISAGES

Maquinações e fresagens em aros fixos Fixed frames machinings and millings Usinages et fraisages en dormants	VI . 1
Maquinações e fresagens em aros fixos Mobile frames machinings and millings Usinages et fraisages en ouvrants	VI . 2
Maquinações e fresagens para acessórios Accessories machinings and millings Usinages et fraisages pour accessoires	VI . 3
Fixação dos caixilhos em obra Frames fixing Fixation des châssis	VI . 4

CORTANTE ESQUADROS OS Nº2
N.2 OS CORNER CLEATS PUNCHING TOOL
POINÇON EQUÉRRES OS N.2

OPERAÇÕES PARA ESQUADROS
CORNER CLEATS OPERATIONS
OPÉRATIONS POUR L'EQUÉRRES

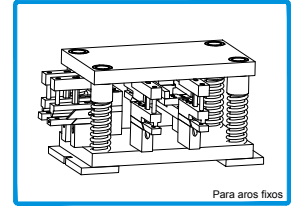

Para aros fixos
408175 CORTANTE ESQUADROS
OS Nº 2

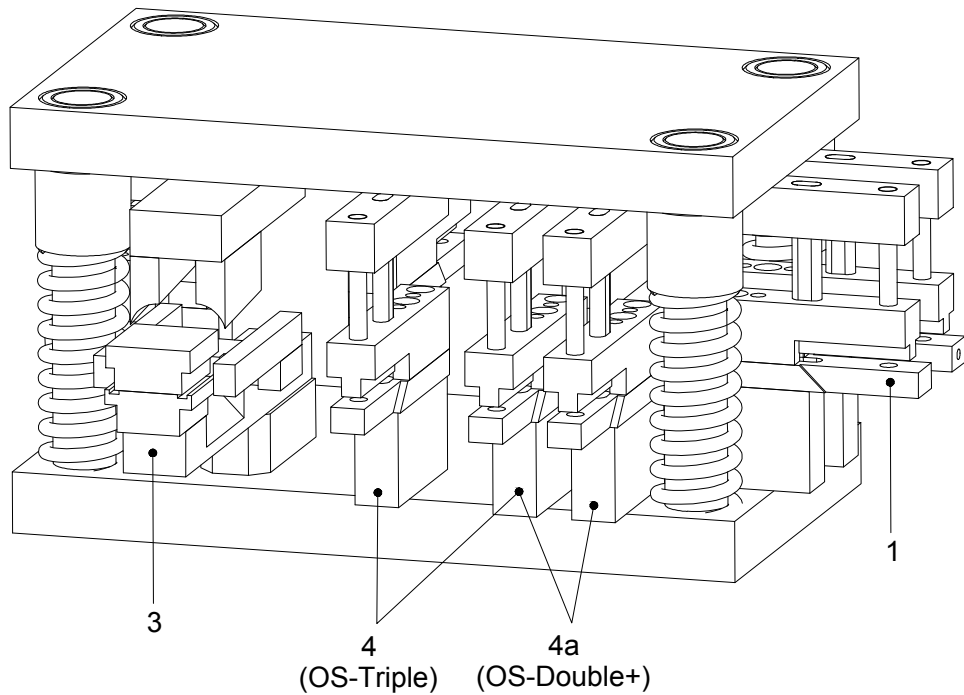
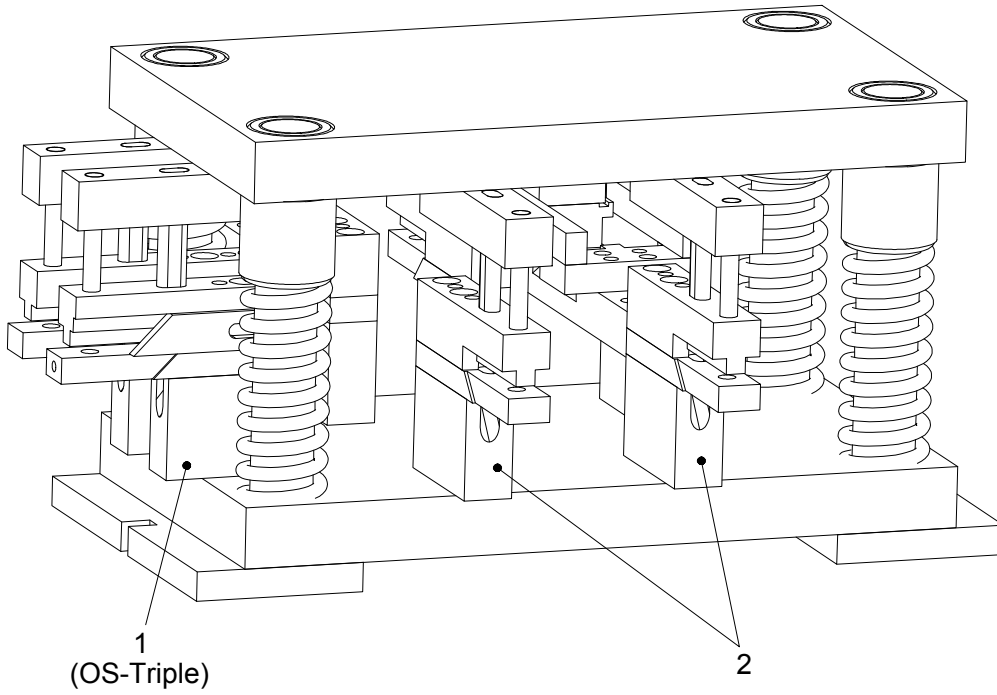

CORTANTE ESQUADROS OS Nº2
N.2 OS CORNER CLEATS PUNCHING TOOL
POINÇON EQUÉRRES OS N.2

OPERAÇÃO 1 | CUT 1 | USINAGE 1

MAQUINAÇÃO PARA ESQUADRO OS-TRIPLE - *Operação não utilizada na OS-Double⁺*
OS-TRIPLE CORNER CLEATS MACHINING - *Unused operation in OS-Double⁺*
USINAGE POUR EQUÉRRE OS-TRIPLE - *Opération non utilisée dans OS-Double⁺*

OPERAÇÃO 2 | CUT 2 | USINAGE 2

MAQUINAÇÃO PARA ESQUADRO OS-DOUBLE
OS-DOUBLE CORNER CLEATS MACHINING | USINAGE POUR EQUÉRRE OS-DOUBLE

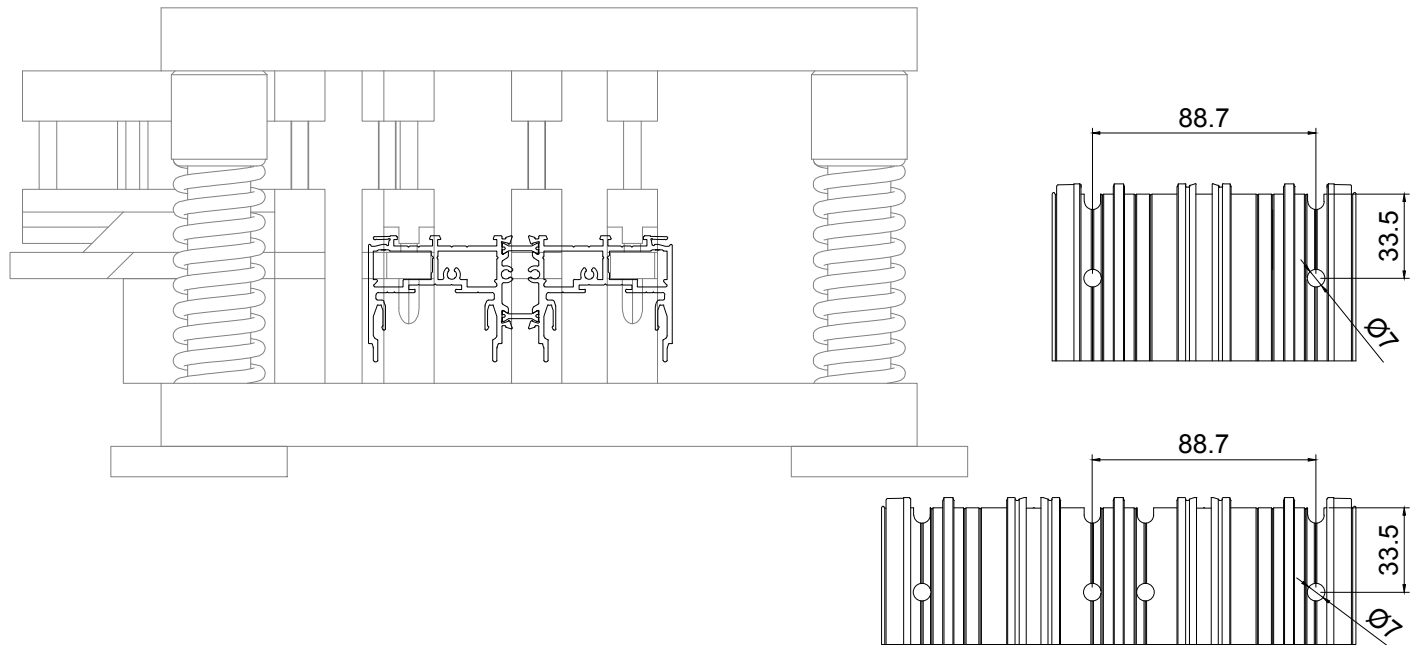

1º GOLPE | 1ST PUNCH | 1^{ERE} COUP

2º GOLPE | 2ND PUNCH | 2^{EME} COUP

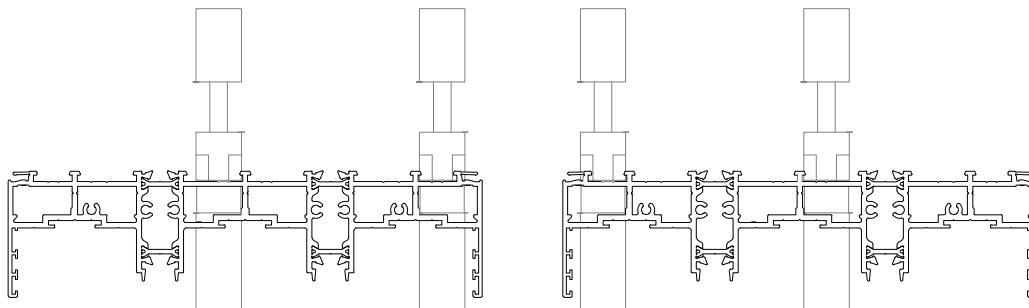

OPERAÇÃO 3 | CUT 3 | USINAGE 3

MAQUINAÇÃO PARA CORTE CLIP
CLIP CUT MACHINING | USINAGE POUR COUP CLIP

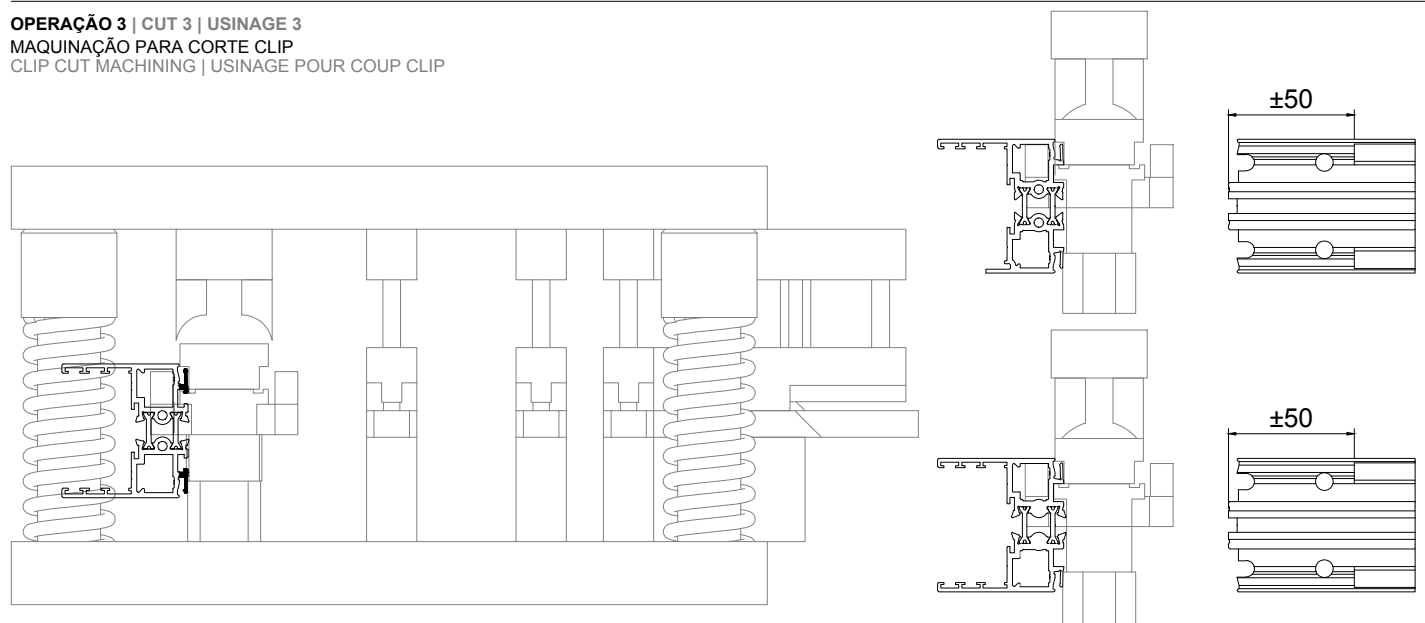

CORTANTE ESQUADROS OS Nº2
N.2 OS CORNER CLEATS PUNCHING TOOL
POINÇON EQUÉRRES OS N.2

OPERAÇÃO 4 | CUT 4 | USINAGE 4

MAQUINAÇÃO PARA ESQUADRO OS-TRIPLE - *Operação não utilizada na OS-Double⁺*
OS-TRIPLE CORNER CLEATS MACHINING - *Unused operation in OS-Double⁺*
USINAGE POUR EQUÉRRE OS-TRIPLE - *Opération non utilisée dans OS-Double⁺*

OPERAÇÃO 4a | CUT 4a | USINAGE 4a

MAQUINAÇÃO PARA ESQUADRO OS 1RAIL
OS 1RAIL CORNER CLEATS MACHINING | USINAGE POUR EQUÉRRE OS 1RAIL

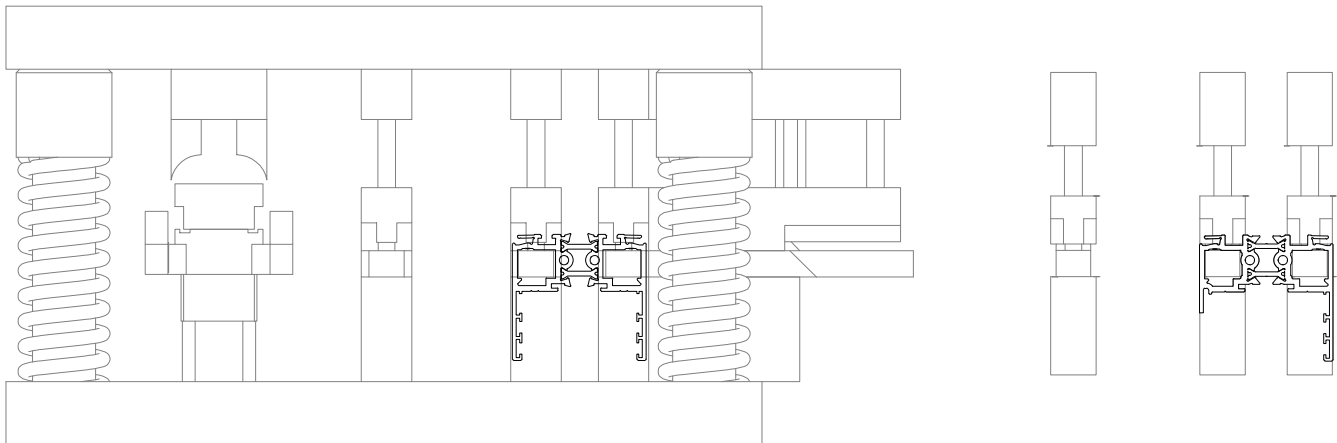
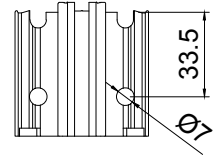

OPERAÇÃO 5 | CUT 5 | USINAGE 5

MAQUINAÇÃO PARA ESQUADRO - MOSQUITEIRA
CORNER CLEAT MACHINING - MOSQUITO NET | USINAGE POUR EQUÉRRE - MOUSTIQUEIRE

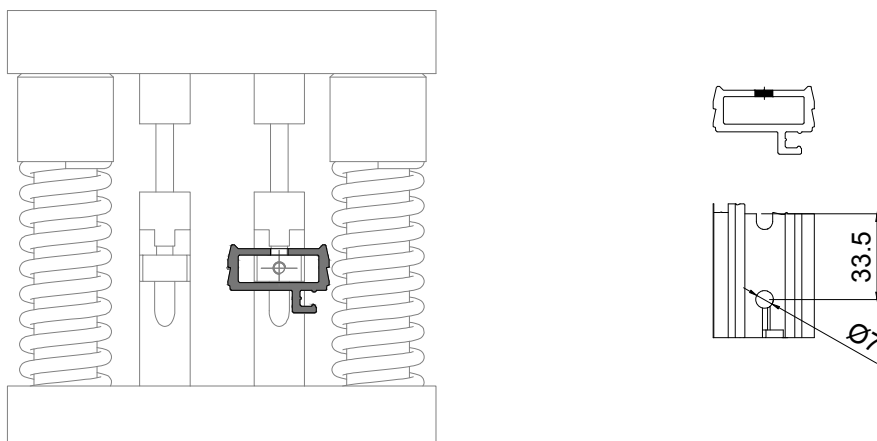

CORTANTE CAPAS OS-D
OS-D COVERS PUNCHING TOOL
POINÇON CAPOTS OS-D

OPERAÇÕES PARA CAPAS
COVERS OPERATIONS
OPÉRATIONS POUR CAPOTS

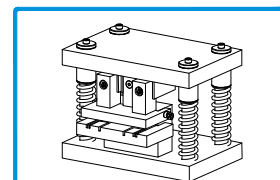

Para os perfis SO 60, SO 61, SO 62 e SO 63

408024 CORTANTE CAPAS OS-D

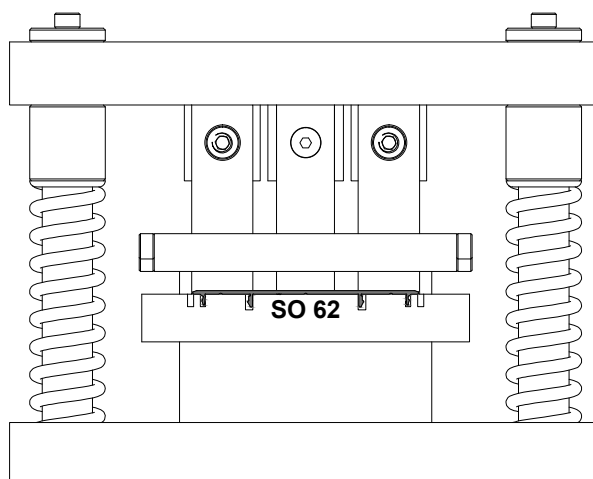
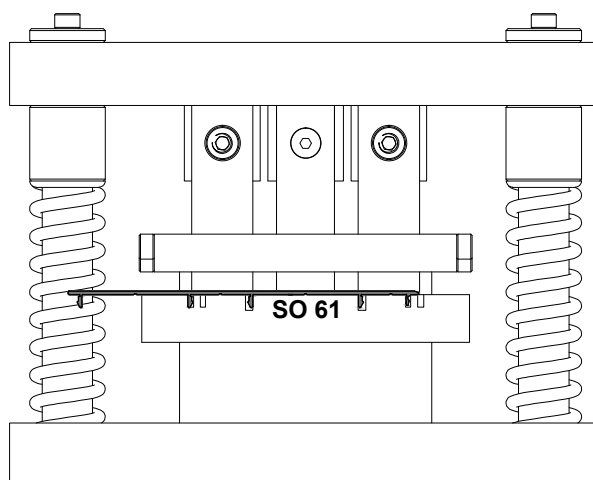
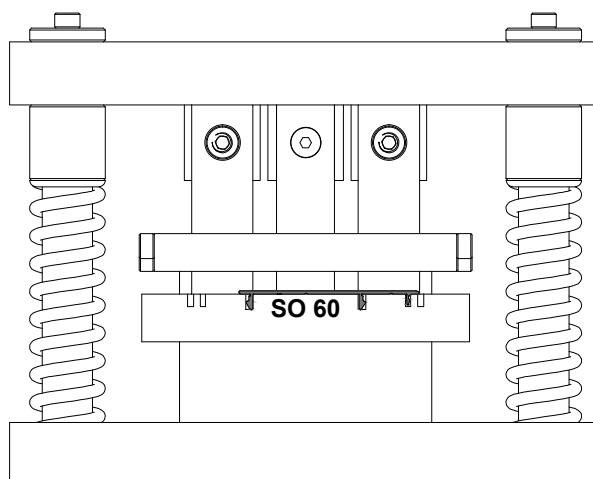

MAQUINAÇÃO E FRESAGEM DO PERFIL SO 60 - SOLEIRA TRADICIONAL
SO 60 PROFILE MACHINING AND MILLING - CLASSIC SILL
USINAGE ET FRAISAGE DU PROFILÉ SO 60 - SEUIL CLASSIQUE

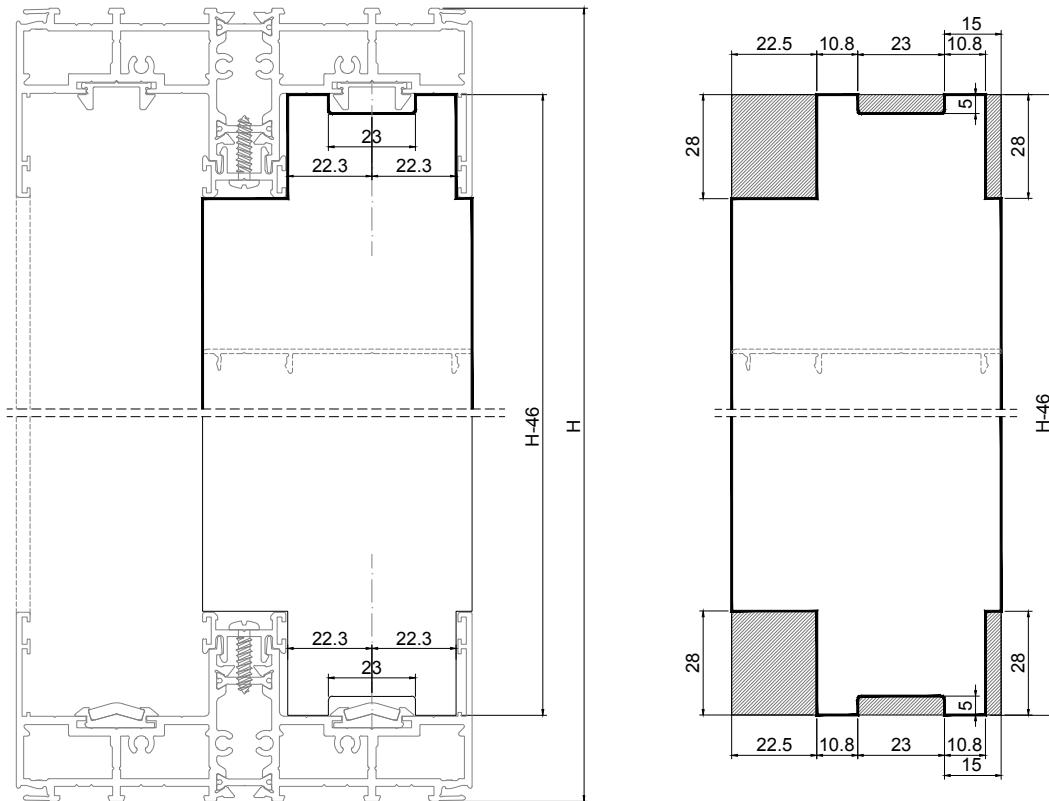

MAQUINAÇÃO E FRESAGEM DO PERFIL SO 60 - SOLEIRA OCULTA
SO 60 PROFILE MACHINING AND MILLING - CONCEALED SILL
USINAGE ET FRAISAGE DU PROFILÉ SO 60 - SEUIL CACHÉ

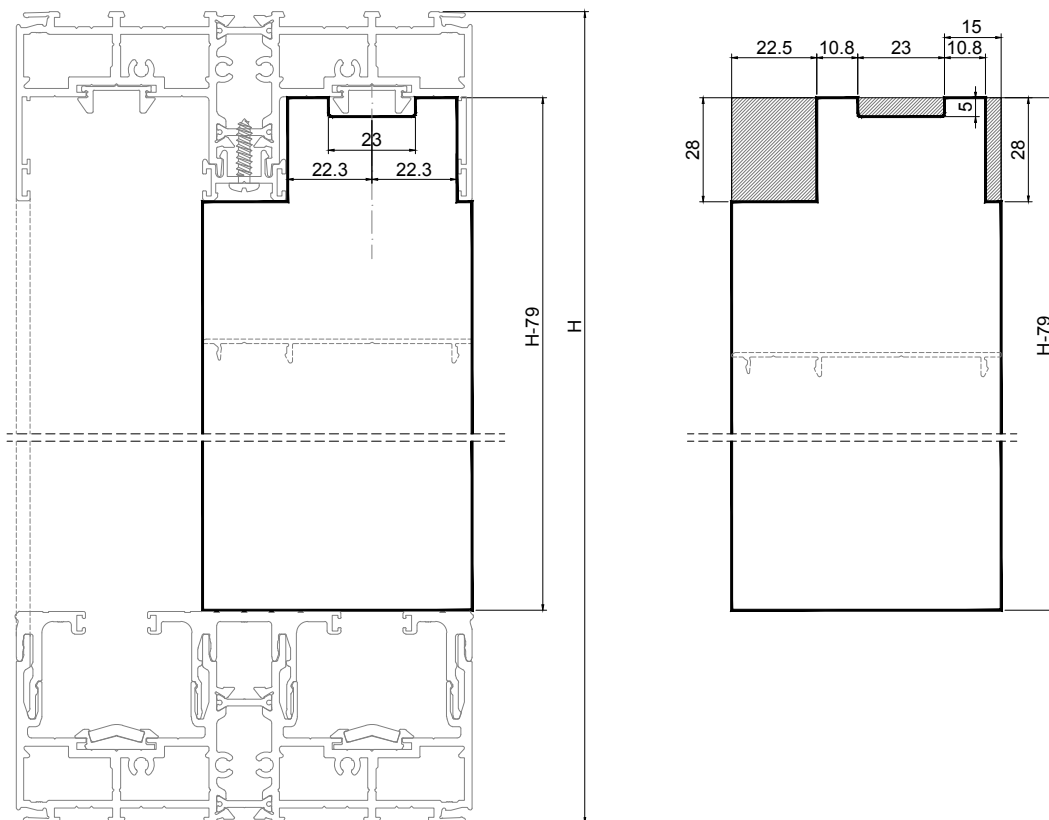

MAQUINAÇÃO E FRESAGEM DO PERFIL SO 61 - SOLEIRA TRADICIONAL
SO 61 PROFILE MACHINING AND MILLING - CLASSIC SILL
USINAGE ET FRAISAGE DU PROFILÉ SO 61 - SEUIL CLASSIQUE

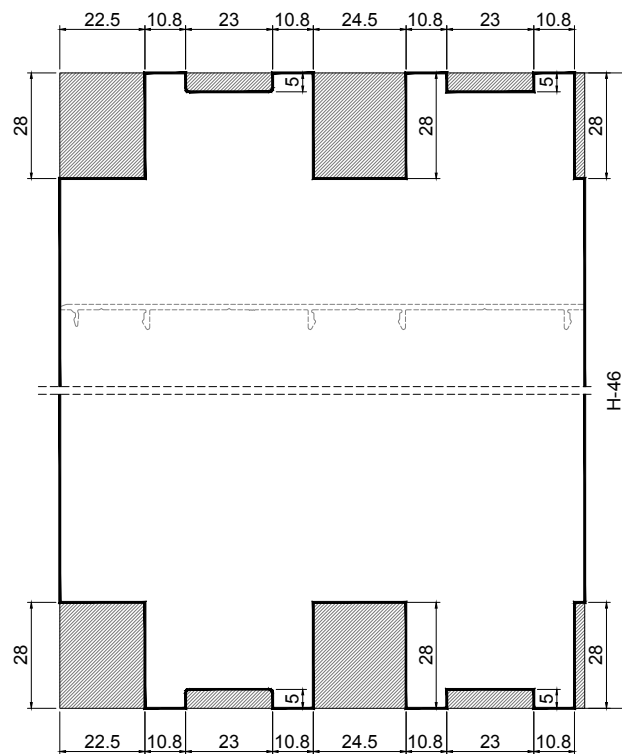
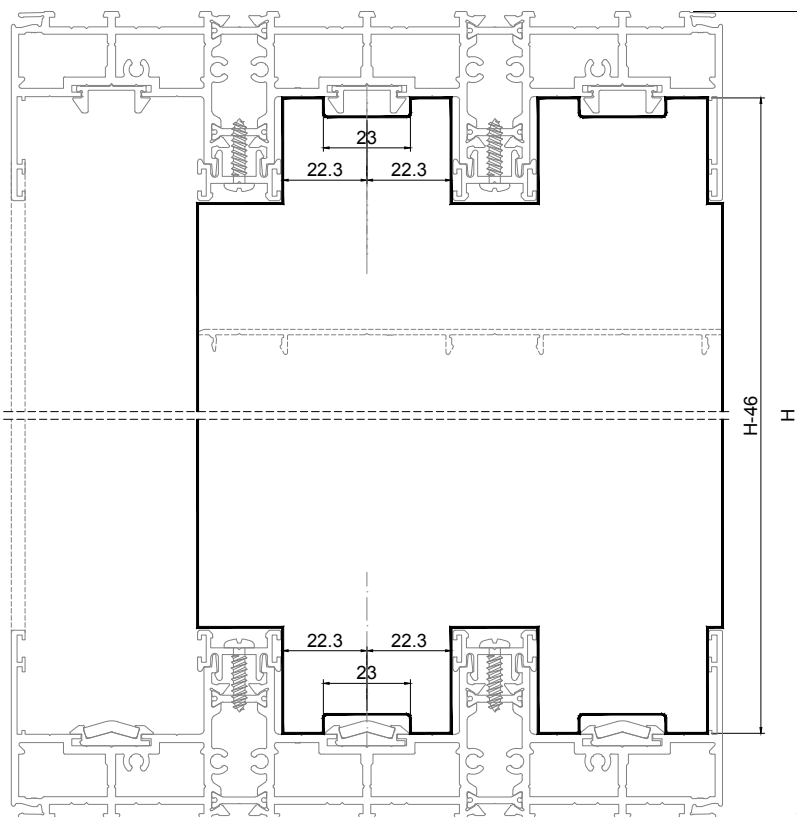

MAQUINAÇÃO E FRESAGEM DO PERFIL SO 61 - SOLEIRA OCULTA
SO 61 PROFILE MACHINING AND MILLING - CONCEALED SILL
USINAGE ET FRAISAGE DU PROFILÉ SO 61 - SEUIL CACHÉ

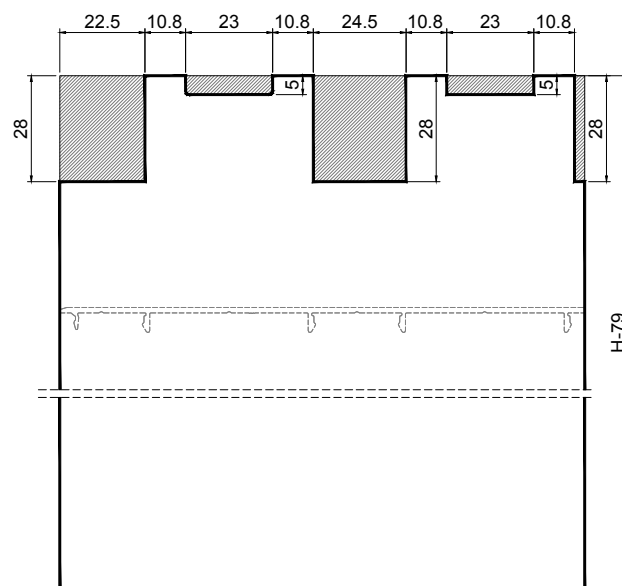
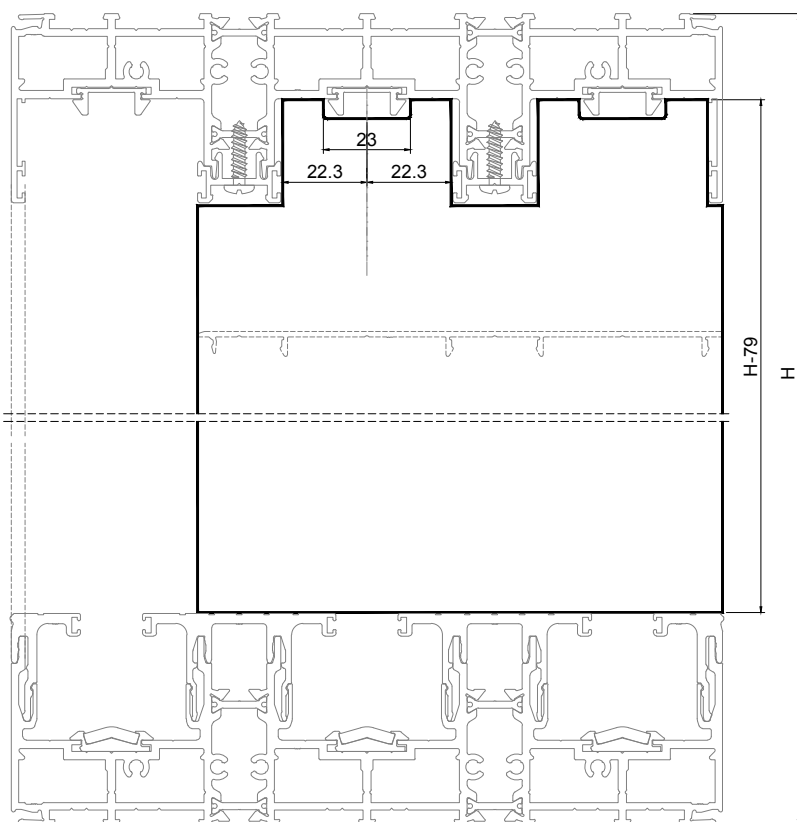

MAQUINAÇÃO E FRESAGEM DO PERFIL SO 62 - SOLEIRA TRADICIONAL
SO 62 PROFILE MACHINING AND MILLING - CLASSIC SILL
USINAGE ET FRAISAGE DU PROFILÉ SO 62 - SEUIL CLASSIQUE

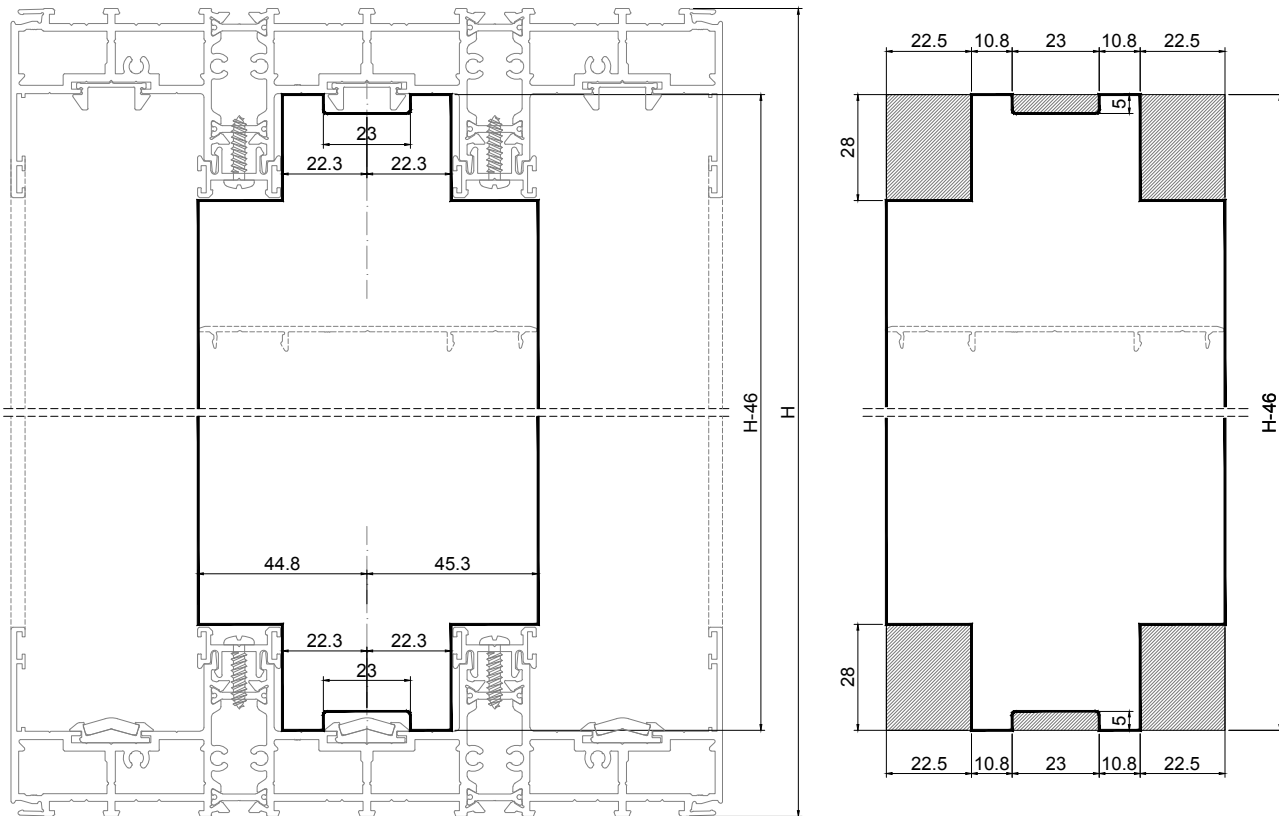

MAQUINAÇÃO E FRESAGEM DO PERFIL SO 62 - SOLEIRA OCULTA
SO 62 PROFILE MACHINING AND MILLING - CONCEALED SILL
USINAGE ET FRAISAGE DU PROFILÉ SO 62 - SEUIL CACHÉ

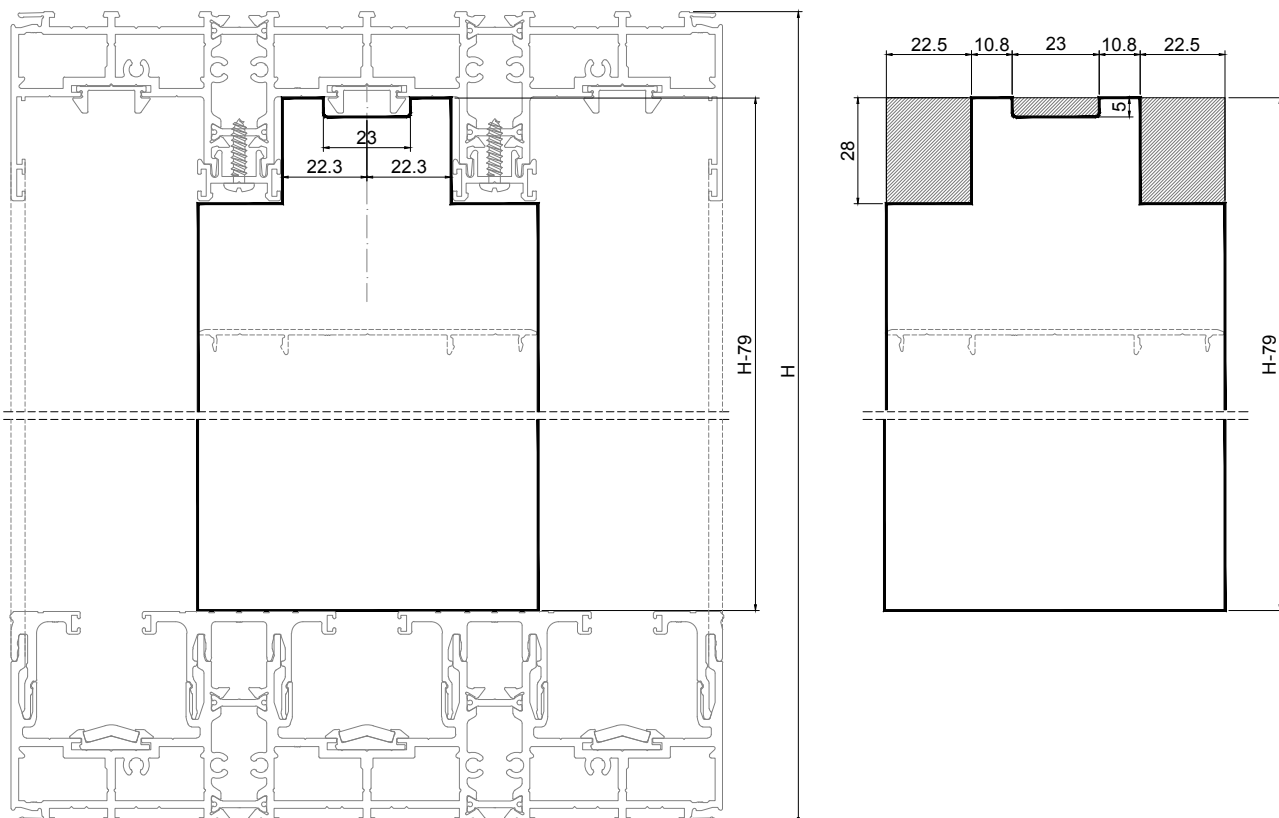

CORTE DOS PERFIS OS40 / OS41 - TIPOLOGIA 2 RAIL 2 FOLHAS

OS40 / OS41 PROFILES CUTTING - 2 RAIL 2 SASHES TYPOLOGY

COUPE DE PROFILÉS OS40 / OS41 - TYPOLOGIE 2 RAIL 2 VENTAUX

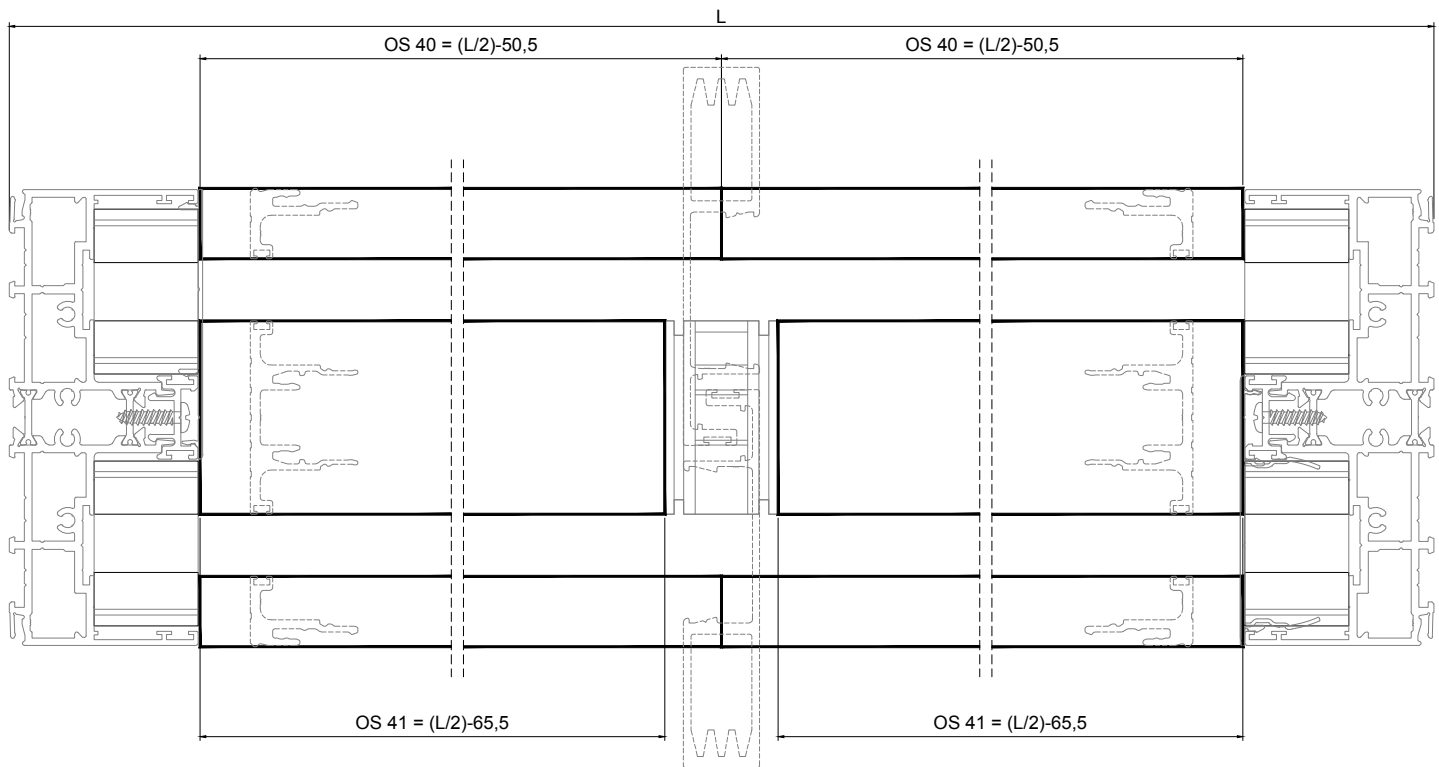

CORTE DOS PERFIS OS40 / OS41 - TIPOLOGIA 3 RAIL 3 FOLHAS

OS40 / OS41 PROFILES CUTTING - 3 RAIL 3 SASHES TYPOLOGY

COUPE DE PROFILÉS OS40 / OS41 - TYPOLOGIE 3 RAIL 3 VENTAUX

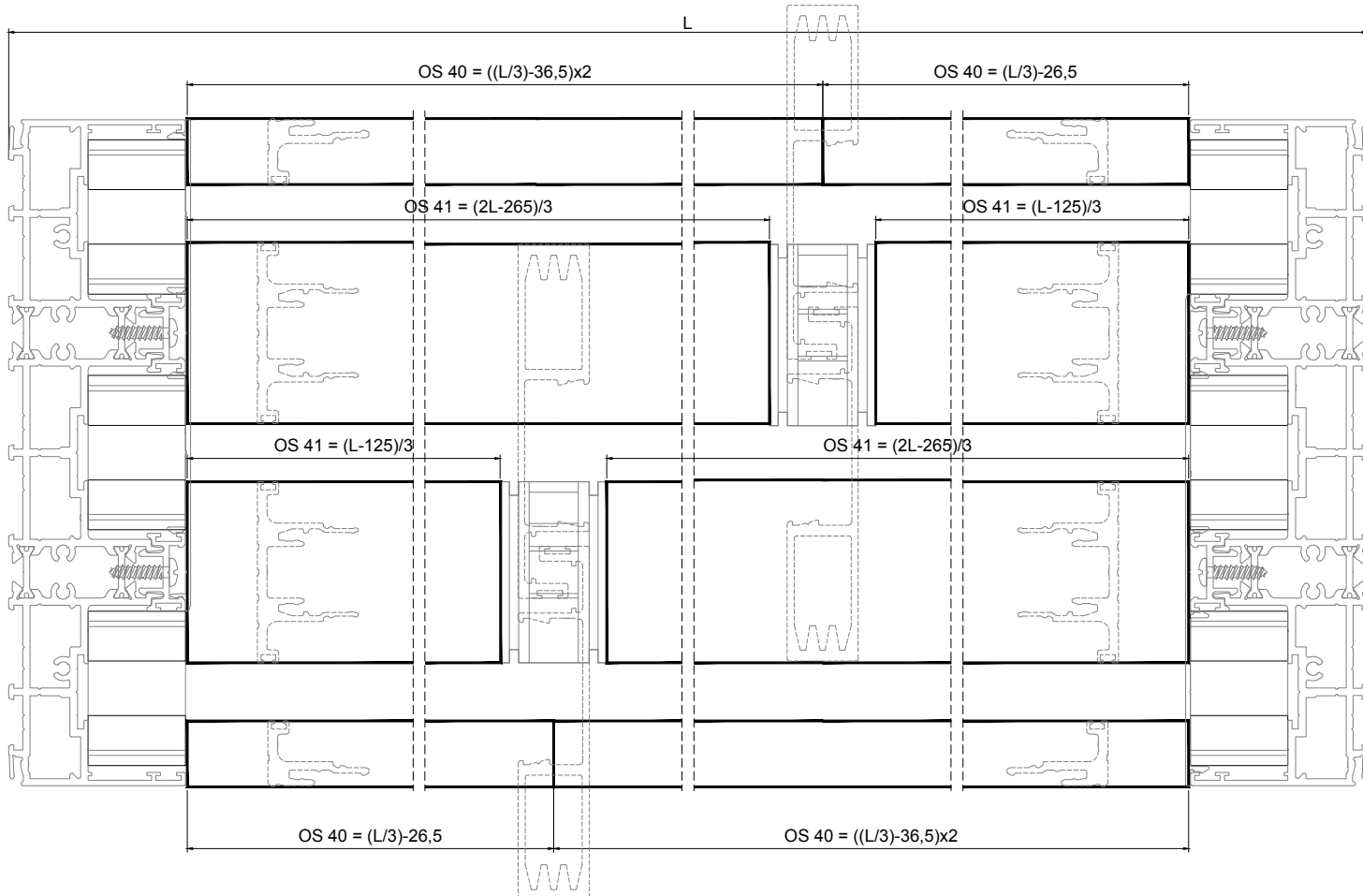

APLICAÇÃO DOS PERFIS SO 37 EM SOLUÇÕES MOTORIZADAS

SO 37 PROFILE APPLICATION FOR MOTORISED SOLUTIONS

APPLICATION DES PROFILÉS SO 37 DANS DES SOLUTIONS MOTORISÉES

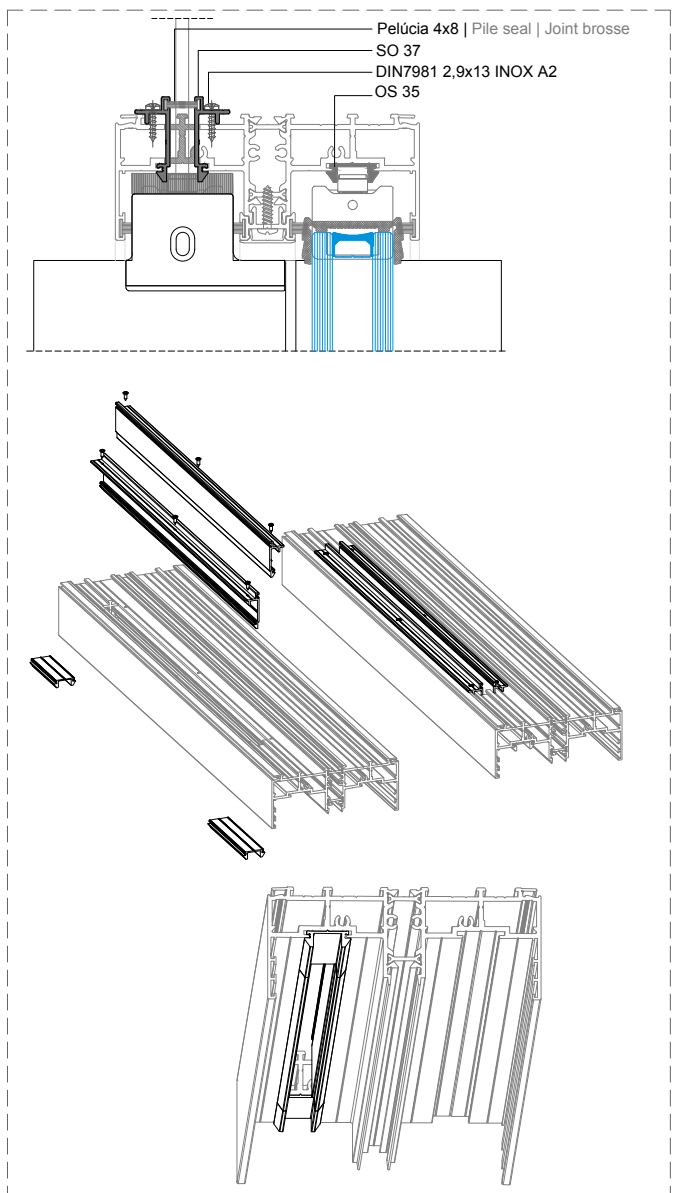
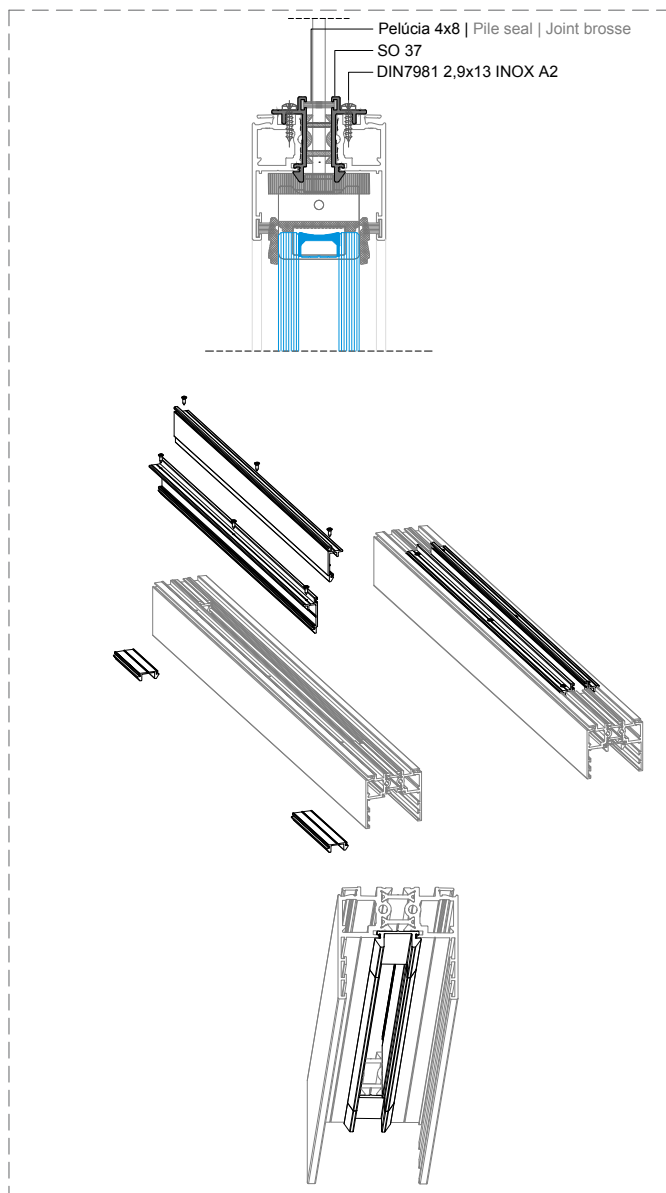
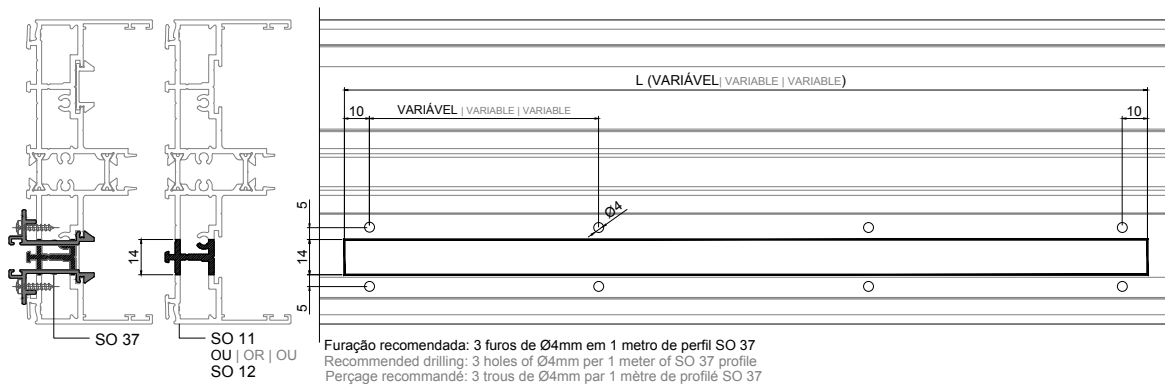
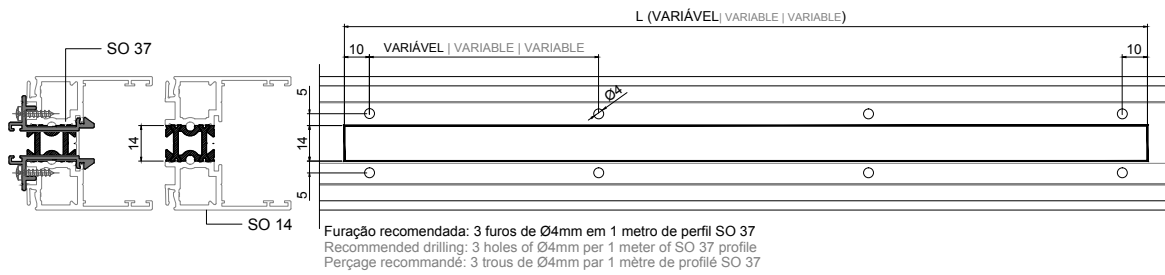

RASGOS PARA DRENAGEM / VENTILAÇÃO - OS TRADICIONAL
SLOT DRAIN WATER / VENT - OS CLASSIC
FENTES POUR DRAINAGE / VENTILATION - OS CLASSIQUE

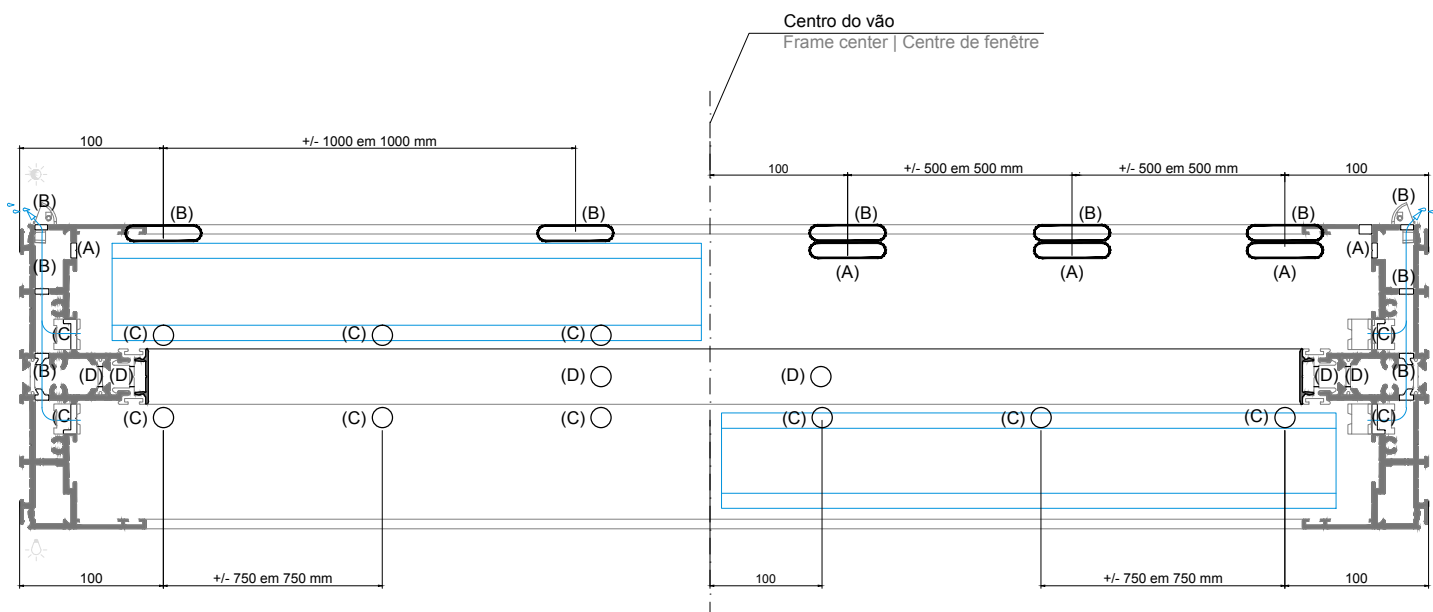
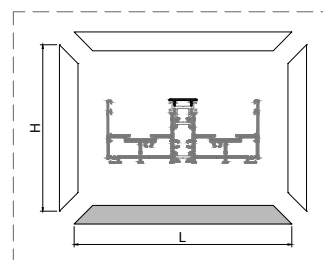
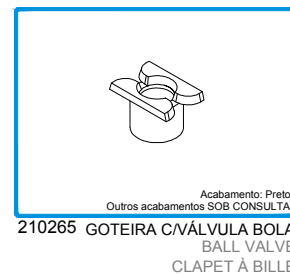
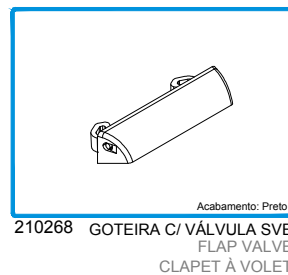
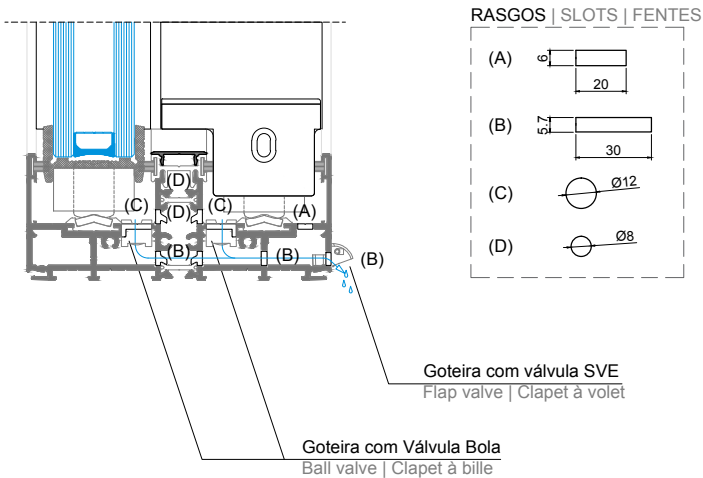

FREZAR (NÃO EXECUTÁVEL NO CORTANTE)
MILLING (NOT EXECUTABLE ON PUNCHING TOOL)
FRAISAGE (N'EST PAS EXÉCUTABLE DANS LE POINÇON)

DRENAGEM / VENTILAÇÃO - OS-TRADICIONAL
DRAIN WATER / VENT - OS-CLASSIC
DRAINAGE / VENTILATION - OS-CLASSIQUE

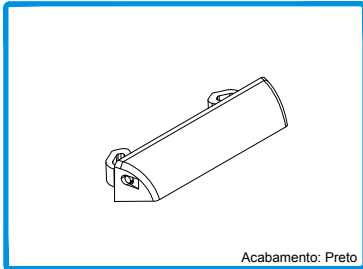

Acabamento: Preto

210268 GOTEIRA C/ VÁLVULA SVE
FLAP VALVE
CLAPET À VOILET



Acabamento: Preto
Outros acabamentos SOB CONSULTA

210265 GOTEIRA C/VÁLVULA BOLA
BALL VALVE
CLAPET À BILLE

SO 14

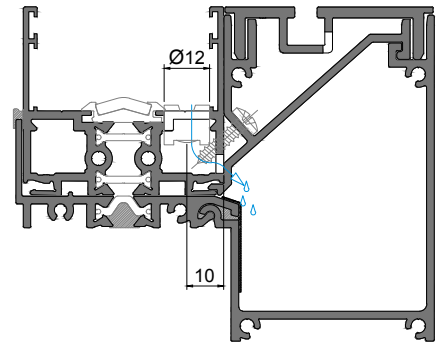

SO 11

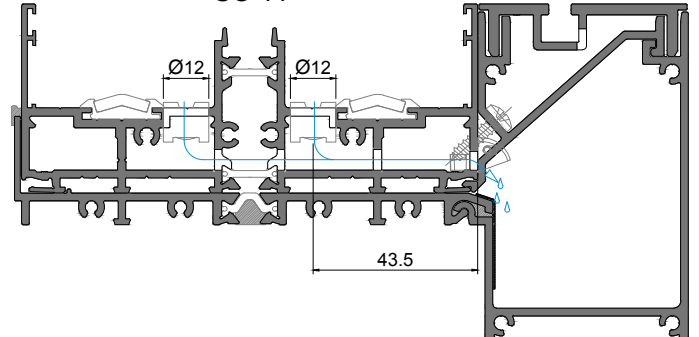

SO 12

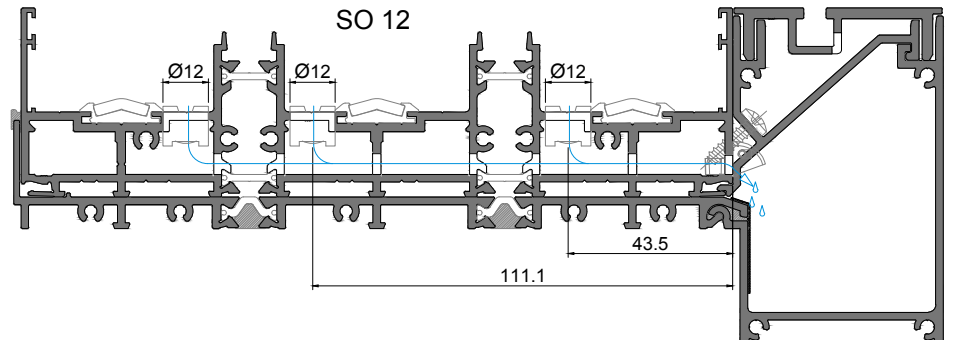

SO 13

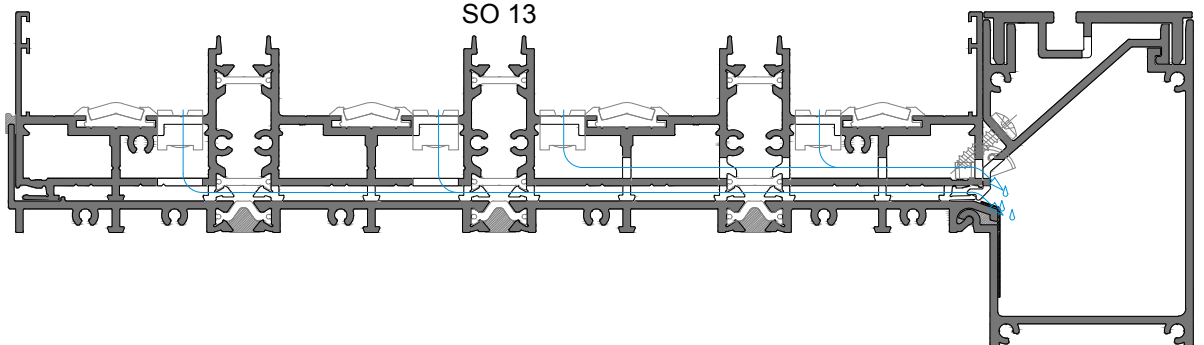

RASGOS PARA DRENAGEM / VENTILAÇÃO - OS OCULTA
SLOT DRAIN WATER / VENT - OS CONCEALED
FENTES POUR DRAINAGE / VENTILATION - OS CACHÉE

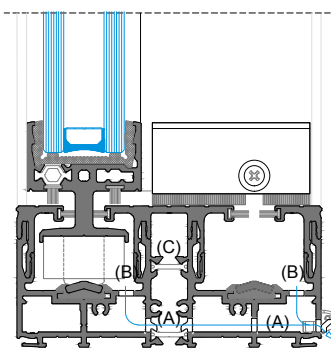

Goteira com válvula SVE
Flap valve | Clapet à volet

RASGOS | SLOTS | FENTES

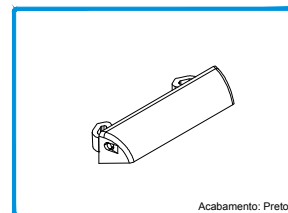
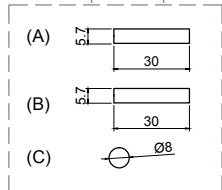

Acabamento: Preto

210268 GOTEIRA C/ VÁLVULA SVE
FLAP VALVE
CLAPET À VOILET

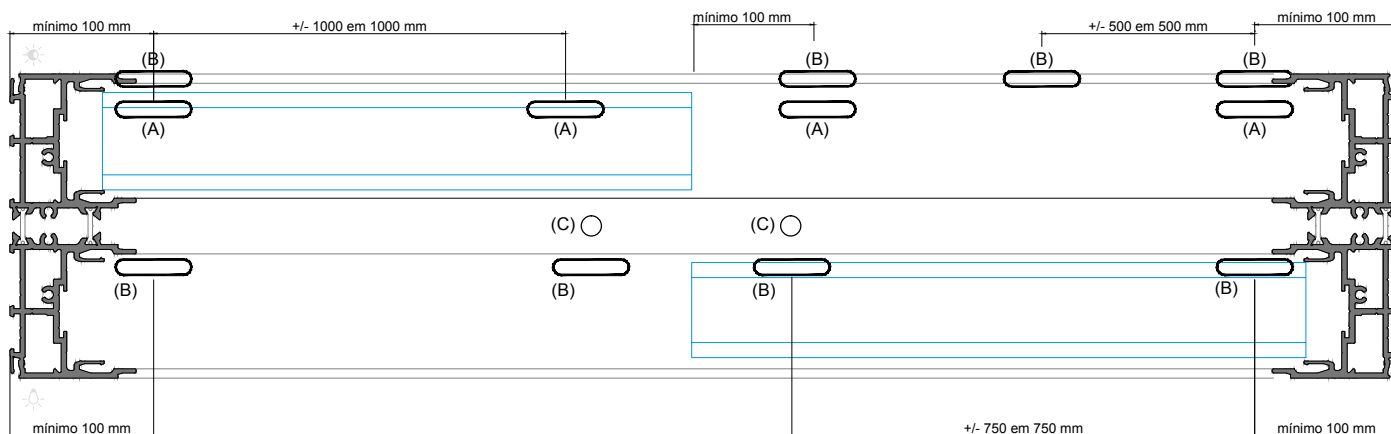
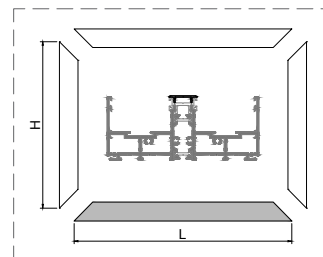

FREZAR (NÃO EXECUTÁVEL NO CORTANTE)
MILLING (NOT EXECUTABLE ON PUNCHING TOOL)
FRAISAGE (N'EST PAS EXÉCUTABLE DANS LE POINÇON)

Rasgo/Drenagem inferior - **OPCIONAL** - consultar gabinete técnico para este tipo de drenagem
Lower Slot drain water/vent - **OPTIONAL** - consult technical department for this type of drainage
Fentes pour drainage/ventilation inférieure - **OPTIONNEL** - consulter le bureau technique pour ce type de drainage

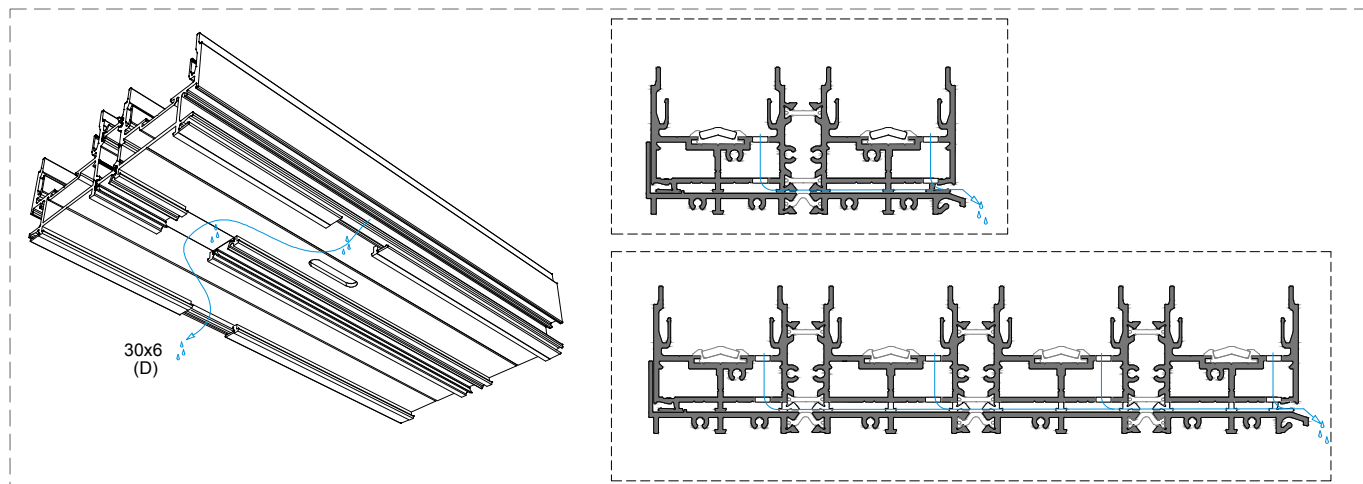

DRENAGEM / VENTILAÇÃO - OS-OCULTA
DRAIN WATER / VENT - OS-CONCEALED
DRAINAGE / VENTILATION - OS-CACHÉE

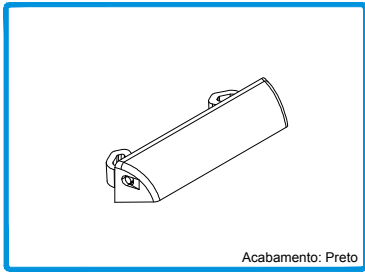

Acabamento: Preto

210268 GOTEIRA C/ VÁLVULA SVE
FLAP VALVE
CLAPET À VOILET

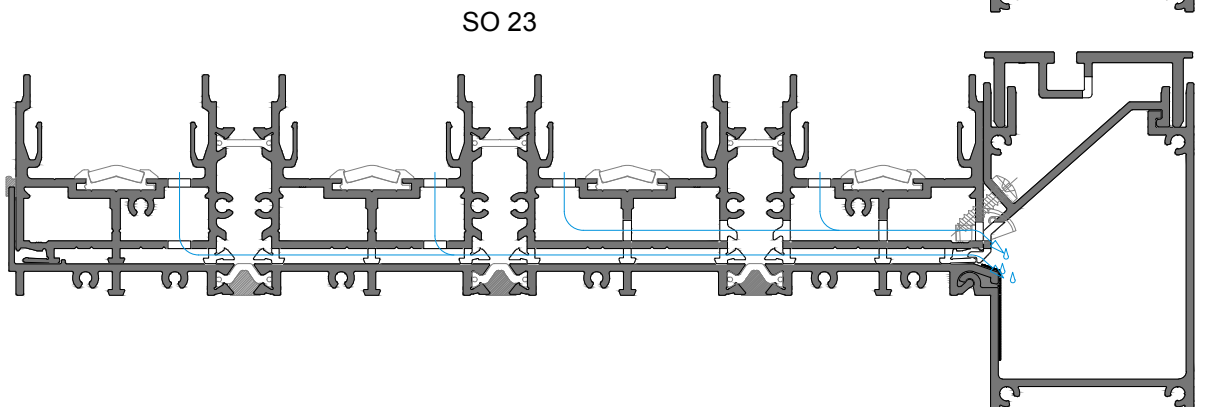
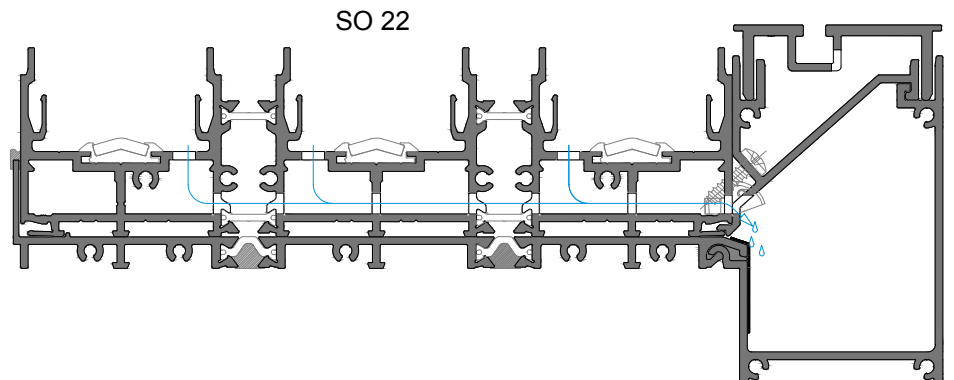
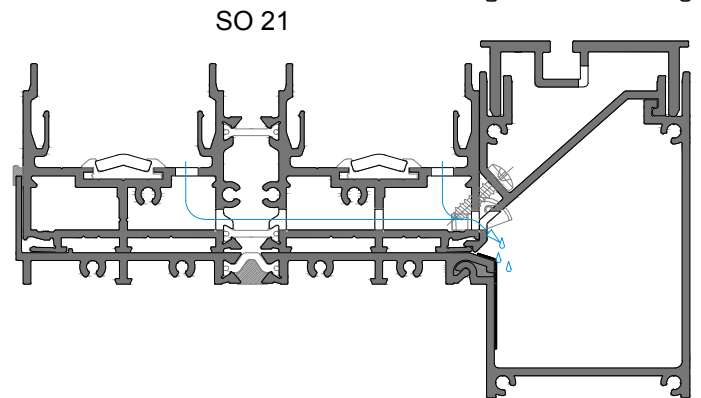
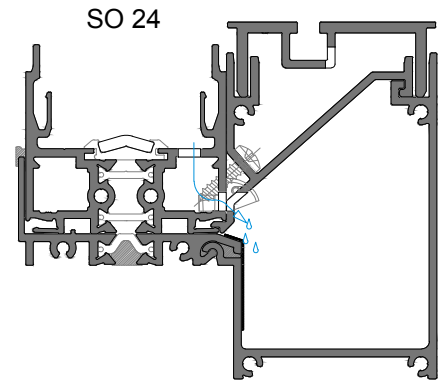

CUNHOS OS DOUBLE
CUTTING TOOL OS DOUBLE
MATRICE DE DÉCOUPAGE

Operações diversas | Several operations | Operations Diverses

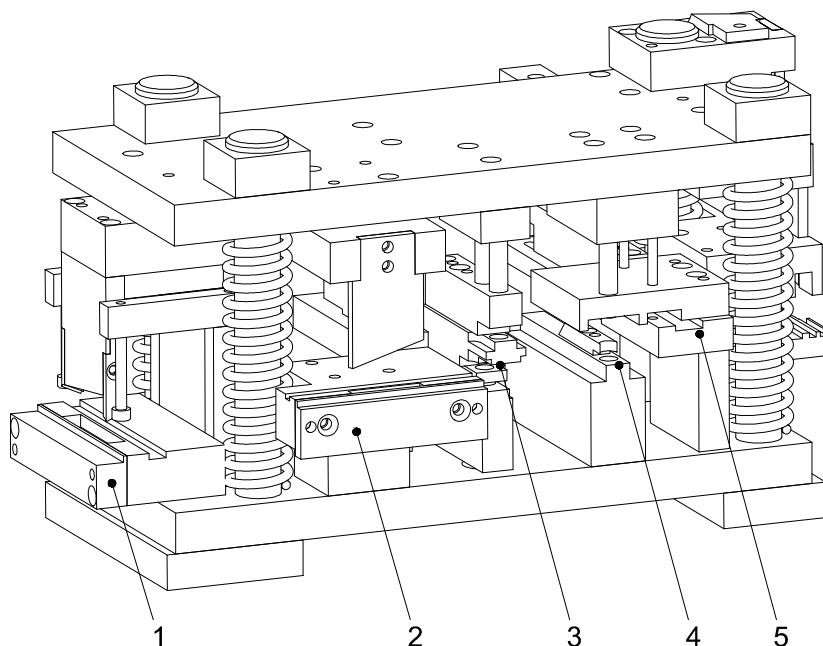
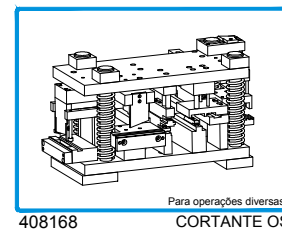

OPERAÇÃO 6
CUT 6
USINAGE 6

<p>Peça larga Large piece long pièce</p>	<p>Peça curta short piece court pièce</p>
---	--

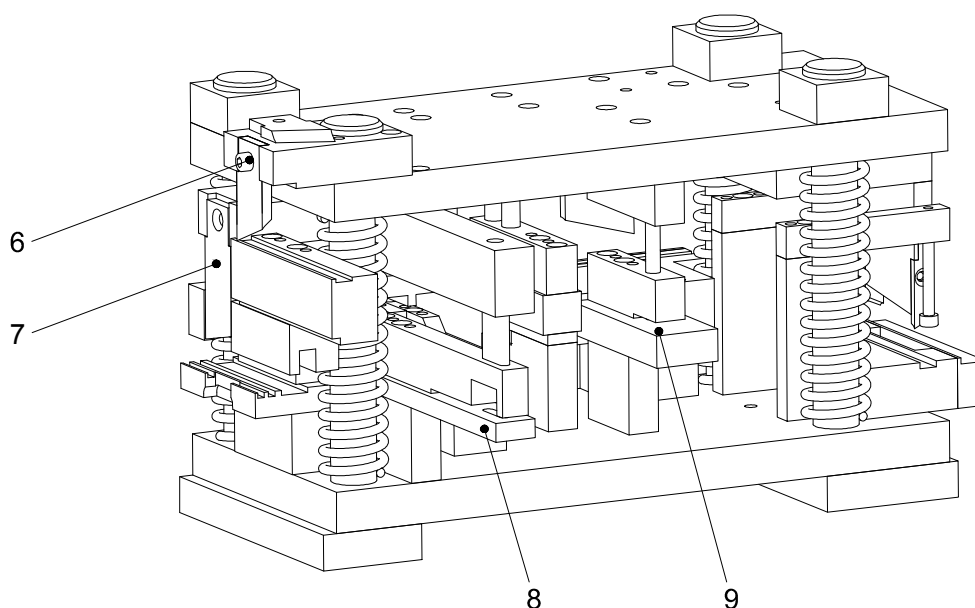

CUNHOS OS DOUBLE
CUTTING TOOL OS DOUBLE
MATRICE DE DÉCOUPAGE

Operações diversas | Several operations | Operations Diverses

OPERAÇÃO 1 | CUT 1 | USINAGE 1

MAQUINAÇÃO NA POLIAMIDA PARA FECHO LATERAL
POLYAMIDE MACHINING FOR LATERAL LOCK
USINAGE DE POLYAMIDE POUR FERMETURE LATÉRALE

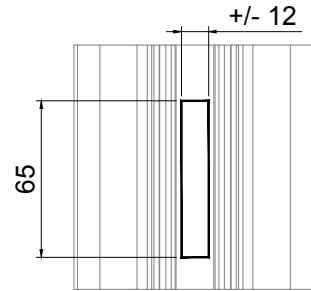
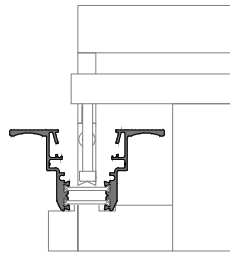

OPERAÇÃO 2 | CUT 2 | USINAGE 2

MAQUINAÇÃO PARA FECHO LATERAL
MACHINING FOR LATERAL LOCK
USINAGE POUR FERMETURE LATÉRALE

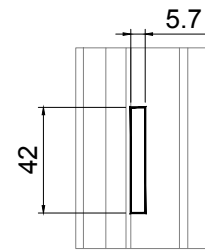
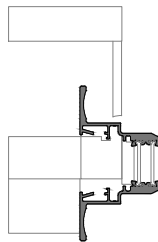

OPERAÇÃO 3 | CUT 3 | USINAGE 3

MAQUINAÇÃO PARA TOPOS LATERAIS
MACHINING FOR LATERAL END CAPS
USINAGE POUR LATÉRALE BOUCHON

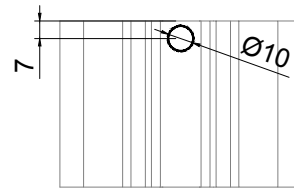
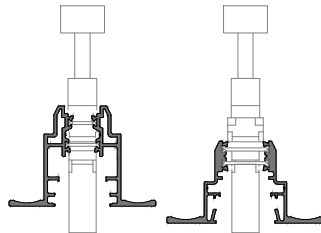

OPERAÇÃO 4 | CUT 4 | USINAGE 4

MAQUINAÇÃO PARA MOLLA DE RETENÇÃO (posterior à MAQUINAÇÃO 1)
MACHINING FOR RETENTION SPRING (after cutting 1)
USINAGE POUR RESSORT DE RETENTION (après usinage 1)

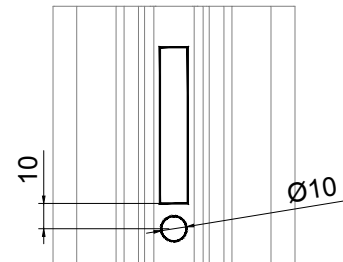
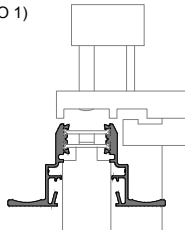

OPERAÇÃO 5 | CUT 5 | USINAGE 5

MAQUINAÇÃO DA VARETA
ROD MACHINING
USINAGE DE LA CREMONE

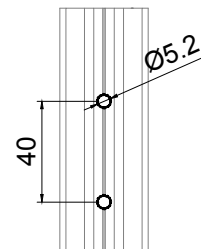
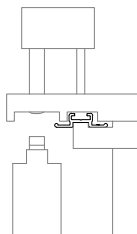

OPERAÇÃO 9 | CUT 9 | USINAGE 9

MAQUINAÇÃO DOS TOPOS CENTRAI SOLEIRA OCULTA
MACHINING OF THE CENTRAL TOPS CONCEALED SILL
USINAGE DU BOUCHON CENTRAL SEUIL CACHÉ

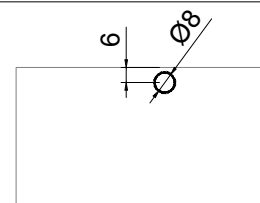
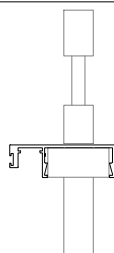

CORTE E MAQUINAÇÃO DOS PERFIS LAT. SO 64/65/66 - SOLEIRA TRADICIONAL

CUTTING AND MACHINING FOR LATERAL PROFILES SO 64/65/66 - CLASSIC SILL

COUPE ET USINAGE POUR PROFILÉS LATÉRAUX SO 64/65/66 - SEUIL CLASSIQUE

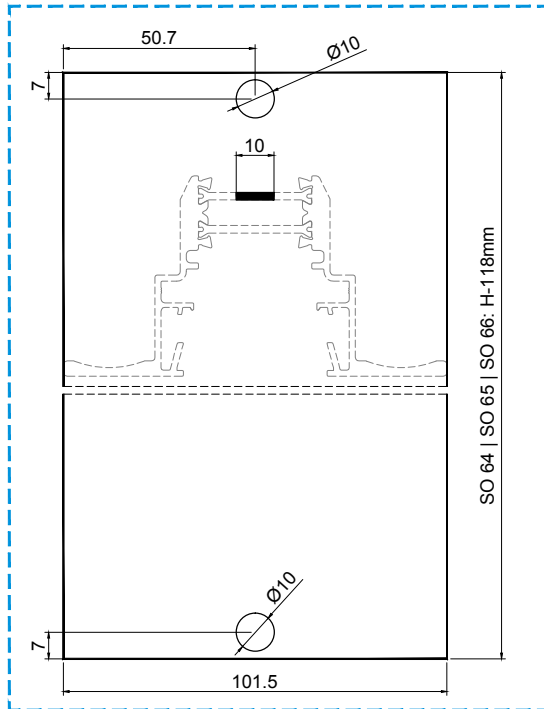

Furação realizada no Cortante
Drilling performed on Punching tool
Forage réalisée dans le Poinçon

CORTE E MAQUINAÇÃO DOS PERFIS LAT. SO 64/65/66 - SOLEIRA OCULTA

CUTTING AND MACHINING FOR LATERAL PROFILES SO 64/65/66 - CONCEALED SILL

COUPE ET USINAGE POUR PROFILÉS LATÉRAUX SO 64/65/66 - SEUIL CACHÉ

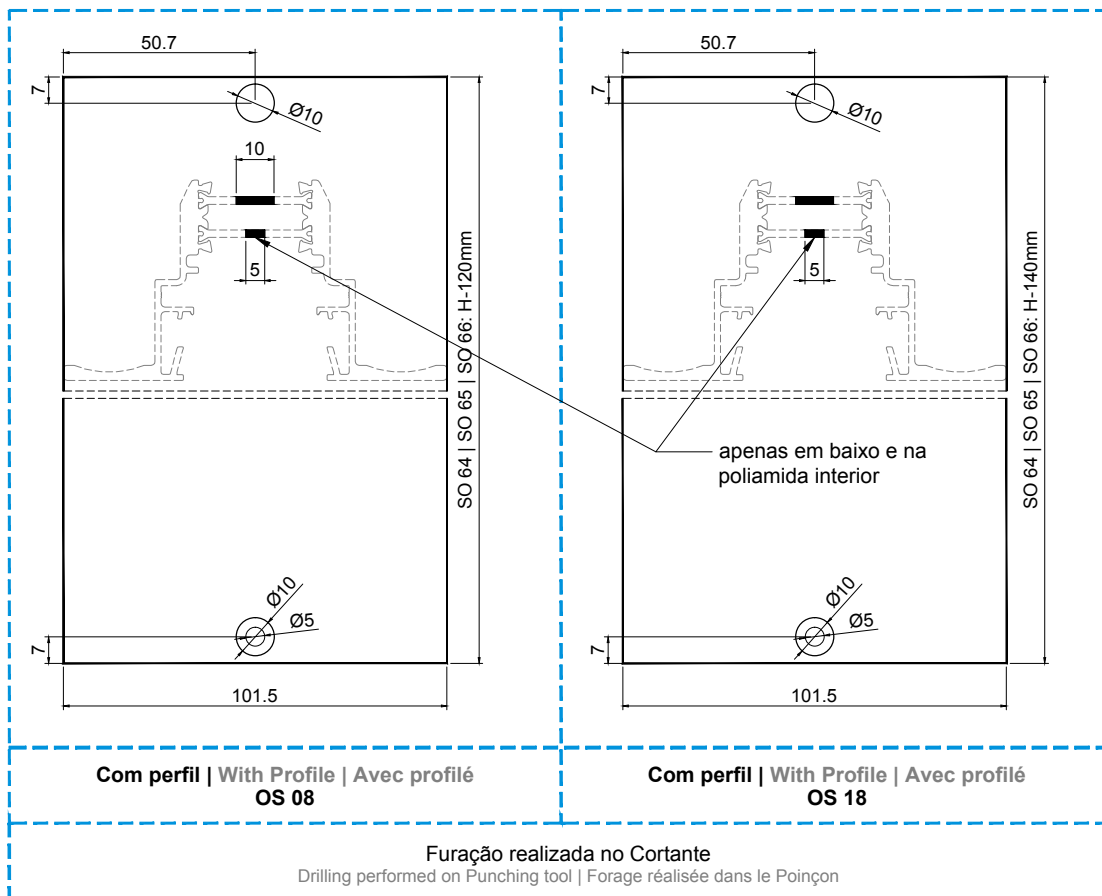

CORTE E MAQUINAÇÃO DOS PERFIS LAT. SO 03 - SOLEIRA TRADICIONAL
CUTTING AND MACHINING FOR LATERAL PROFILES SO 03 - CLASSIC SILL
COUPE ET USINAGE POUR PROFILÉS LATÉRAUX SO 03 - SEUIL CLASSIQUE

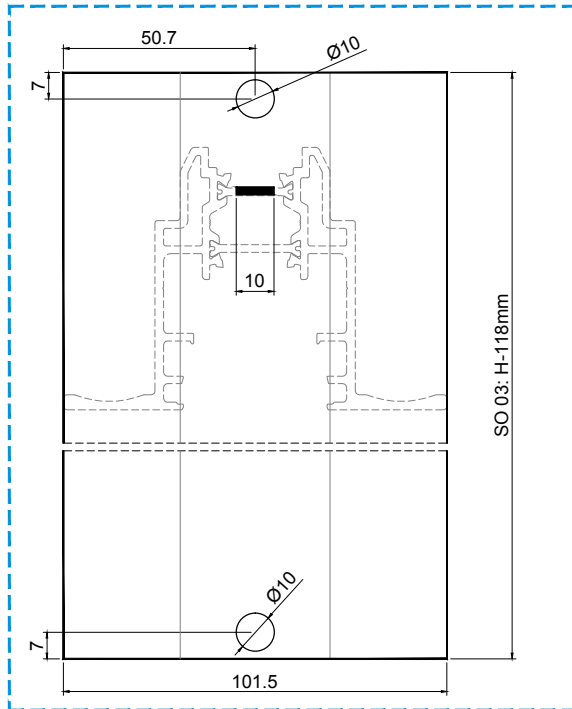

Furação realizada no Cortante
Drilling performed on Punching tool
Forage réalisée dans le Poinçon

CORTE E MAQUINAÇÃO DOS PERFIS LAT. SO 03 - SOLEIRA OCULTA
CUTTING AND MACHINING FOR LATERAL PROFILES SO 03 - CONCEALED SILL
COUPE ET USINAGE POUR PROFILÉS LATÉRAUX SO 03 - SEUIL CACHÉ

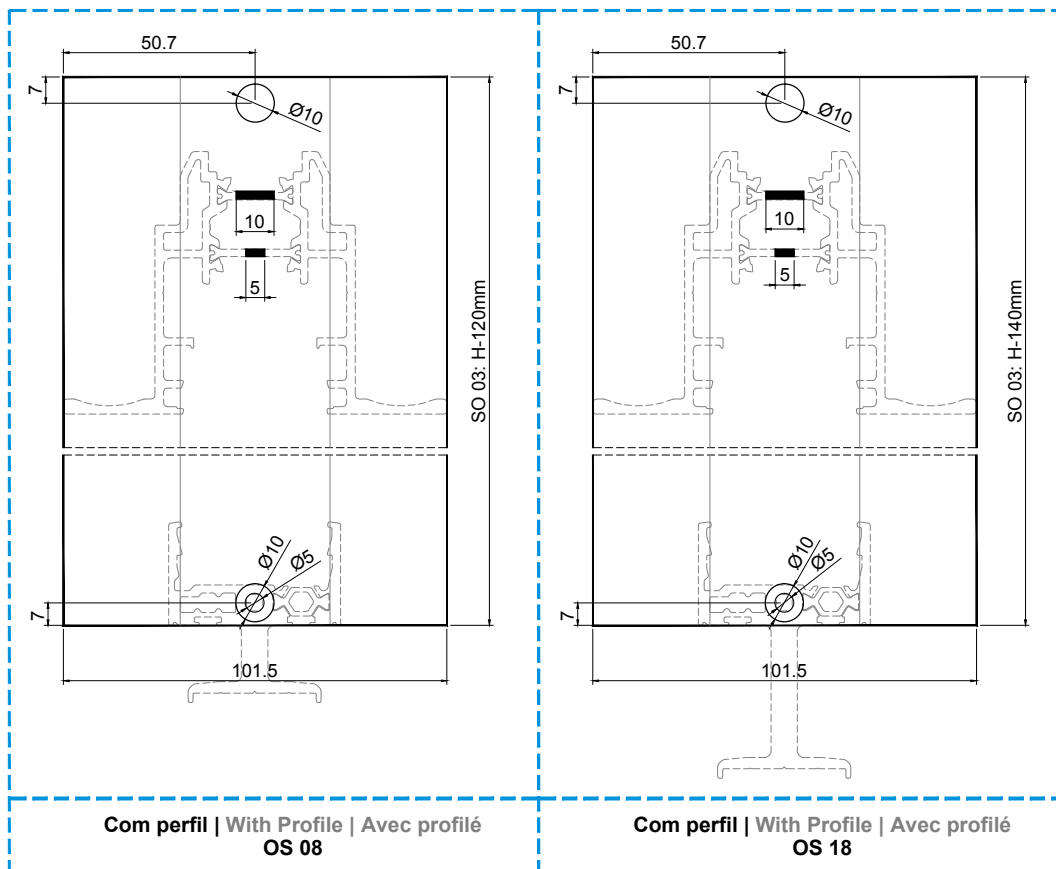

Com perfil | With Profile | Avec profilé
OS 08

Com perfil | With Profile | Avec profilé
OS 18

Furação realizada no Cortante
Drilling performed on Punching tool
Forage réalisée dans le Poinçon

CORTE E MAQUINAÇÃO DOS PERFIS CENTRAIS OS 11/51/61 - SOLEIRA TRADICIONAL

CUTTING AND MACHINING FOR CENTRAL PROFILES OS 11/51/61 - CLASSIC SILL

COUPE ET USINAGE POUR PROFILÉS CENTRAUX OS 11/51/61 - SEUIL CLASSIQUE

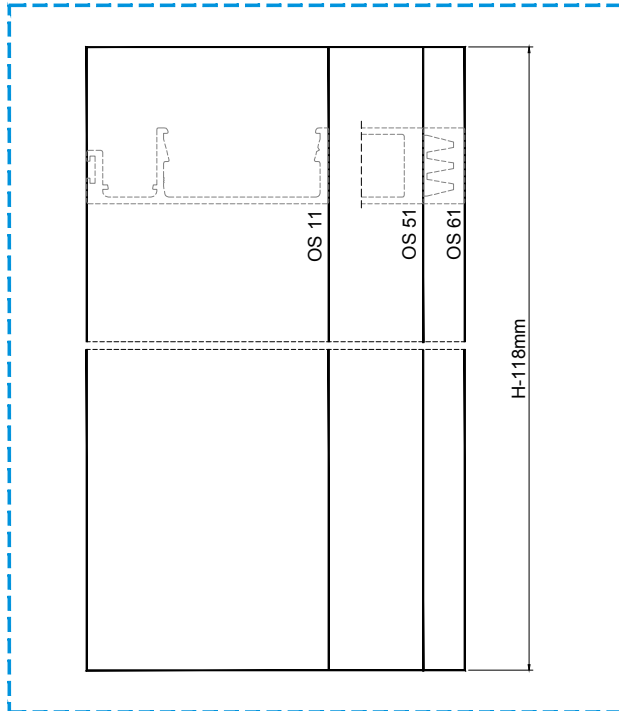

Perfis centrais sem maquinações
Central profiles without machining
Profils centraux sans usinage

CORTE E MAQUINAÇÃO DOS PERFIS CENTRAIS OS 11/51/61 - SOLEIRA OCULTA

CUTTING AND MACHINING FOR CENTRAL PROFILES OS 11/51/61 - CONCEALED SILL

COUPE ET USINAGE POUR PROFILÉS CENTRAUX OS 11/51/61 - SEUIL CACHÉE

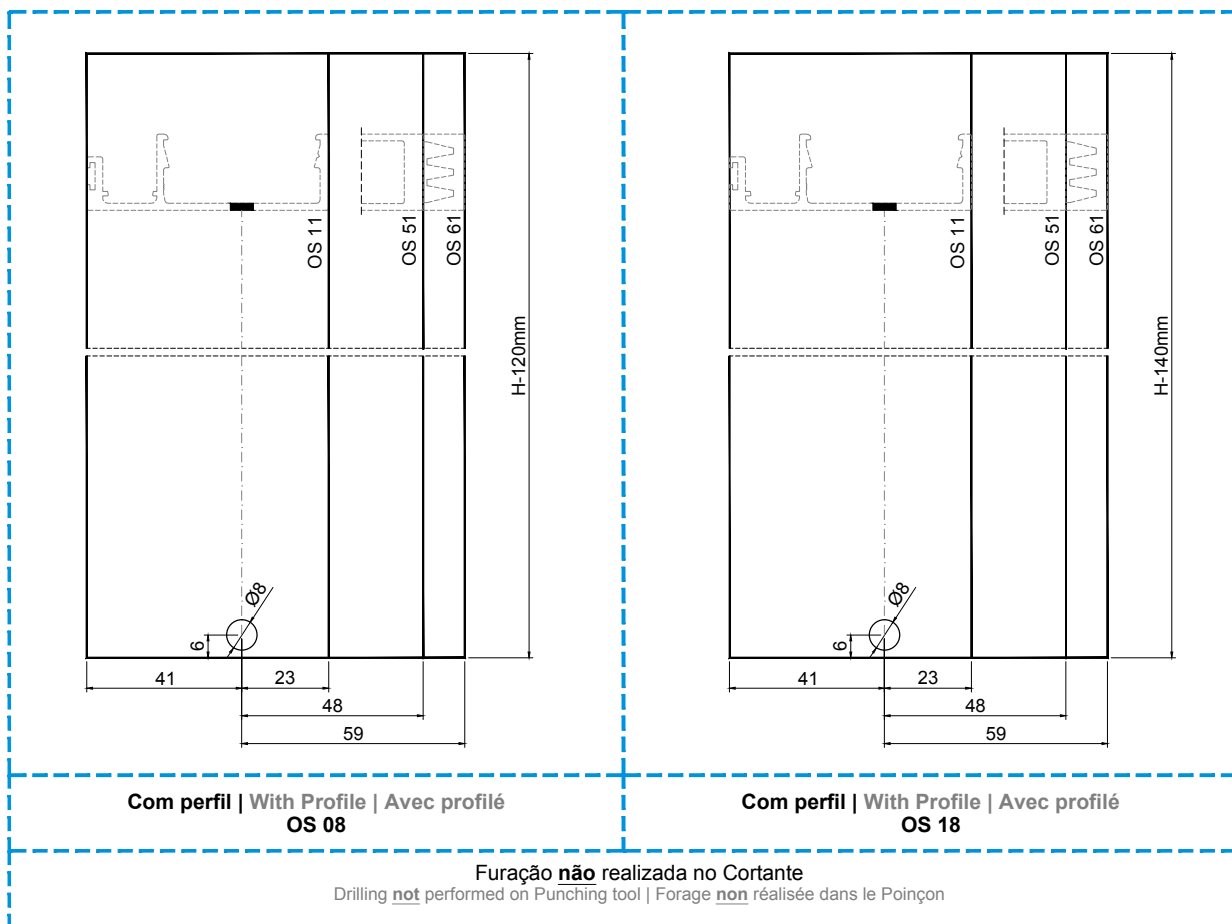

Com perfil | With Profile | Avec profilé
OS 08

Com perfil | With Profile | Avec profilé
OS 18

Furação **não** realizada no Cortante
Drilling **not** performed on Punching tool | Forage **non** réalisée dans le Poinçon

CORTE E MAQUINAÇÃO DOS PERFIS CENTRAIS OS 17/67 - SOLEIRA TRADICIONAL
CUTTING AND MACHINING FOR CENTRAL PROFILES OS 17/67 - CLASSIC SILL
COUPE ET USINAGE POUR PROFILÉS CENTRAUX OS 17/67 - SEUIL CLASSIQUE

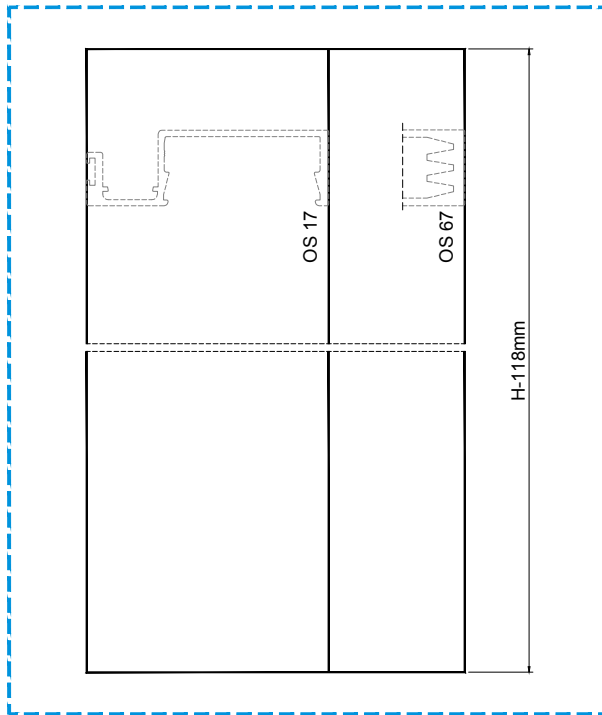

Perfis centrais sem maquinações
Central profiles without machining
Profils centraux sans usinage

CORTE E MAQUINAÇÃO DOS PERFIS CENTRAIS OS 17/67 - SOLEIRA OCULTA
CUTTING AND MACHINING FOR CENTRAL PROFILES OS 17/67 - CONCEALED SILL
COUPE ET USINAGE POUR PROFILÉS CENTRAUX OS 17/67 - SEUIL CACHÉE

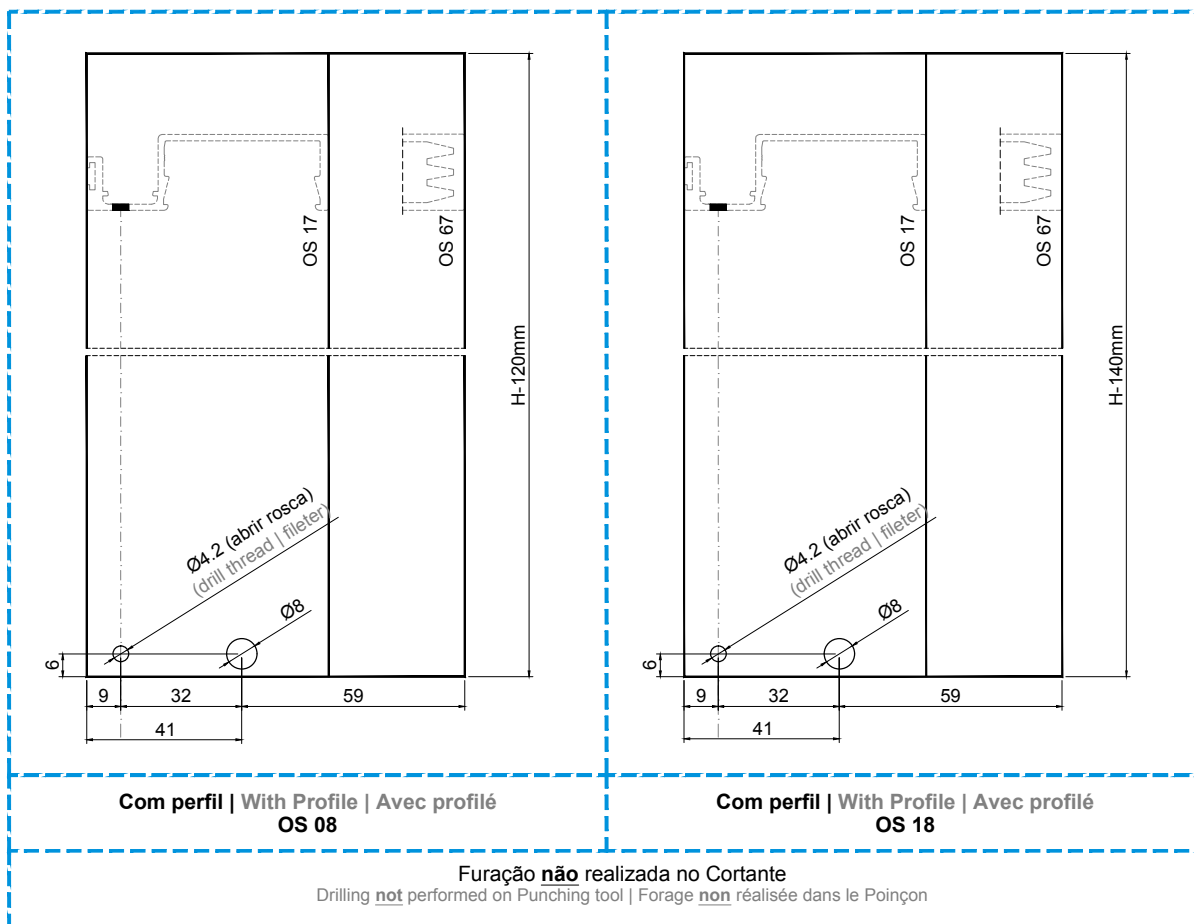

Com perfil | With Profile | Avec profilé
OS 08

Com perfil | With Profile | Avec profilé
OS 18

Furação **não** realizada no Cortante
Drilling **not** performed on Punching tool | Forage **non** réalisée dans le Poinçon

CORTE E MAQUINAÇÃO DO PERFIL UNIÃO 3/4 FOLHAS OS 27 - SOLEIRA TRADICIONAL

CUTTING AND MACHINING FOR 3/4 SASHES CONNECTION PROFILE OS 27 - CLASSIC SILL

COUPE ET USINAGE POUR PROFILÉ CONNEXION 3/4 VENTAUX OS 27 - SEUIL CLASSIQUE

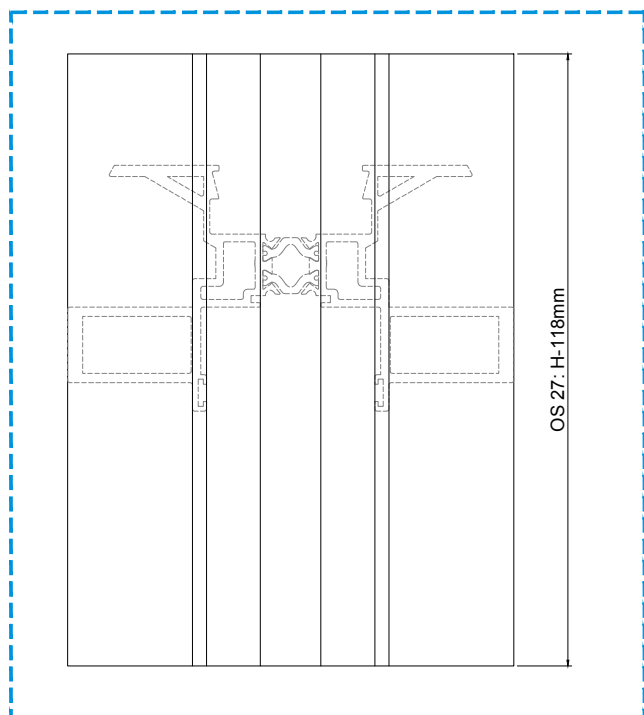

Perfil central sem maquinações

Central profile without machining

Profilé central sans usinage

CORTE E MAQUINAÇÃO DO PERFIL UNIÃO 3/4 FOLHAS OS 27 - SOLEIRA OCULTA

CUTTING AND MACHINING FOR 3/4 SASHES CONNECTION PROFILE OS 27 - CONCEALED SILL

COUPE ET USINAGE POUR PROFILÉ CONNEXION 3/4 VENTAUX OS 27 - SEUIL CACHÉ

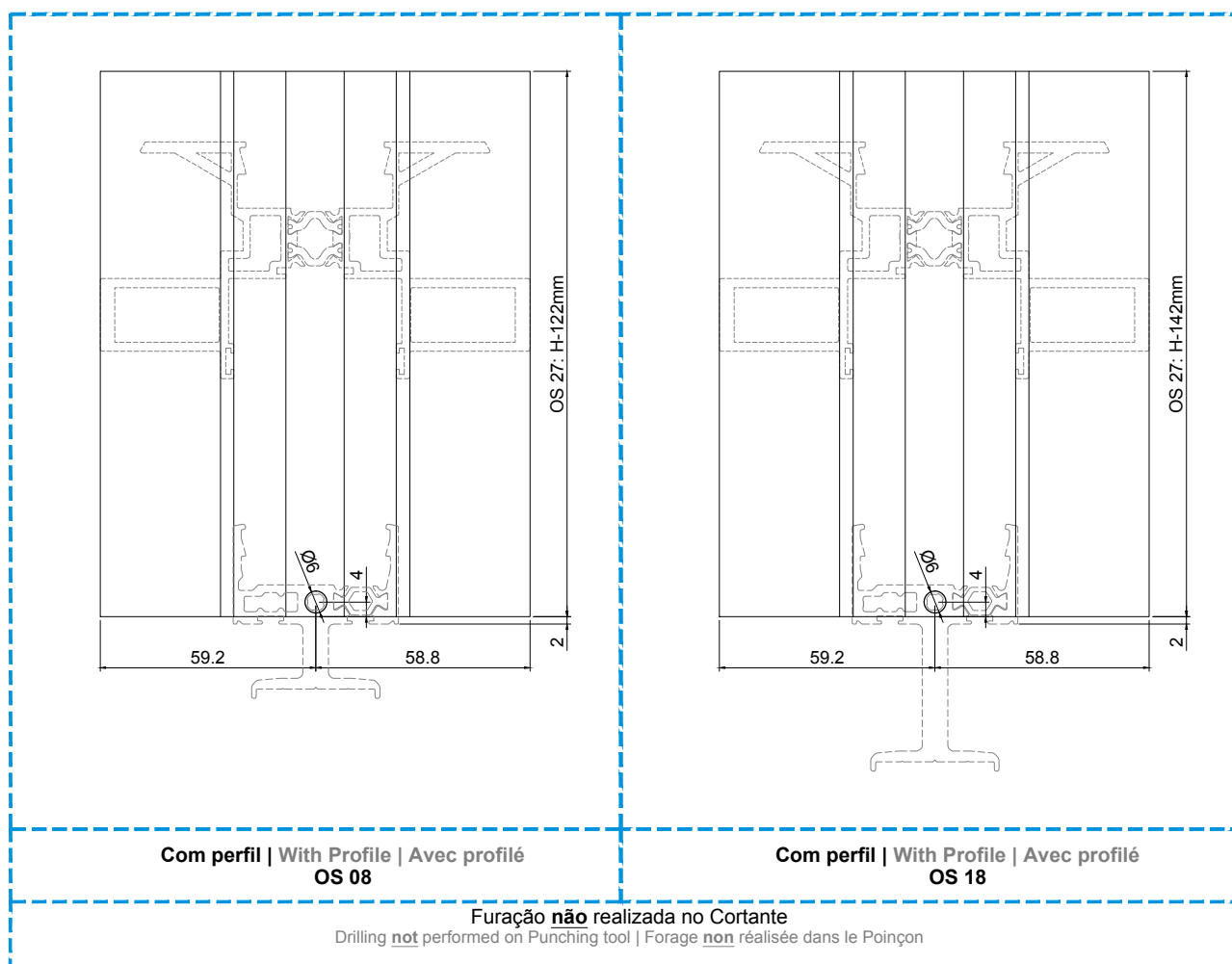

**Com perfil | With Profile | Avec profilé
OS 08**

**Com perfil | With Profile | Avec profilé
OS 18**

Furação **não** realizada no Cortante

Drilling **not** performed on Punching tool | Forage **non** réalisée dans le Poinçon

CORTE E MAQUINAÇÃO DOS PERFIS UNIÃO 3/4 FOLHAS SO 38 E SO 39 - SOLEIRA TRADICIONAL
CUTTING AND MACHINING FOR 3/4 SASHES CONNECTION PROFILES SO 38 AND SO 39 - CLASSIC SILL
COUPE ET USINAGE POUR PROFILÉS DE CONNEXION 3/4 VENTAUX SO 38 ET SO 39 - SEUIL CLASSIQUE

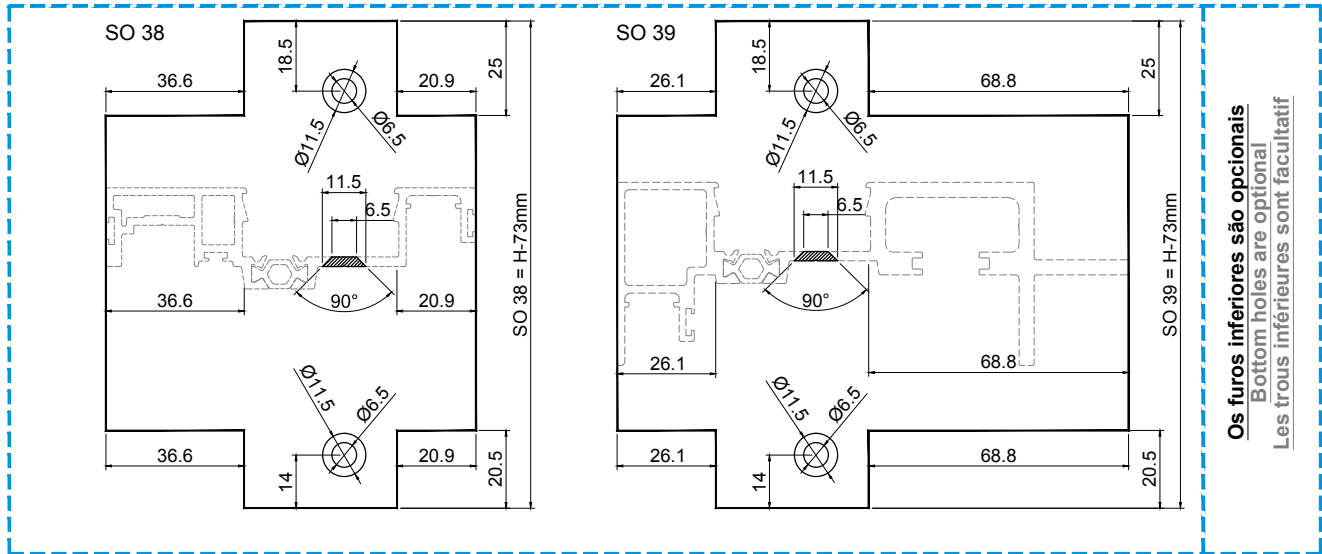

CORTE E MAQUINAÇÃO DOS PERFIS UNIÃO 3/4 FOLHAS SO 38 E SO 39 - SOLEIRA OCULTA
CUTTING AND MACHINING FOR 3/4 SASHES CONNECTION PROFILES SO 38 AND SO 39 - CONCEALED SILL
COUPE ET USINAGE POUR PROFILÉS DE CONNEXION 3/4 VENTAUX SO 38 ET SO 39 - SEUIL CACHÉ

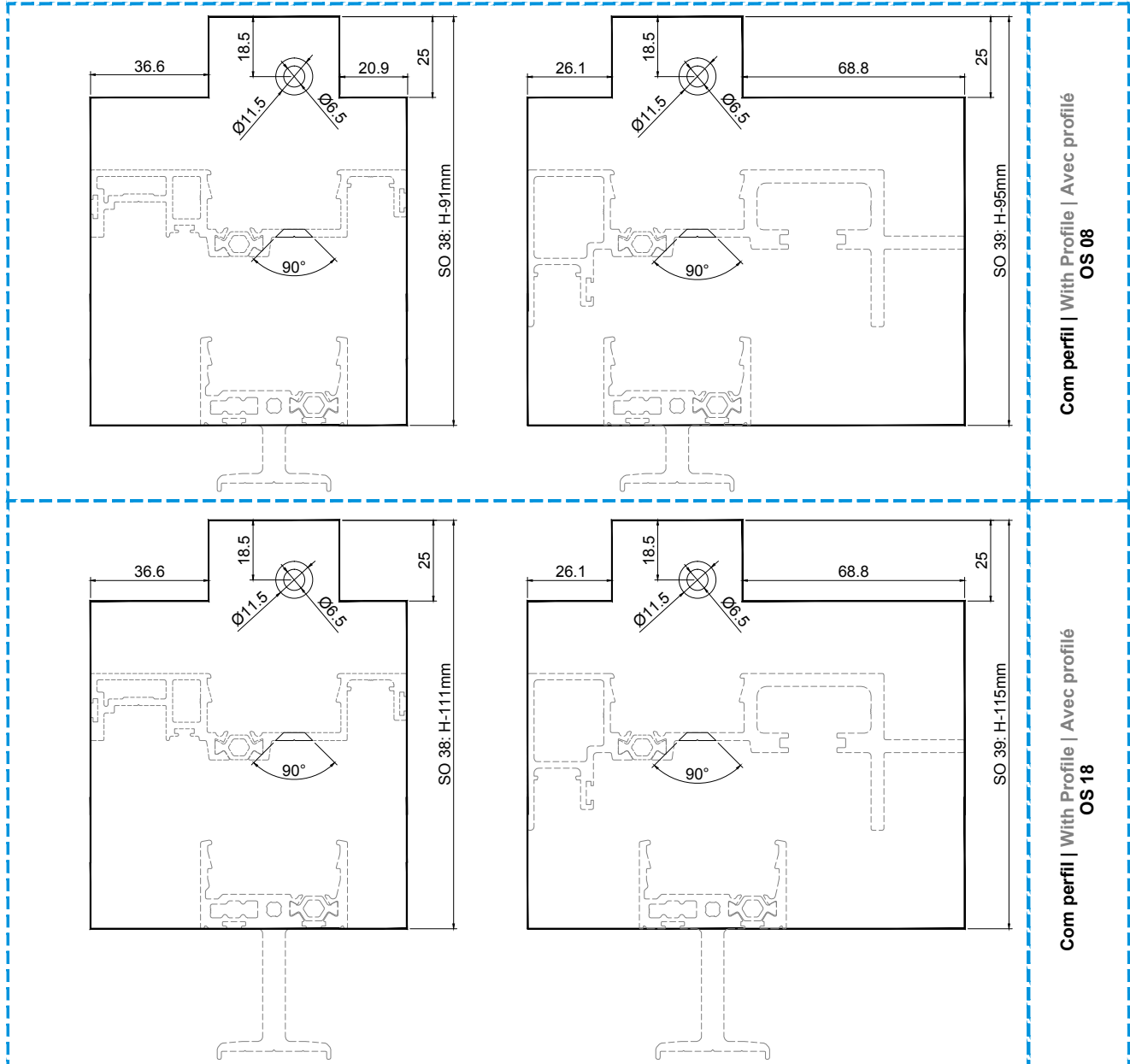

MEDIDA DE CORTE SO 33, SO 38 E SO 39 - SOLEIRA TRADICIONAL
CUTTING MEASURE SO 33, SO 38 AND SO 39 - CLASSIC SILL
MESURE DE COUPE SO 33, SO 38 ET SO 39 - SEUIL CLASSIQUE

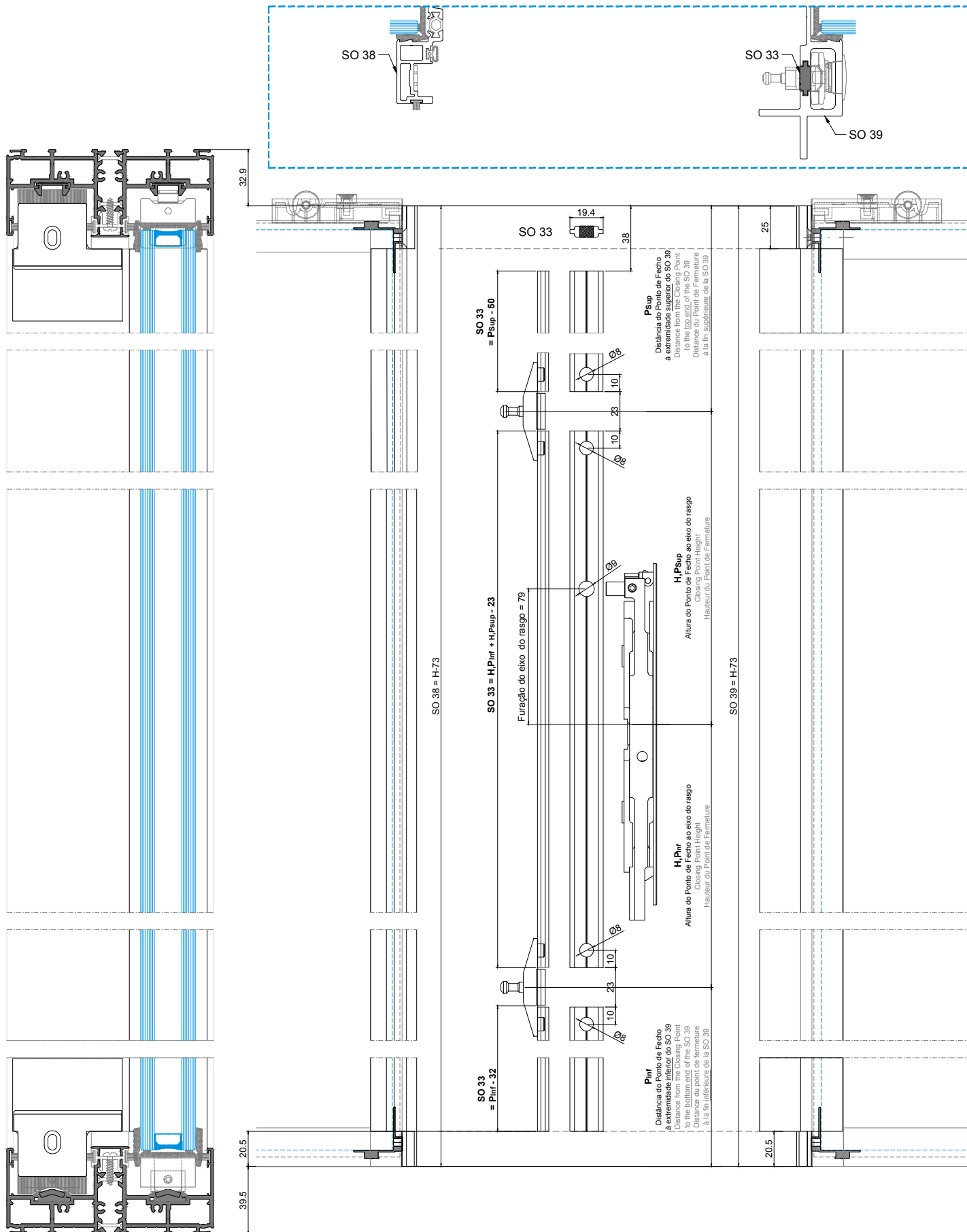

MEDIDA DE CORTE SO 33, SO 38 E SO 39 - SOLEIRA OCULTA OS 08
CUTTING MEASURE SO 33, SO 38 AND SO 39 - CONCEALED SILL OS 08
MESURE DE COUPE SO 33, SO 38 ET SO 39 - SEUIL CACHÉ OS 08

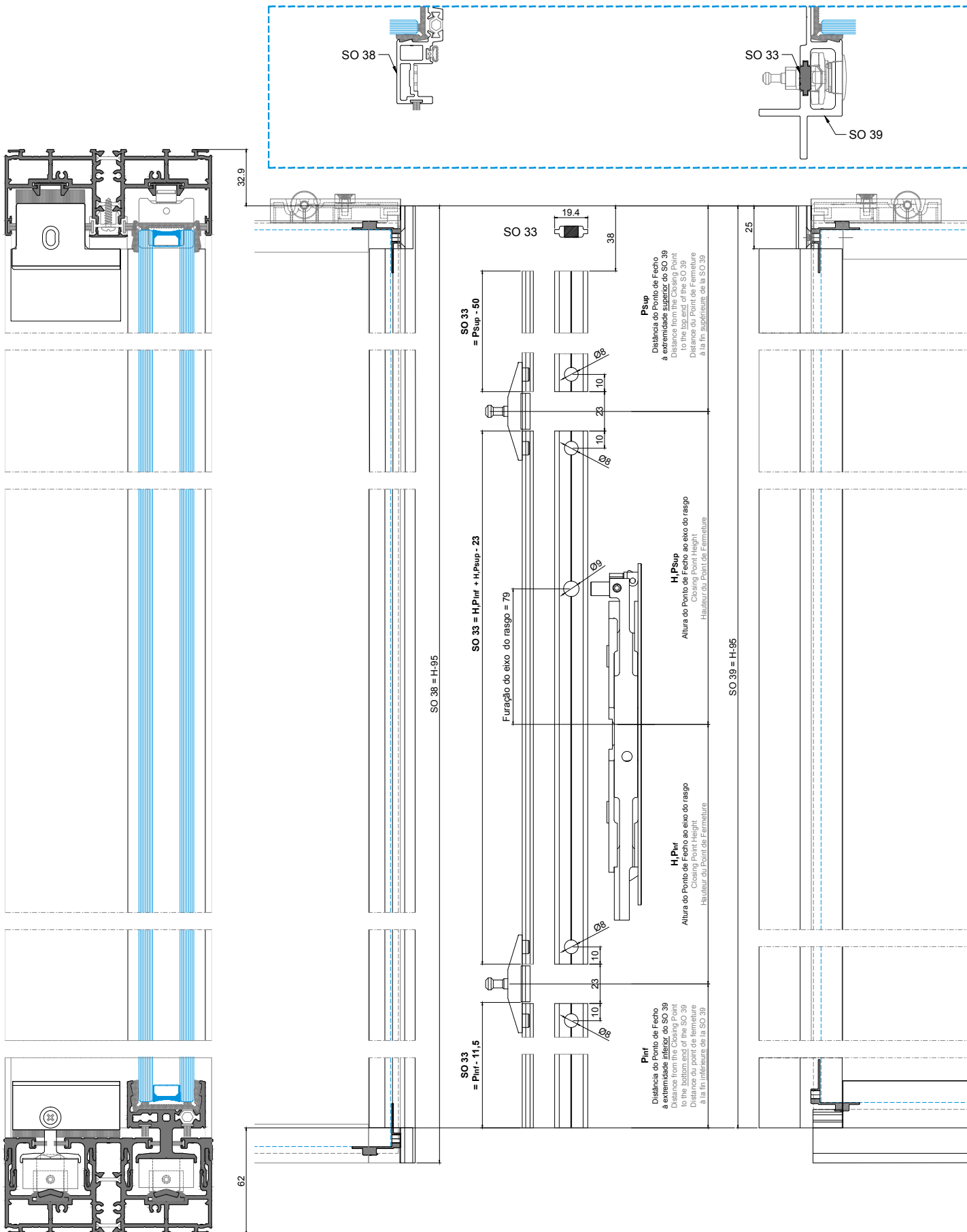

MEDIDA DE CORTE SO 33, SO 38 E SO 39 - SOLEIRA OCULTA OS 18
CUTTING MEASURE SO 33, SO 38 AND SO 39 - CONCEALED SILL OS 18
MESURE DE COUPE SO 33, SO 38 ET SO 39 - SEUIL CACHÉ OS 18

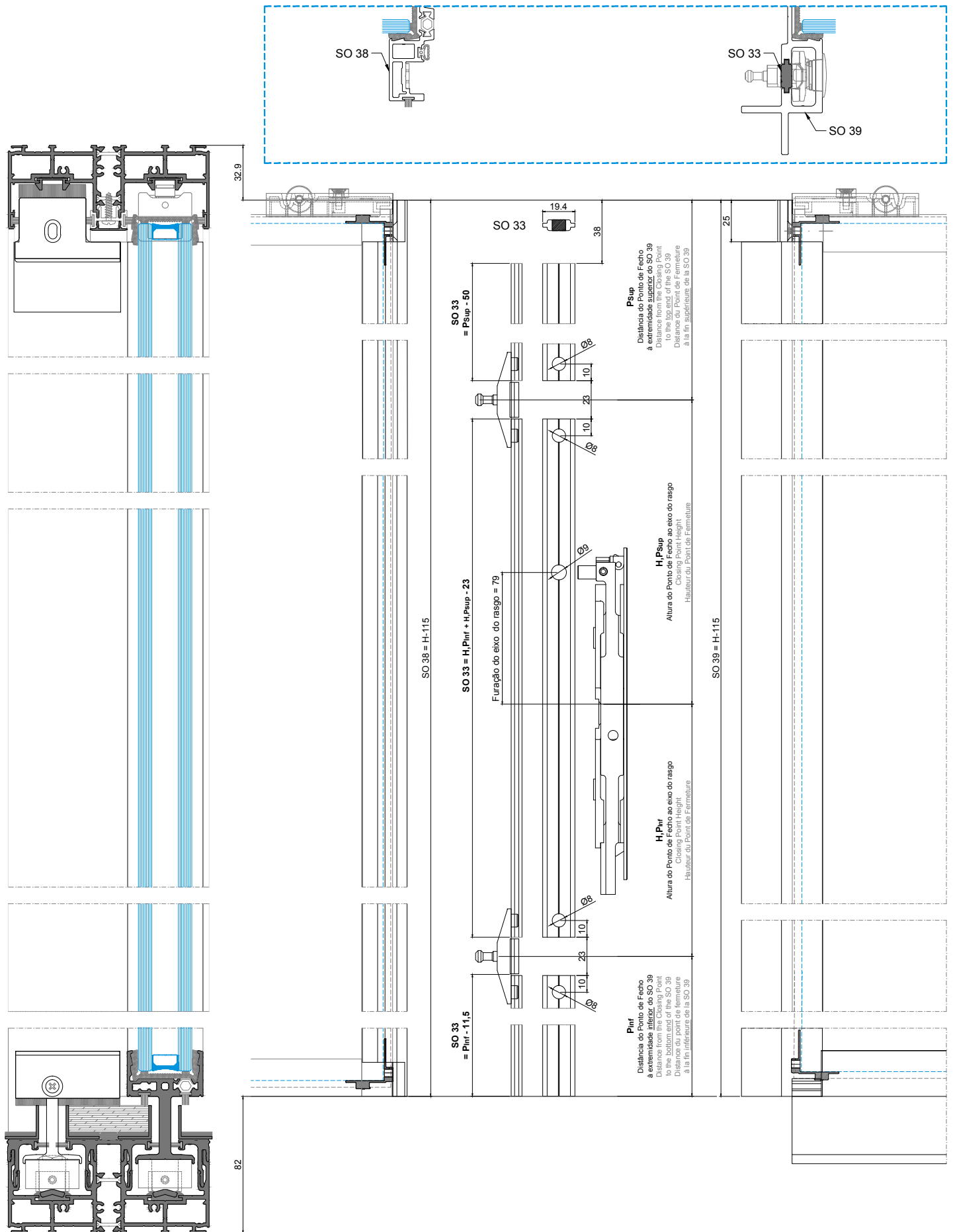

MEDIDAS DE CORTE PERFIS MÓVEIS INFERIORES OS 08 / OS 18 - Janela 2 folhas
CUTTING MEASURES FOR BOTTOM MOBILE PROFILES OS 08 / OS18 - 2 Sashes window
MESURES DE COUPE POUR PROFILÉS MOBILES INFÉRIEURS OS 08 / OS 18 - Fenêtre 2 vantaux

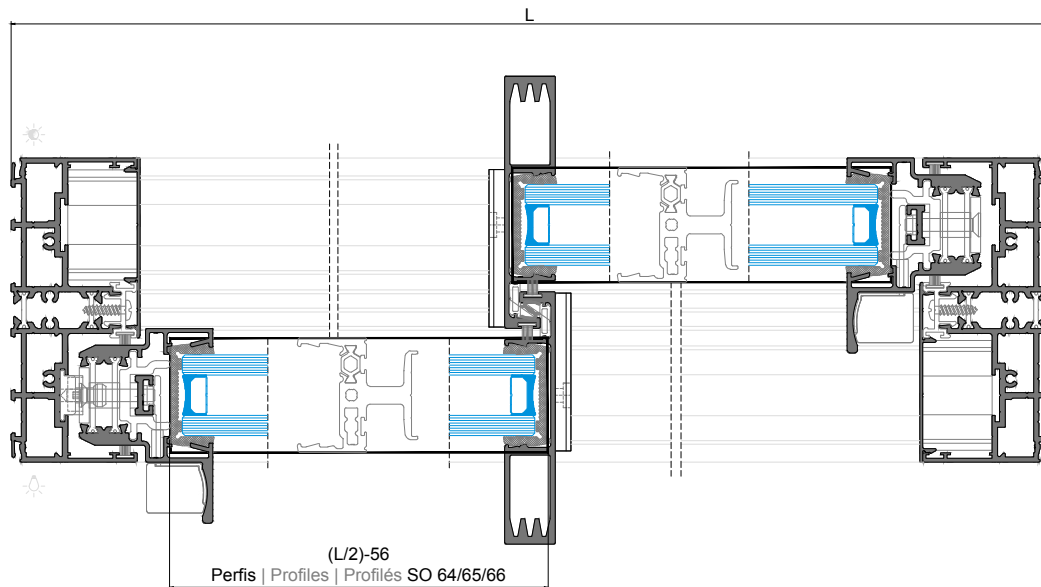

MEDIDAS DE CORTE PERFIS MÓVEIS INFERIORES OS 08 / OS 18 - Janela 3 folhas
CUTTING MEASURES FOR BOTTOM MOBILE PROFILES OS 08 / OS18 - 3 Sashes window
MESURES DE COUPE POUR PROFILÉS MOBILES INFÉRIEURS OS 08 / OS 18 - Fenêtre 3 vantaux

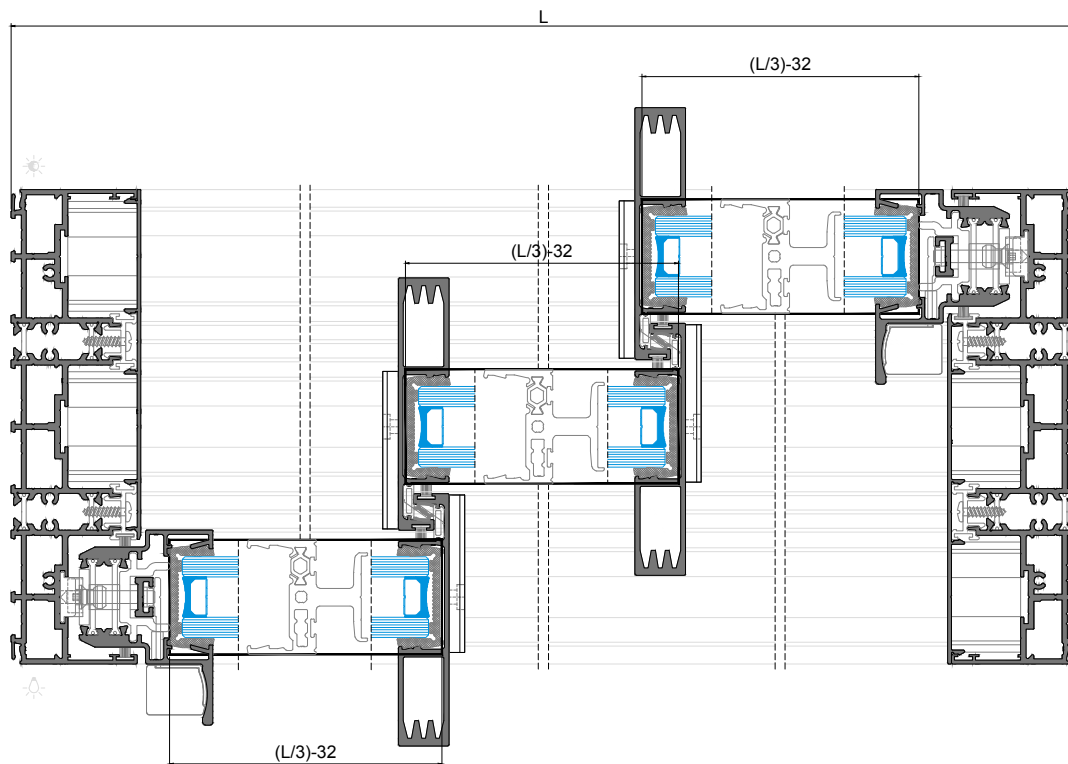

MEDIDAS DE CORTE PERFIS MÓVEIS INFERIORES OS 08 / OS 18 - Janela 2 folhas com 2 fechaduras
CUTTING MEASURES FOR BOTTOM MOBILE PROFILES OS 08 / OS18 - 2 Sashes window with 2 locks
MESURES DE COUPE POUR PROFILÉS MOBILES INFÉRIEURS OS 08 / OS 18 - Fenêtre 2 vantaux avec 2 serrures

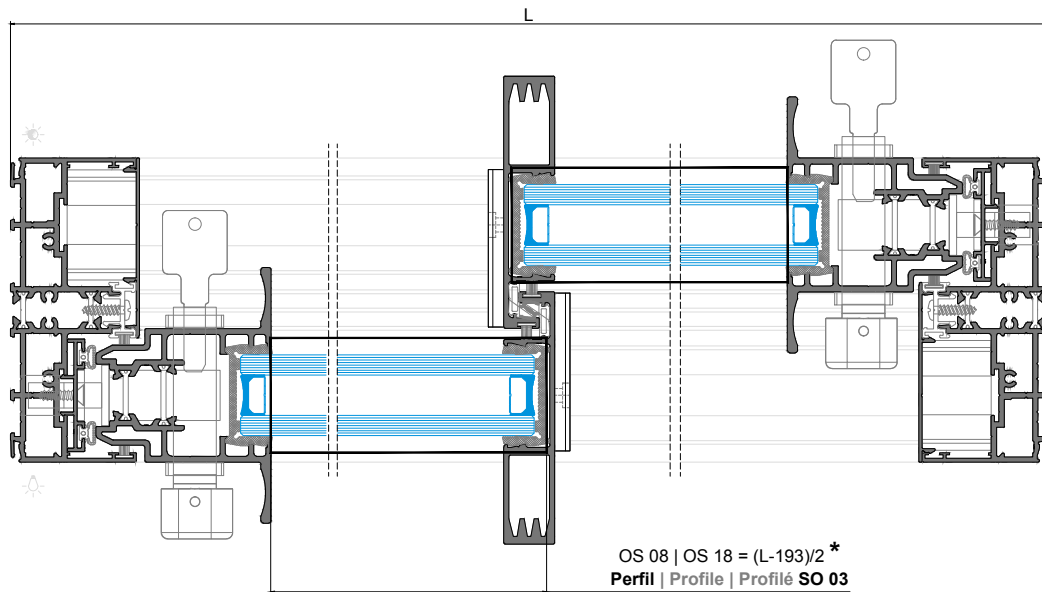

* Com aros centrais ao centro do vão → Vidros com larguras iguais
* With central profiles in the middle of the frame → Glasses with equal widths
* Avec profilés centraux au centre du châssis → Verre de même largeurs

MEDIDAS DE CORTE PERFIS MÓVEIS INFERIORES OS 08 / OS 18 - Janela 3 folhas com 2 fechaduras
CUTTING MEASURES FOR BOTTOM MOBILE PROFILES OS 08 / OS18 - 3 Sashes window with 2 locks
MESURES DE COUPE POUR PROFILÉS MOBILES INFÉRIEURS OS 08 / OS 18 - Fenêtre 3 vantaux avec 2 serrures

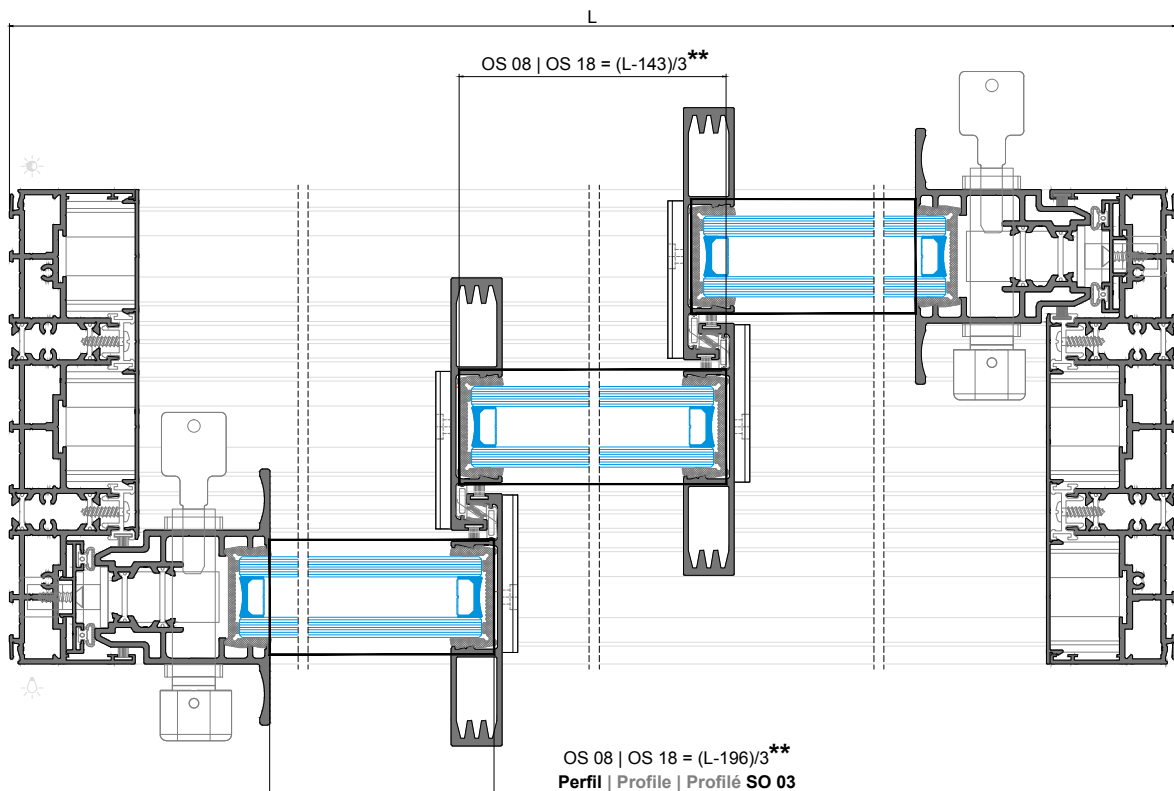

** Vidros com larguras iguais
** Glasses with equal widths
** Verre de même largeurs

MEDIDAS DE CORTE PERFIS MÓVEIS INFERIORES OS 08 / OS 18 - Janela 2 folhas com 1 fechadura e 1 fecho lateral
CUTTING MEASURES FOR BOTTOM MOBILE PROFILES OS 08 / OS 18 - 2 Sashes window with 1 lock and 1 lateral lock
MESURES DE COUPE POUR PROFILÉS MOBILES INFÉRIEURS OS 08 / OS 18 - Fenêtre 2 vantaux avec 1 serrure et 1 surrence latéral

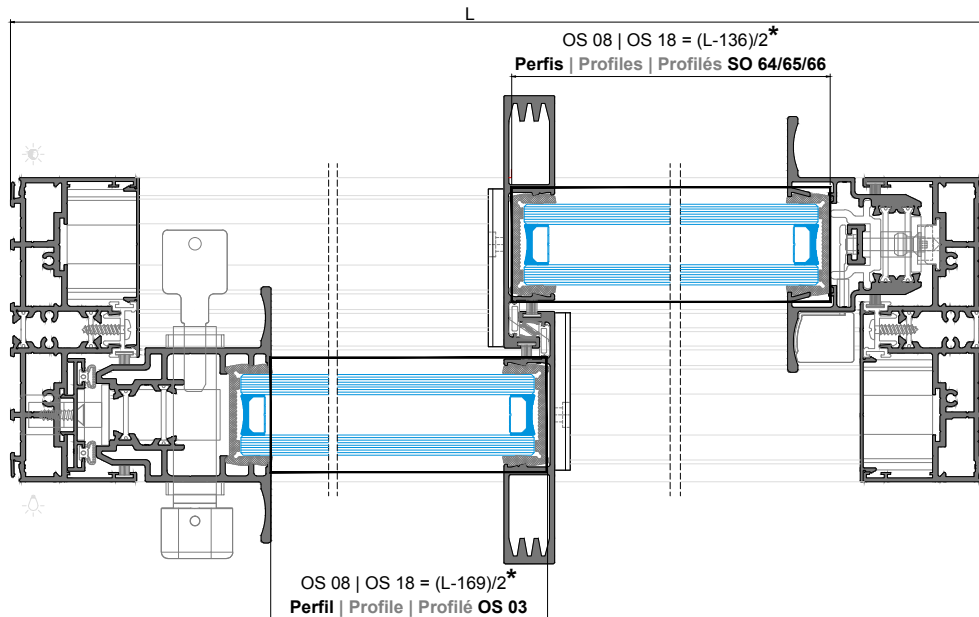

* Com perfis centrais descentrados → Vidros com larguras iguais
* With offset centre profiles → Glasses with equal widths
* Avec profils centraux décentrés → Verre de même largeurs

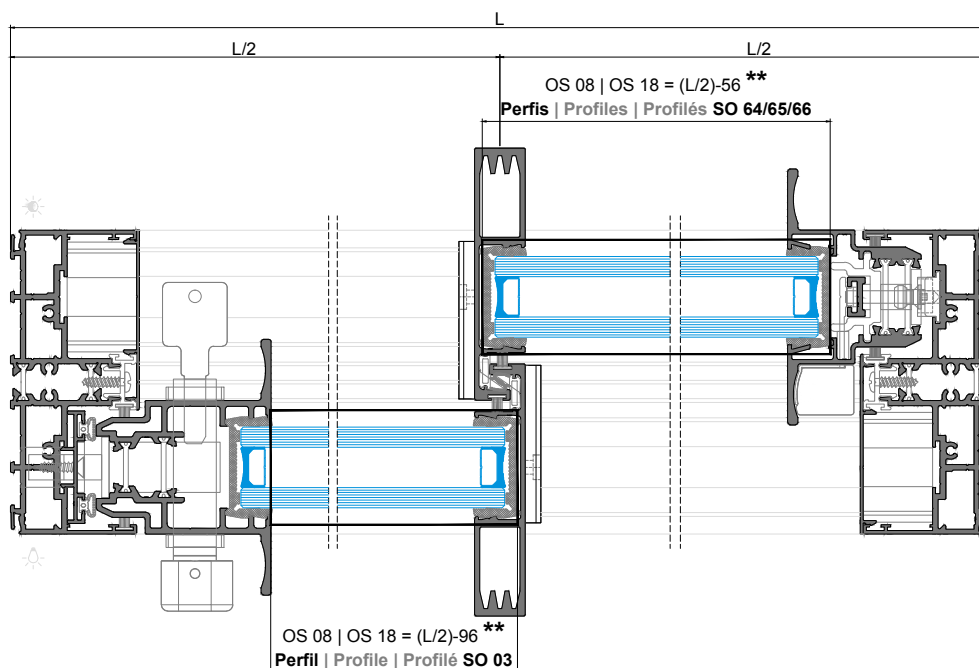

** Com aros centrais ao centro do vão → Vidros com larguras diferentes
** With central profiles in the middle of the frame → Glasses with different widths
** Avec profils centraux au centre du châssis → Verre de différentes largeurs

MEDIDAS DE CORTE PERFIS MÓVEIS INFERIORES OS 08 / OS 18 - Janela 3 folhas com 1 fechadura e 1 fecho lateral
CUTTING MEASURES FOR BOTTOM MOBILE PROFILES OS 08 / OS 18 - 3 Sashes window with 1 lock and 1 lateral lock
MESURES DE COUPE POUR PROFILÉS MOBILES INFÉRIEURS OS 08 / OS 18 - Fenêtre 3 vantaux avec 1 serrure et 1 serrure latéral

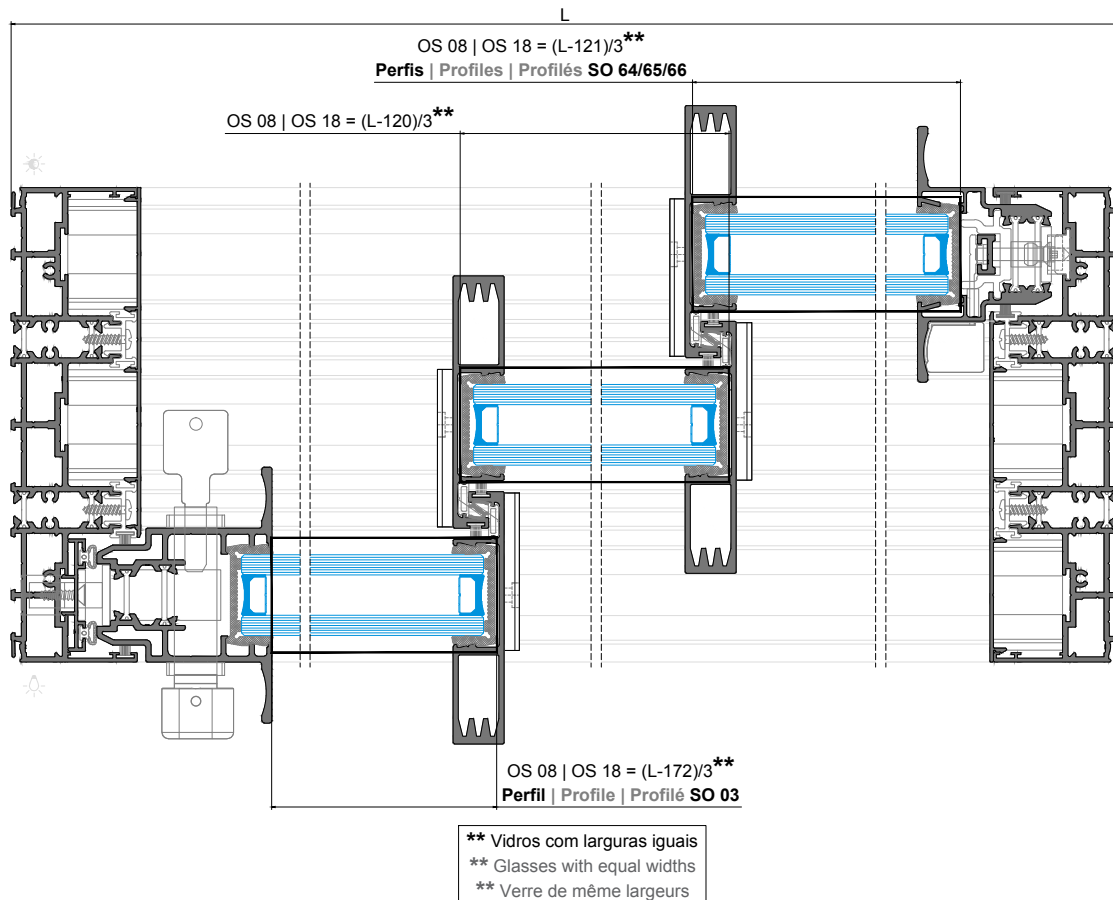

FRESAGENS PARA PERFIS MÓVEIS INFERIORES OS 08 / OS 18

MILLINGS FOR BOTTOM MOBILE PROFILES OS 08 / OS 18

FRAISAGES POUR PROFILÉS MOBILES INFÉRIEURS OS 08 / OS 18

Ligação lateral
Lateral connection
Connexion latérale

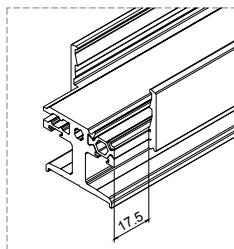

Ligação central
Central connection
Connexion centrale

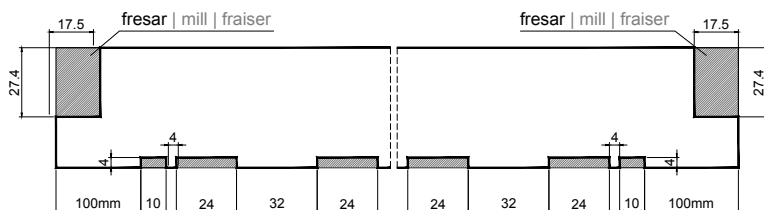
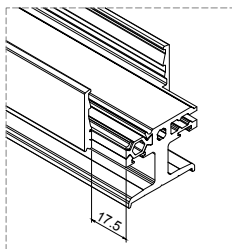

Canal para encaixe de carrinho
Channel to rolling bearing plug
Chenal pour emboîte du rouleau

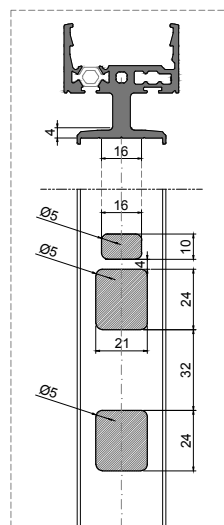

DRENAGENS PARA PERFIS MÓVEIS INFERIORES OS08 / OS18

DRAINAGE FOR BOTTOM MOBILE PROFILES OS08 / OS18

DRAINAGE POUR PROFILÉS MOBILES INFÉRIEURS OS08 / OS18

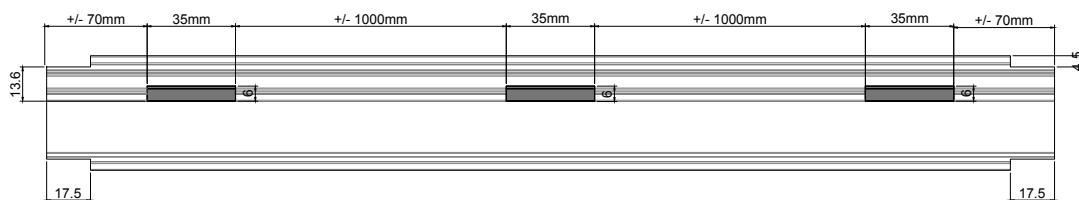

Selar extremidades com silicone

Seal ends with silicone

Sceller l'extrémités avec silicone

Aplicar silicone

Apply silicone

Appliquer silicone

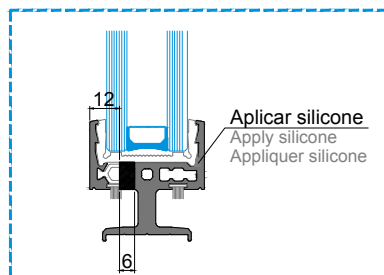

Aplicar silicone
Apply silicone
Appliquer silicone

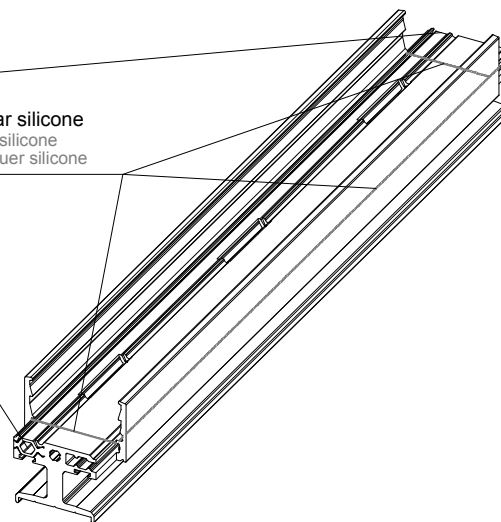

FRESAGENS PARA PERFIS MÓVEIS INFERIORES OS 08 / OS 18

MILLINGS FOR BOTTOM MOBILE PROFILES OS 08 / OS 18

FRAISAGES POUR PROFILÉS MOBILES INFÉRIEURS OS 08 / OS 18

Ligação lateral - Perfil Fechadura

Lateral connection - Lock Profile
Connexion latérale - Profilé pour Serrure

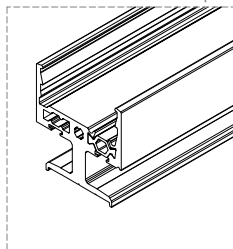

Ligação central

Central connection
Connexion centrale

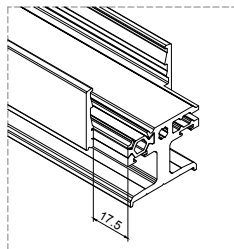

Canal para encaixe de carrinho

Channel to rolling bearing plug
Chenal pour emboîte du rouleau

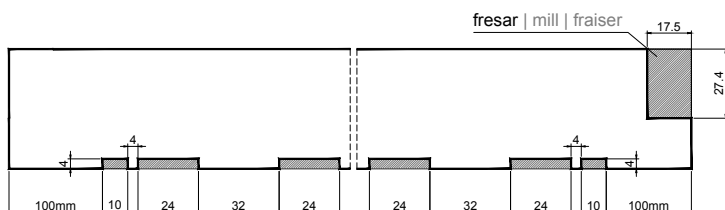
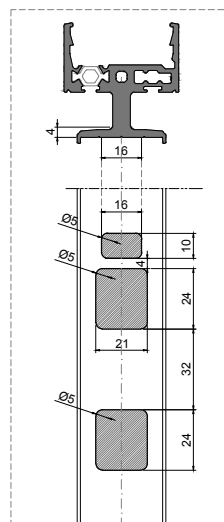

DRENAGENS PARA PERFIS MÓVEIS INFERIORES OS08 / OS18

DRAINAGE FOR BOTTOM MOBILE PROFILES OS08 / OS18

DRAINAGE POUR PROFILÉS MOBILES INFÉRIEURS OS08 / OS18

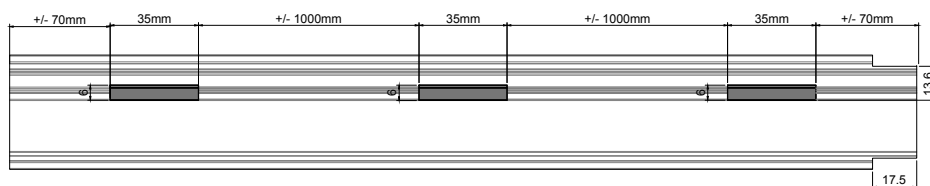

Selar extremidades com silicone

Seal ends with silicone
Sceller l'extrémités avec silicone

Aplicar silicone
Apply silicone
Appliquer silicone

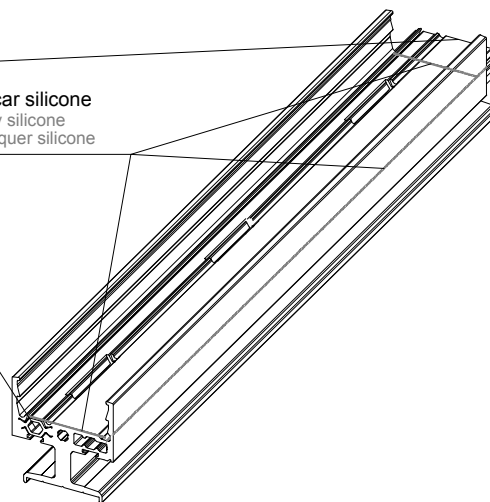
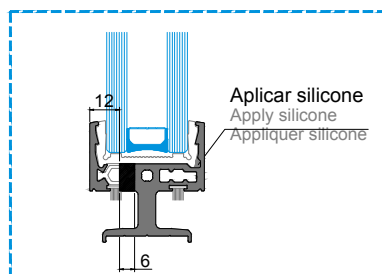

FRESAGENS PARA PERFIL DE MOSQUITEIRA OS 47
MILLINGS FOR MOSQUITO NET PROFILE OS 47
FRAISAGES POUR PROFILÉ MOUSTIQUAIRE OS 47

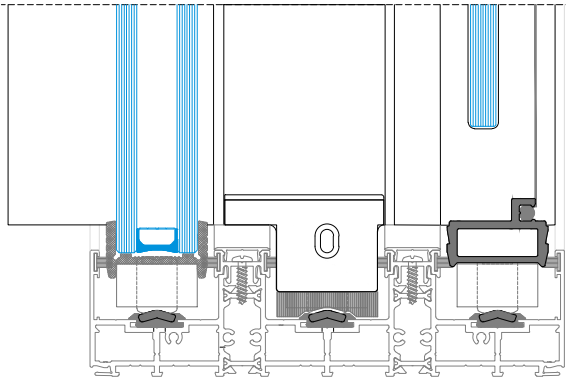

Canal para encaixe de carrinho
Channel to rolling bearing plug
Chenal pour emboîte du rouleau

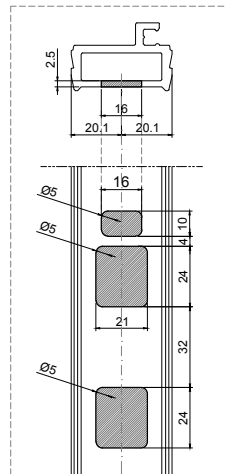

MAQUINAÇÕES CENTRAIS P/ FECHO LATERAL OS N.4 E TESTA - COM VARETA SO 30
LOCK N.4 AND STRICKING PLATE CENTRAL MACHINING - WITH SO 30 ROD PROFILE
USINAGES CENTRAUX POUR SERRURE LATÉRALE N. 4 ET GÂCHE - AVEC TIGE SO 30

SOLEIRA TRADICIONAL | CLASSIC SILL | SEUIL CLASSIQUE

IMPORTANTE | IMPORTANT | IMPORTANT:
No ponto de fecho central é necessário o corte na zona superior da peça devido à proximidade à moldura.
E na vareta de cremone não será necessário a furação superior.
Necessary cut in the wedge part of the piece due to its proximity to the frame in the central lock. And the top drilling is not necessary in the cremone profile.
Coupe nécessaire dans la partie supérieure de la pièce, en raison de la proximité du ressort en la serrure centrale. Et dans la cremone ne sera pas nécessaire la perçage supérieur.
www.os-d.com

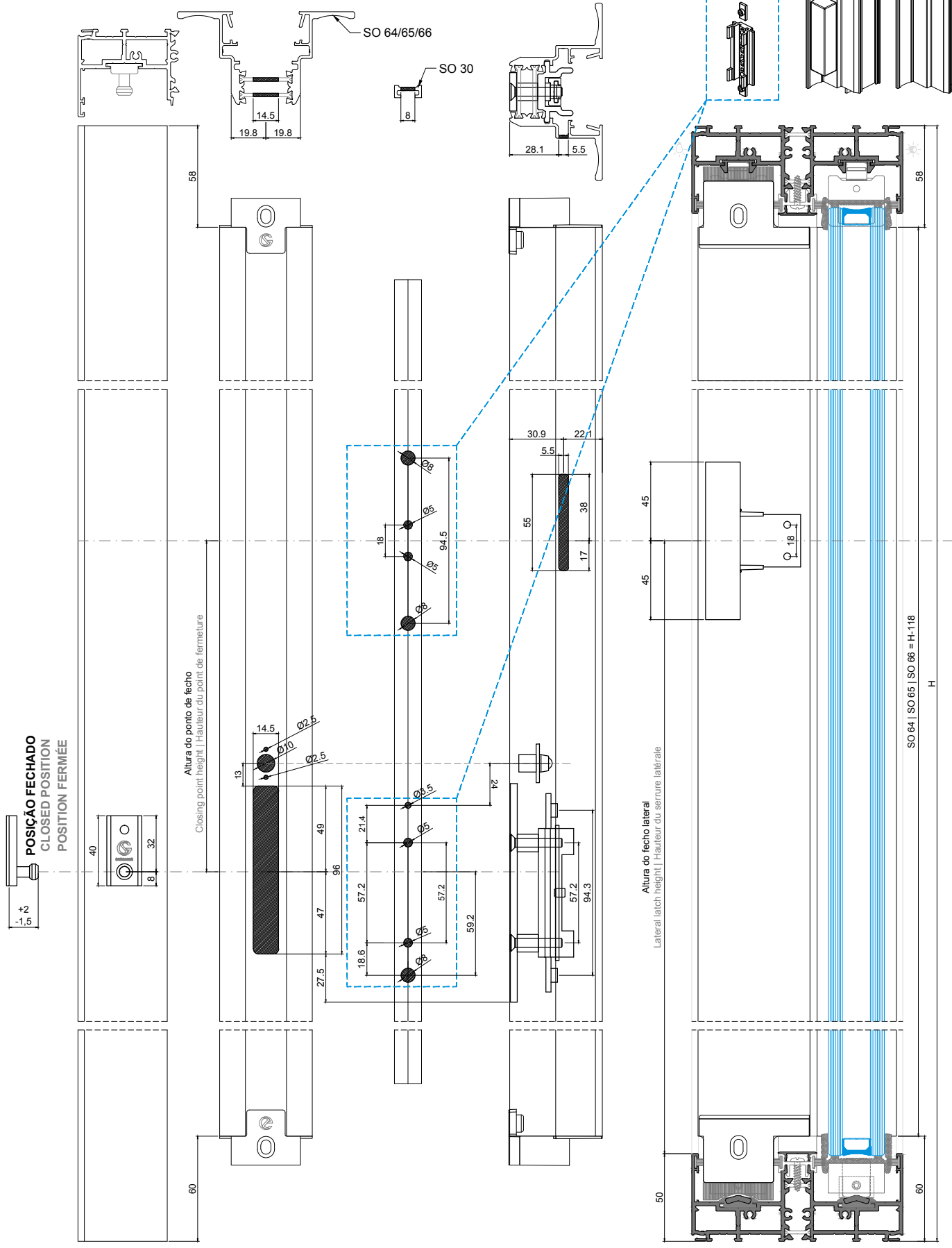
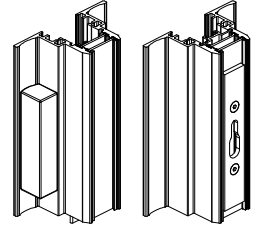

MAQUINAÇÕES CENTRAIS P/ FECHO LATERAL OS N.4 E TESTA - COM VARETA SO 30
LOCK N.4 AND STRICKING PLATE CENTRAL MACHINING - WITH SO 30 ROD PROFILE

USINAGES CENTRAUX POUR SERRURE LATÉRALE N. 4 ET GÂCHE - AVEC TIGE SO 30

SOLEIRA OCULTA - PERFIL OS 18
CONCEALED SILL - PROFILE OS 18
SEUIL CACHÉ - PROFILÉ OS 18

IMPORTANTE | IMPORTANT | IMPORTANT:
No ponto de fecho central é necessário o corte na zona superior da peça devido à proximidade à moldura.
E na vareta de cremone não será necessário a furação superior.
Necessary cut in the wedge part of the piece due to the proximity to the frame in the central lock. And the top drilling is not necessary in the cremone profile.
Coupe nécessaire dans la partie supérieure de la pièce, en raison de la proximité du ressort en la serrure centrale. Et dans la cremone ne sera pas nécessaire la perçage supérieur.
www.osd.pt

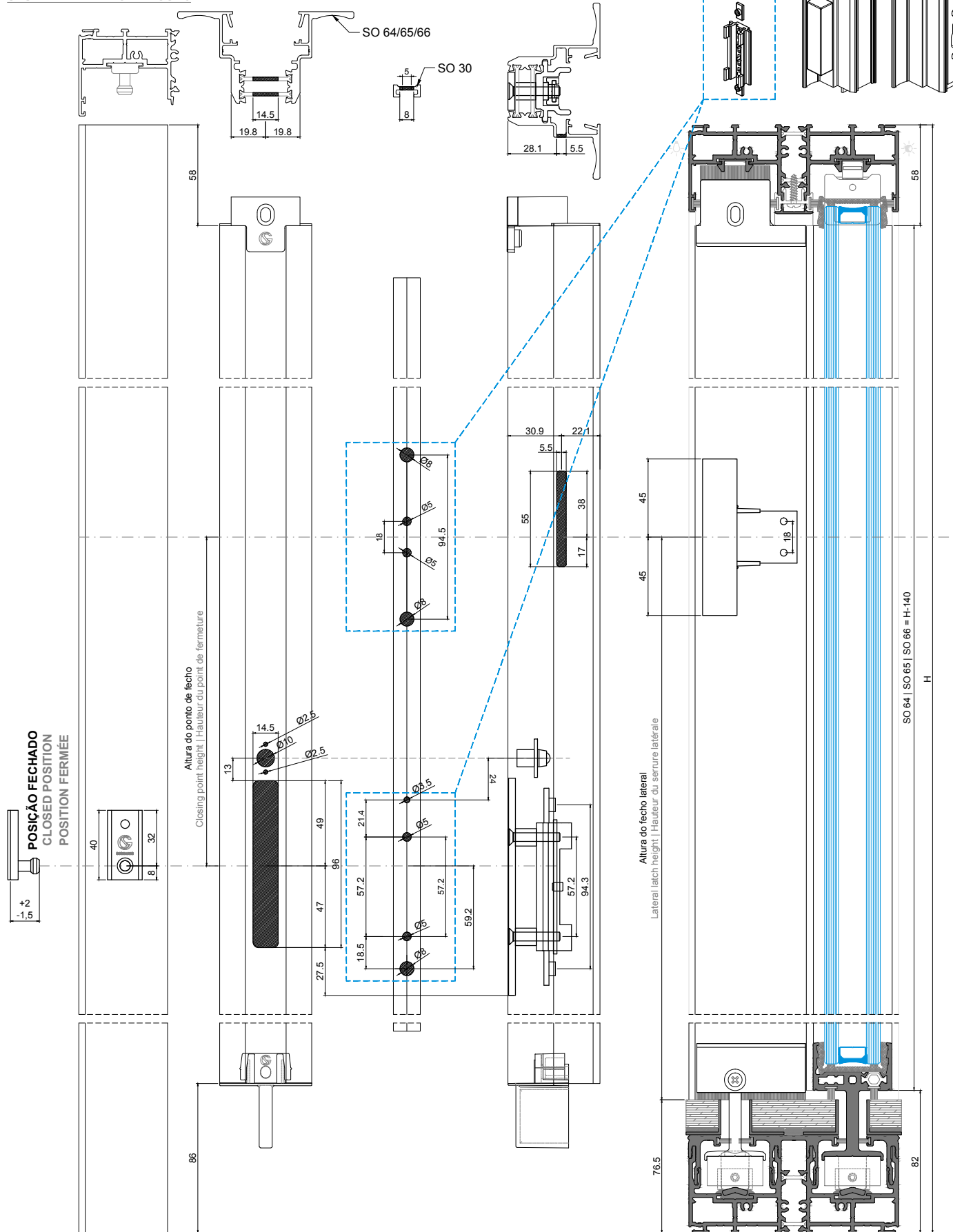
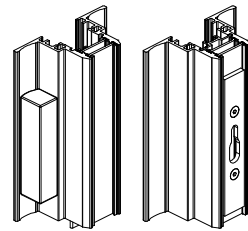

MAQUINAÇÕES PARA TESTAS INFERIOR E SUPERIOR OS - COM VARETA SO 30
MACHINING FOR LOWER AND UPPER STRIKING PLATES - WITH SO 30 ROD PROFILE
USINAGE DES GÂCHES INFÉRIEUR ET SUPÉRIEUR - AVEC TIGE SO 30

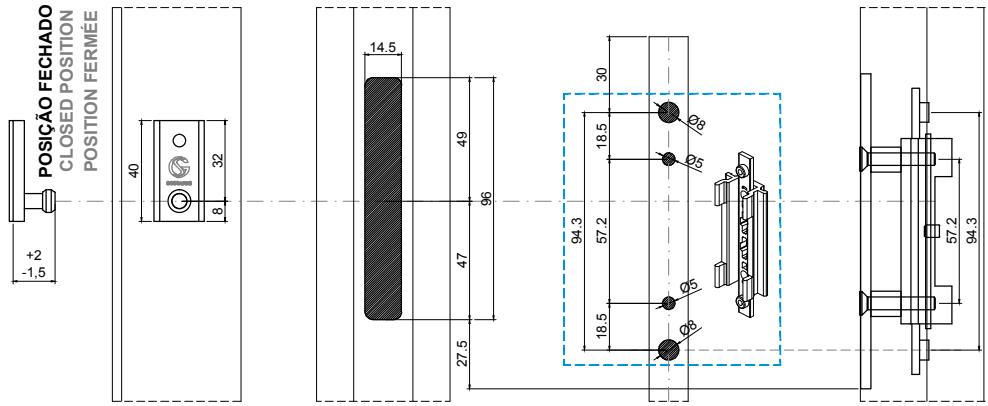
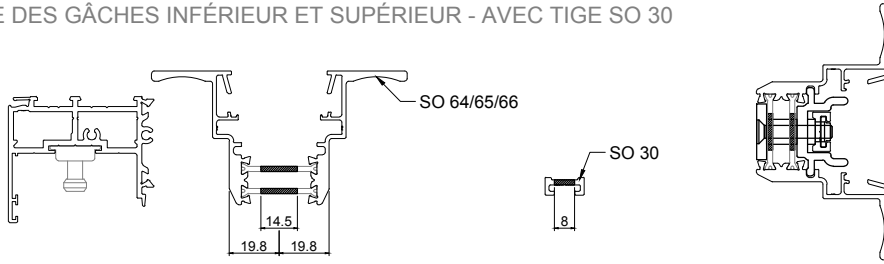

MAQUINAÇÕES P/ PARA PONTO DE FECHO SUPERIOR
SUPERIOR LOCK MACHINING
USINAGES POUR SERRURE SUPERIEUR

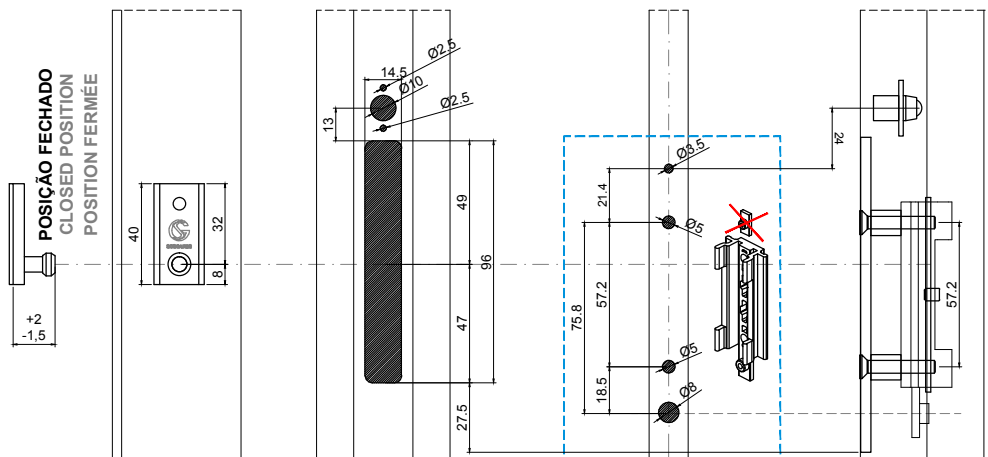
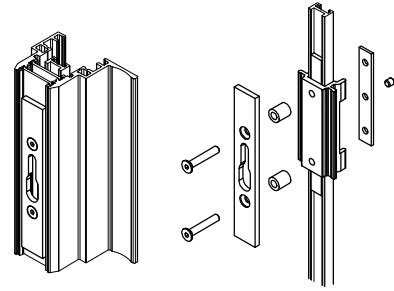

MAQUINAÇÕES P/ PARA PONTO DE FECHO CENTRAL
CENTRAL LOCK MACHINING
USINAGES POUR SERRURE CENTRAL

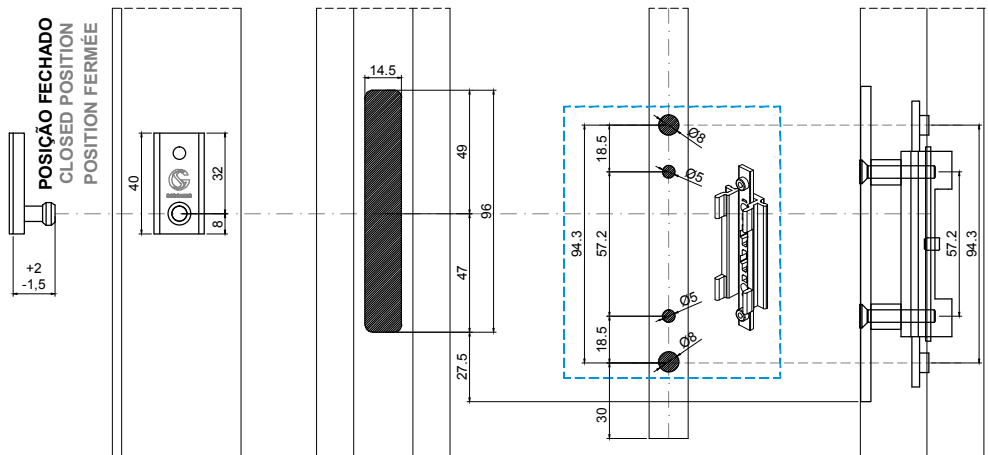
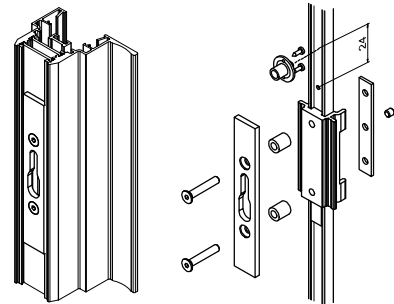

MAQUINAÇÕES P/ PARA PONTO DE FECHO INFERIOR
INFERIOR LOCK MACHINING
USINAGES POUR SERRURE INFÉRIEUR

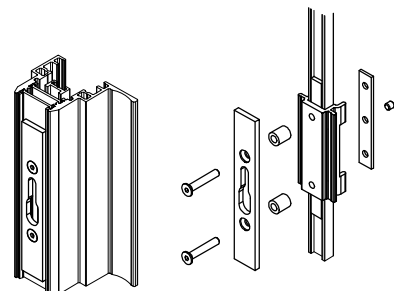
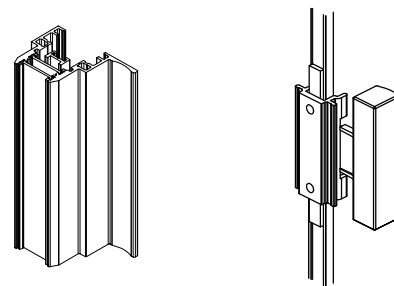

MAQUINAÇÕES PARA KIT FECHOS MAGNÉTICOS
MACHINING FOR MAGNETIC LOCK KITS
USINAGE POUR KITS DE SERRURE MAGNÉTIQUE

EM PERFIL OMBREIRA 1-RAIL | IN 1-RAIL JAMB PROFILE | EN PROFILÉ DE JAMBAGE À 1-RAIL

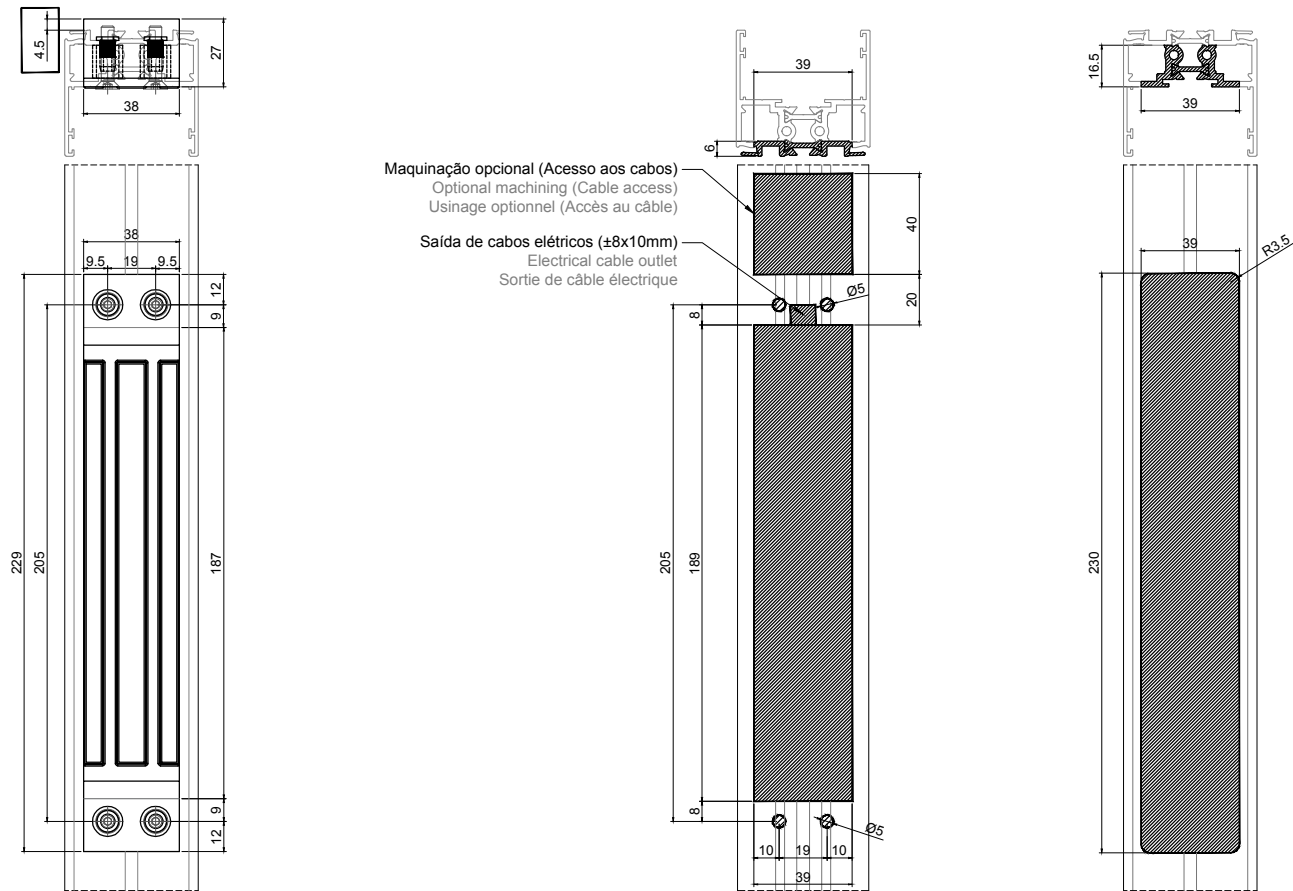

EM PERFIL OMBREIRA 2-RAIL OU 3-RAIL | IN 2-RAIL OR 3-RAIL JAMB PROFILE | EN PROFILÉ DE JAMBAGE À 2-RAIL OU 3-RAIL

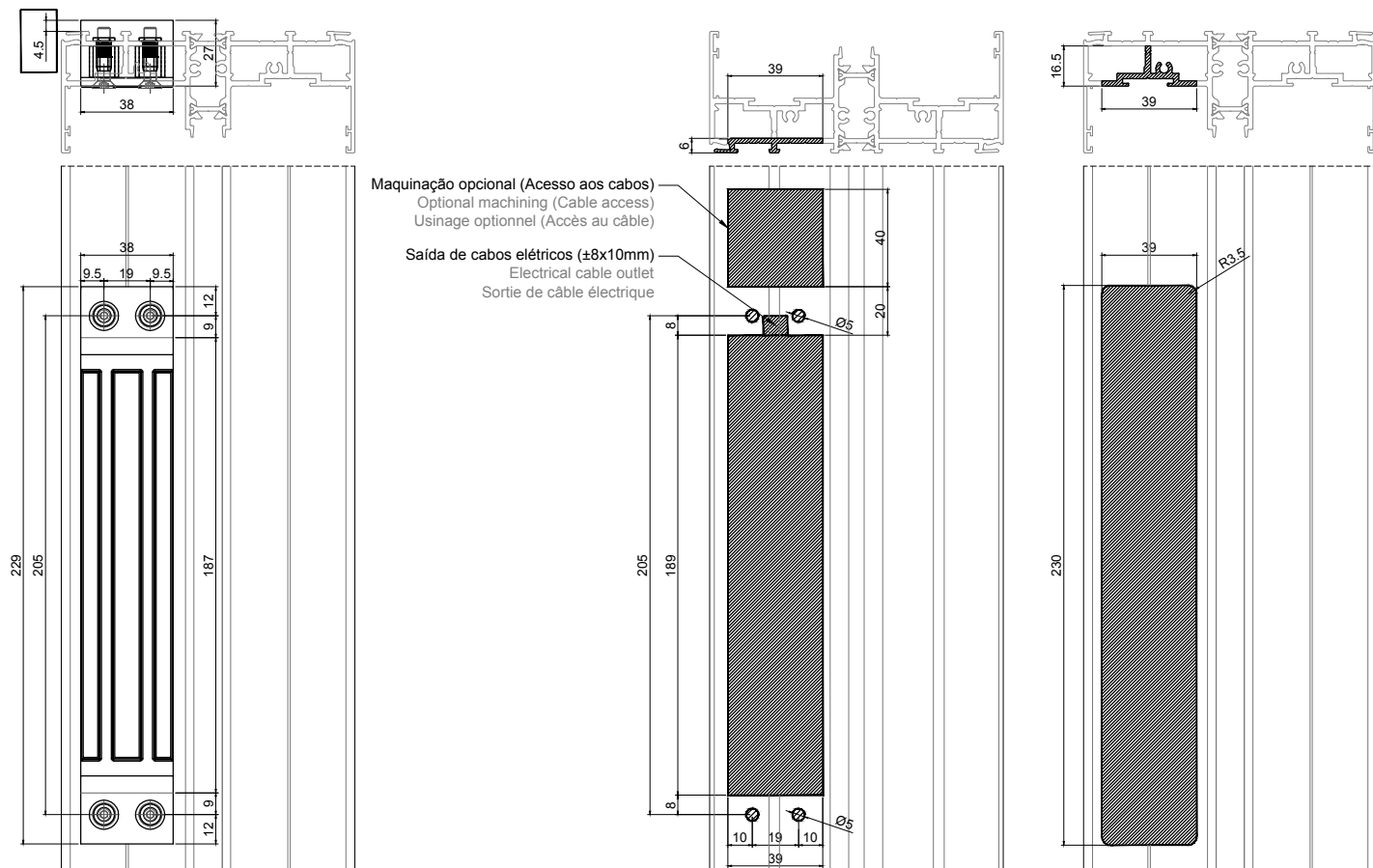



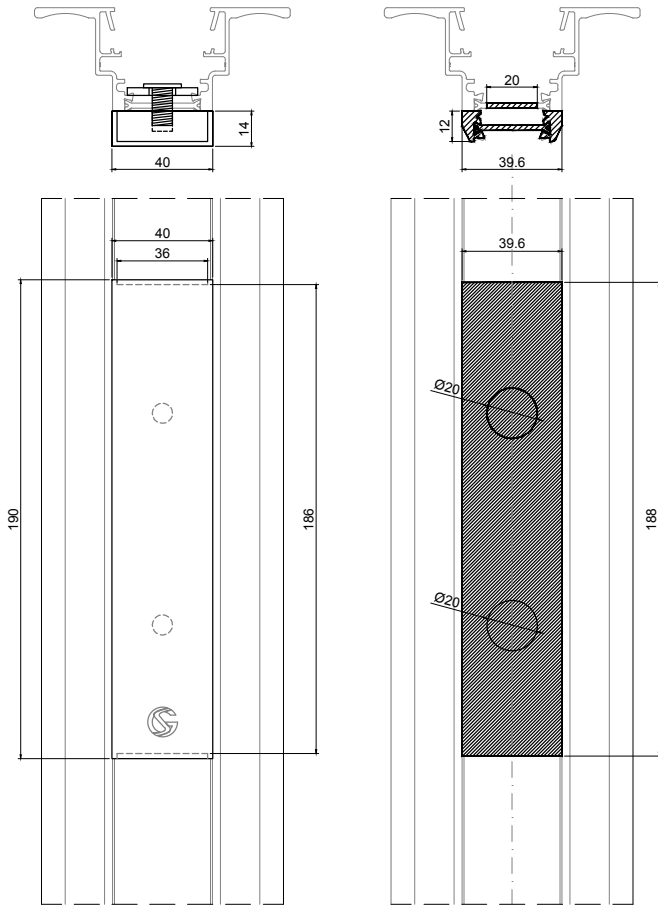
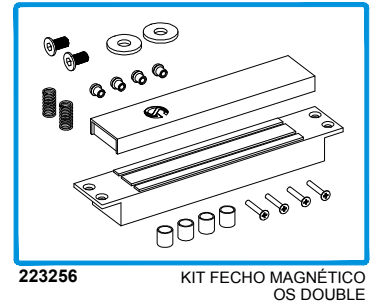

MAQUINAÇÕES PARA KIT FECHOS MAGNÉTICOS
MACHINING FOR MAGNETIC LOCK KITS
USINAGE POUR KITS DE SERRURE MAGNÉTIQUE

EM PERFIL MÓVEL LATERAL
IN LATERAL MOBILE PROFILE | EN PROFILÉ OUVRANT LATÉRAL



Relação Parafuso/Mola
Screw/spring ratio | Rapport entre la vis et le ressort

Conjunto a utilizar Kit to be used Ensemble à utiliser	Parafuso 27 mm Screw Vis	Parafuso 16,5 mm Screw Vis
		
Mola tipo 1 Spring type 1 Type de ressort 1 	Não é necessário qualquer ajuste No adjustment necessary Pas d'ajustement nécessaire	Cortar mola com 25 mm Cut spring with 25 mm Couper le ressort à 25 mm
Mola tipo 2 Spring type 2 Type de ressort 2 	Cortar parafuso com 16,5mm e utilizar 3 molas Cut the screw to 16.5mm and use 3 springs Couper la vis à 16,5 mm et utiliser 3 ressorts	Utilizar 3 molas Use 3 springs Utiliser 3 ressorts

INSTRUÇÕES DE MONTAGEM
ASSEMBLY INSTRUCTIONS | INSTRUCTIONS D'ASSEMBLAGE

• **Fechadura Magnética | Magnetic lock | Serrure magnétique**

- Depois de mecanizar o perfil aro fixo, aplicar os rebites nos furos da parte posterior do perfil.
After machining the fixed frame profile, apply the rivets to the holes in the back of the profile. | Après usinage du profilé du cadre dormant, poser les rivets dans les trous situés à l'arrière du profilé.
- Colocar os tubos no interior do perfil de forma a que os rebites fiquem no seu interior.
Place the tubes inside the profile so that the rivets are placed inside. | Placer les tubes à l'intérieur du profilé de manière à ce que les rivets soient à l'intérieur.
- Pousar a fechadura em cima dos tubos, apontando os parafusos pelo interior dos tubos, de forma a aparafusar diretamente nos rebites.
Place the lock on top of the tubes, pointing the screws along the inside of the tubes so that they screw directly into the rivets. | Placez la serrure sur les tubes, en orientant les vis le long de l'intérieur des tubes de manière à ce qu'elles se vissent directement dans les rivets.

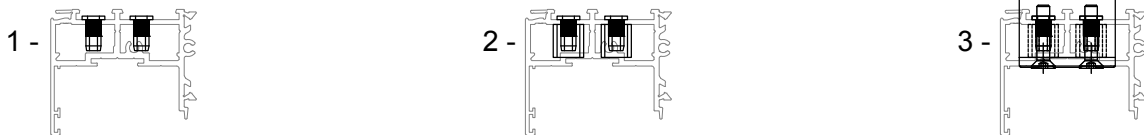

• **Testa Magnética | Magnetic plate | Gâche magnétique**

- Depois de efetuada a maquinação do perfil móvel, posicionar a testa na zona frontal do perfil.
Once the mobile profile has been machined, place the plate at the front of the profile. | Une fois le profilé ouvrant usiné, placez le gâche à l'avant du profilé.
- Colocar as molas junto aos furos da poliamida posterior do perfil.
Place the springs next to the holes in the back polyamide of the profile. | Placer les ressorts à côté des trous dans le polyamide arrière du profilé.
- Passar os parafusos através das anilhas, das molas e das poliamidas, aparafusando à testa até ao final da rosca.
Pass the screws through the washers, springs and polyamides, screwing into the plate until the end of the thread. | Passer les vis à travers les rondelles, les ressorts et les polyamides, en les vissant à la gâche jusqu'à la fin du filetage.

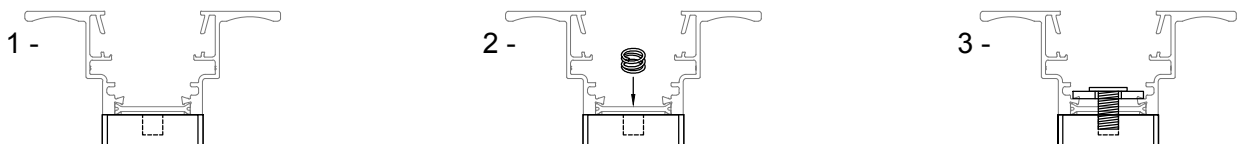

APLICAÇÃO DOS KIT FECHOS MAGNÉTICOS
MAGNETIC LOCK KITS APPLICATION
APPLICATION DES KITS DE SERRURE MAGNÉTIQUE

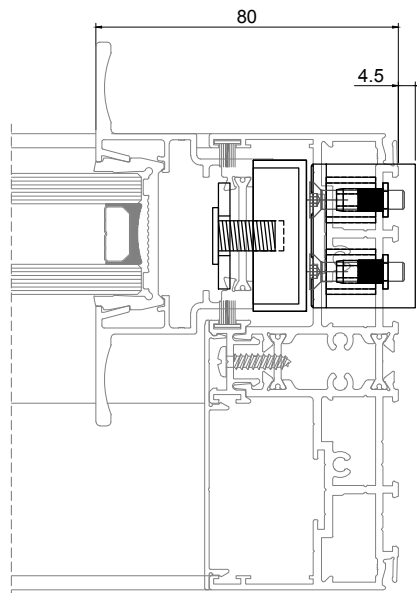
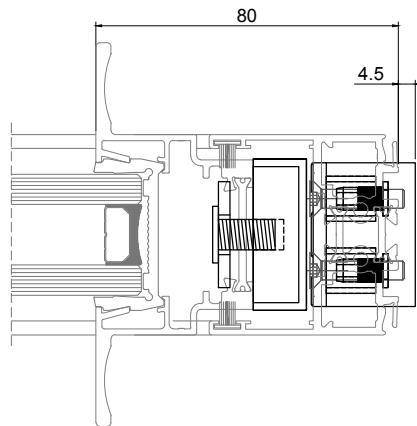



Portet House | Moraira | Dalia Alba Arq. | Fotografia Diego Opazo

VII

MONTAGENS
ASSEMBLIES
ASSAMBLAGES

Montagem de perfis
Profiles assembly
Assemblage des profilés

VII . 1

Montagem de ferragens e acessórios
Hardware and accessories assembly
Assemblage des serrures et accessoires

VII . 2

MONTAGEM DE AROS FIXOS - 1 RAIL

FIXED FRAMES ASSEMBLY - 1 RAIL | ASSEMBLAGE DES DORMANTS - 1 RAIL

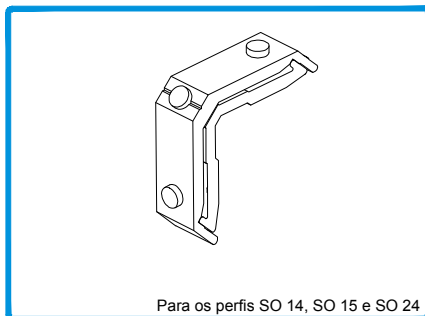

Para os perfis SO 14, SO 15 e SO 24

205173

ESQUADRO 18-1310-C

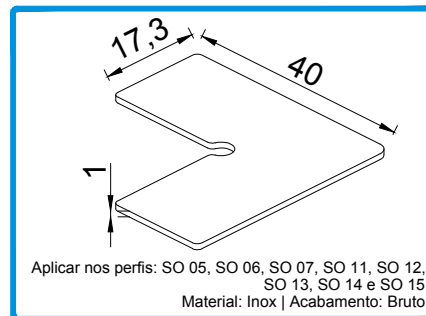

Aplicar nos perfis: SO 05, SO 06, SO 07, SO 11, SO 12, SO 13, SO 14 e SO 15

Material: Inox | Acabamento: Bruto

213018

CANTO DE ALINHAMENTO OS N.º2

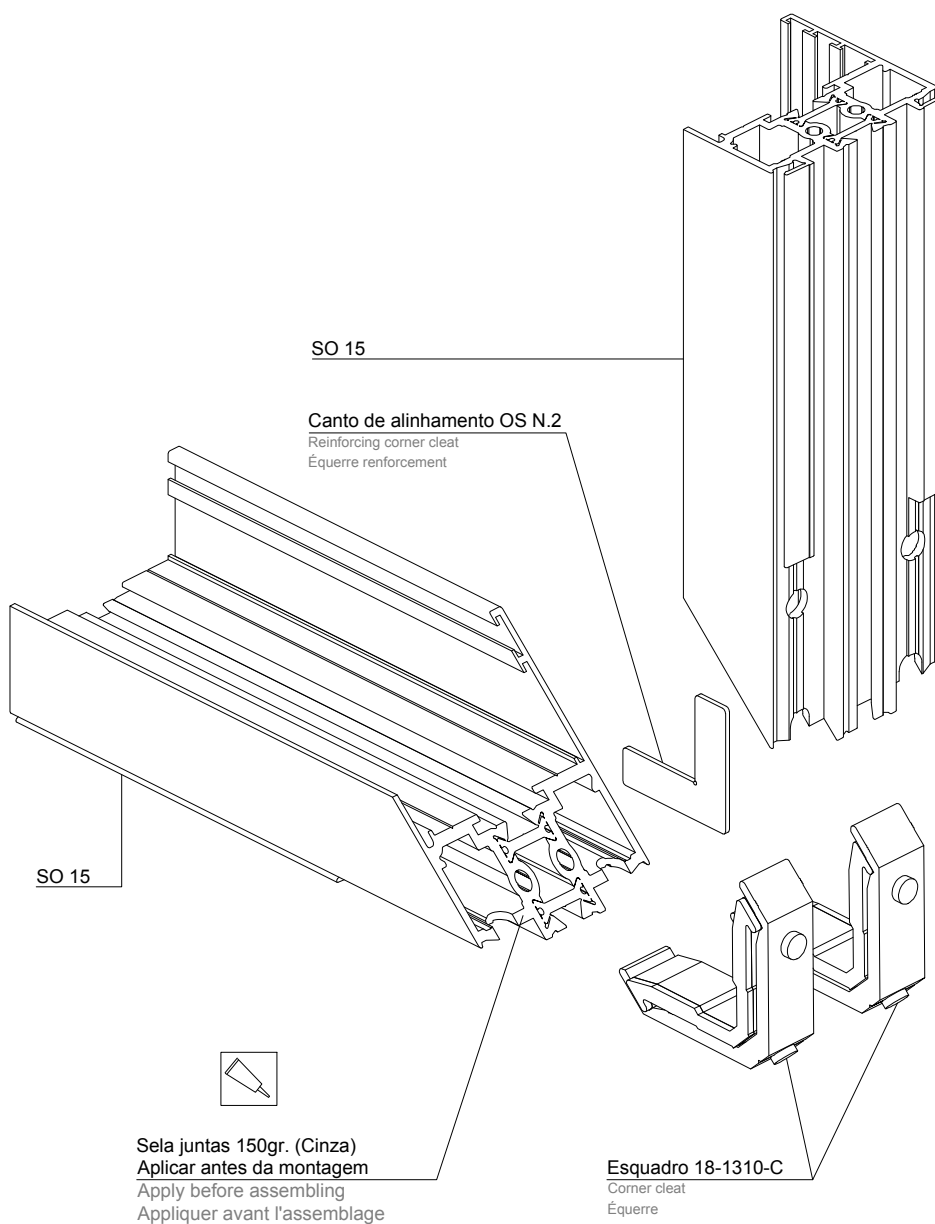

MONTAGEM DE AROS FIXOS - 1 RAIL

FIXED FRAMES ASSEMBLY - 1 RAIL | ASSEMBLAGE DES DORMANTS - 1 RAIL

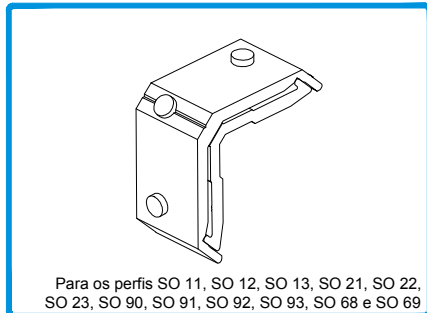

Para os perfis SO 11, SO 12, SO 13, SO 21, SO 22, SO 23, SO 90, SO 91, SO 92, SO 93, SO 68 e SO 69
205172 ESQUADRO 18-2210-D

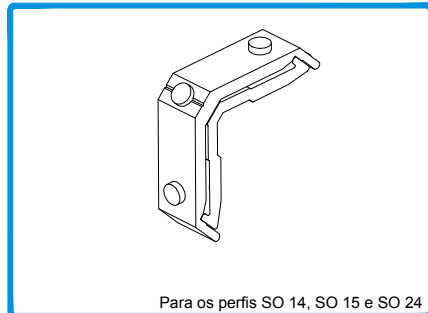

Para os perfis SO 14, SO 15 e SO 24
205173 ESQUADRO 18-1310-C

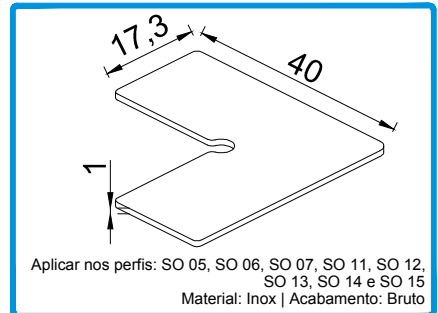

Aplicar nos perfis: SO 05, SO 06, SO 07, SO 11, SO 12, SO 13, SO 14 e SO 15
Material: Inox | Acabamento: Bruto
213018 CANTO DE ALINHAMENTO OS Nº2

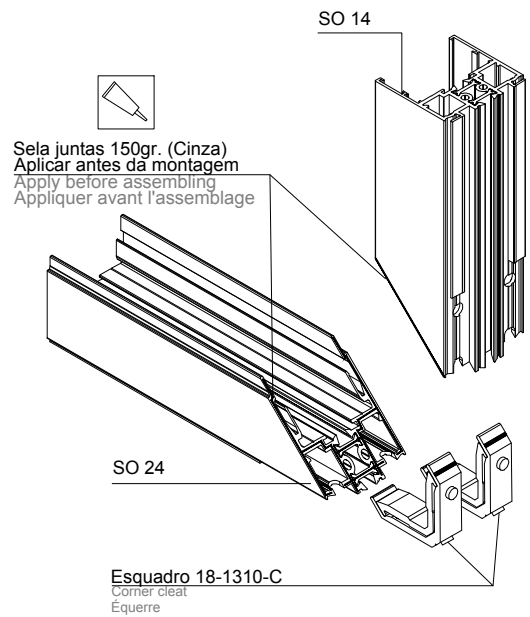
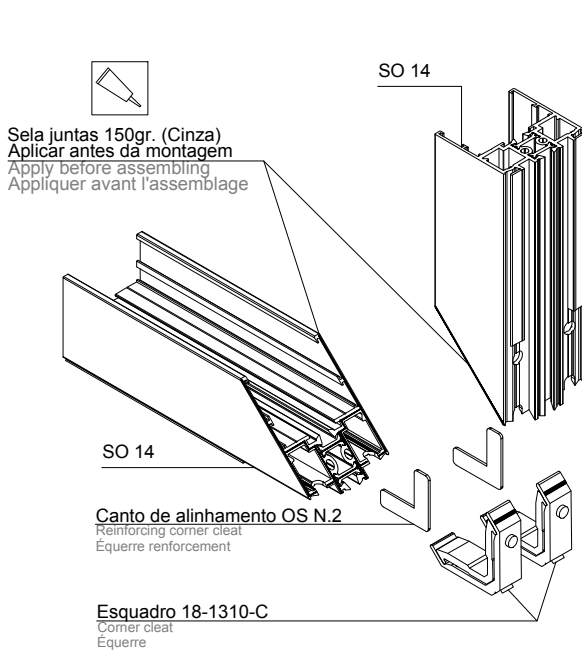

MONTAGEM DE AROS FIXOS - 2 RAILS

FIXED FRAMES ASSEMBLY - 2 RAILS | ASSEMBLAGE DES DORMANTS - 2 RAILS

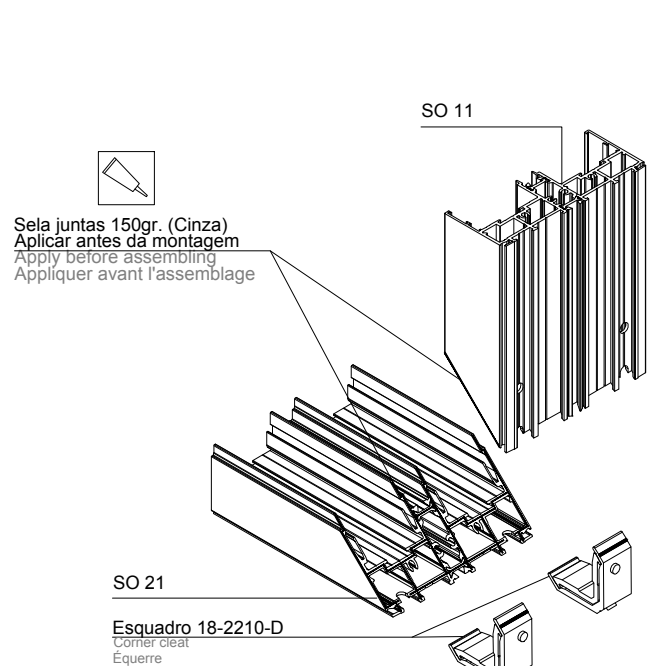
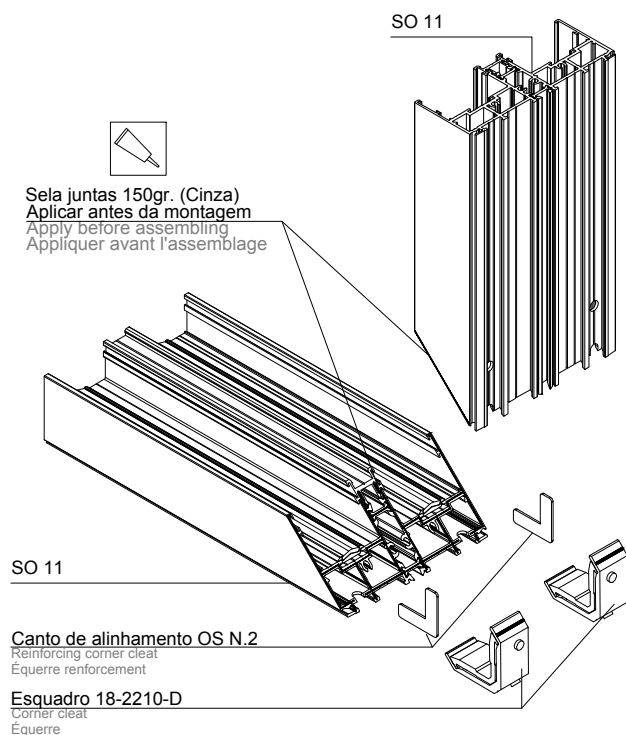

MONTAGEM DE AROS FIXOS - 3 RAILS

FIXED FRAMES ASSEMBLY - 3 RAILS | ASSEMBLAGE DES DORMANTS - 3 RAILS

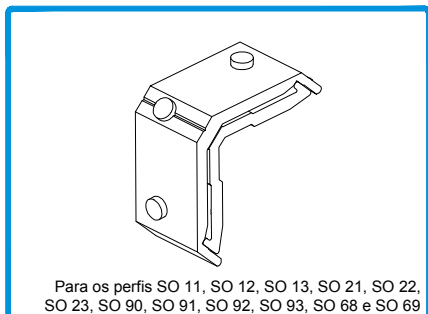

Para os perfis SO 11, SO 12, SO 13, SO 21, SO 22,
SO 23, SO 90, SO 91, SO 92, SO 93, SO 68 e SO 69

205172

ESQUADRO 18-2210-D

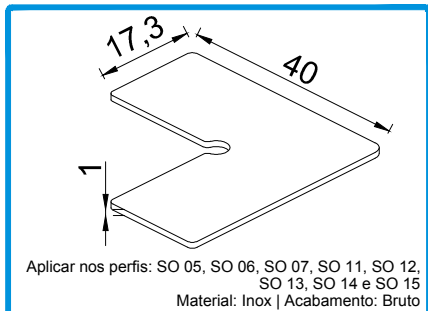

Aplicar nos perfis: SO 05, SO 06, SO 07, SO 11, SO 12,
SO 13, SO 14 e SO 15
Material: Inox | Acabamento: Bruto

213018

CANTO DE ALINHAMENTO OS Nº2

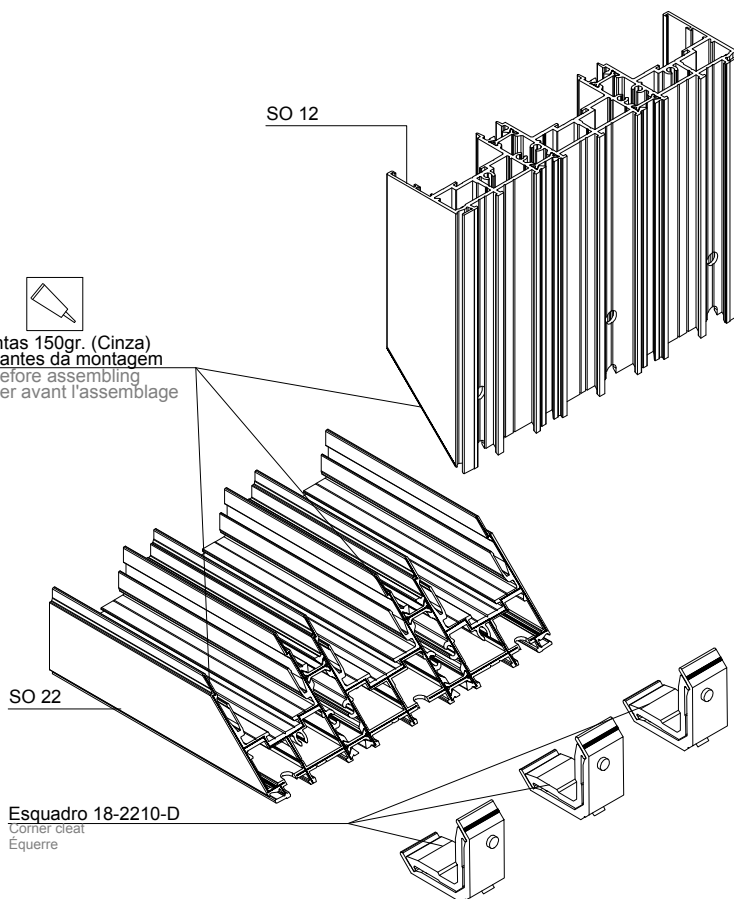
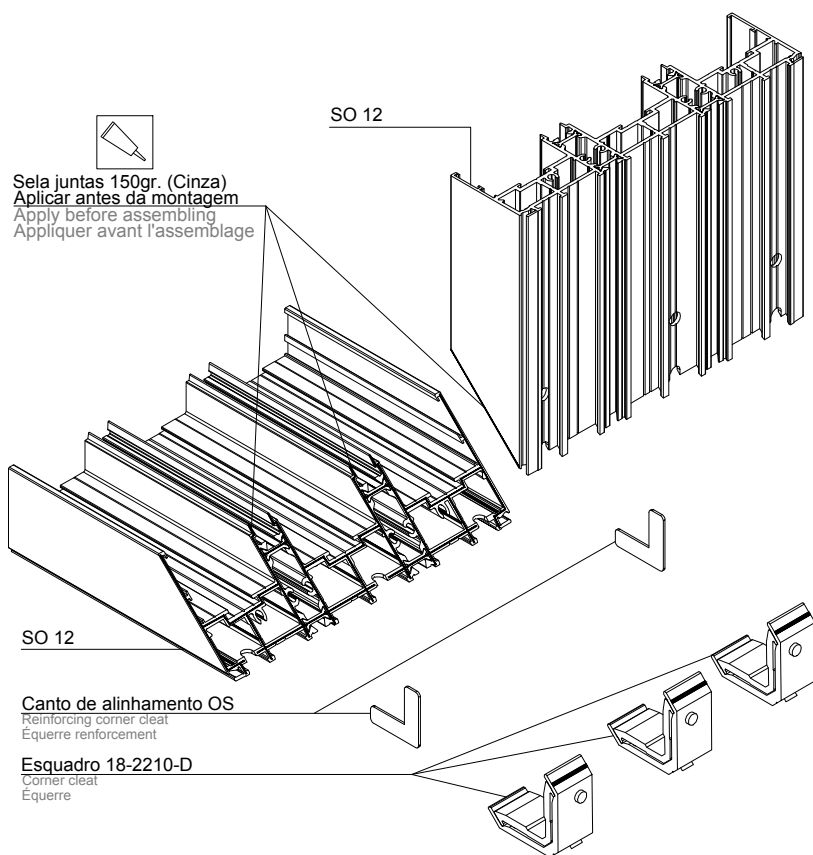

MONTAGEM DE AROS FIXOS - 4 RAILS

FIXED FRAMES ASSEMBLY - 4 RAILS | ASSEMBLAGE DES DORMANTS - 4 RAILS

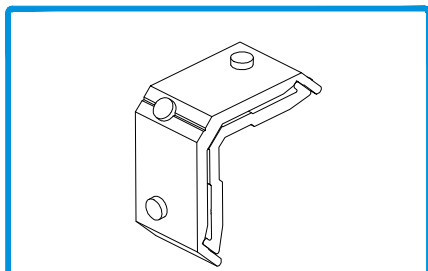

Para os perfis SO 11, SO 12, SO 13, SO 21, SO 22,
SO 23, SO 90, SO 91, SO 92, SO 93, SO 68 e SO 69

205172

ESQUADRO 18-2210-D

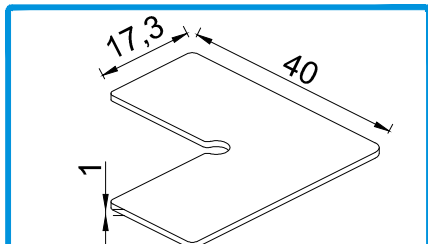

Aplicar nos perfis: SO 05, SO 06, SO 07, SO 11, SO 12,
SO 13, SO 14 e SO 15
Material: Inox | Acabamento: Bruto

213018

CANTO DE ALINHAMENTO OS Nº2

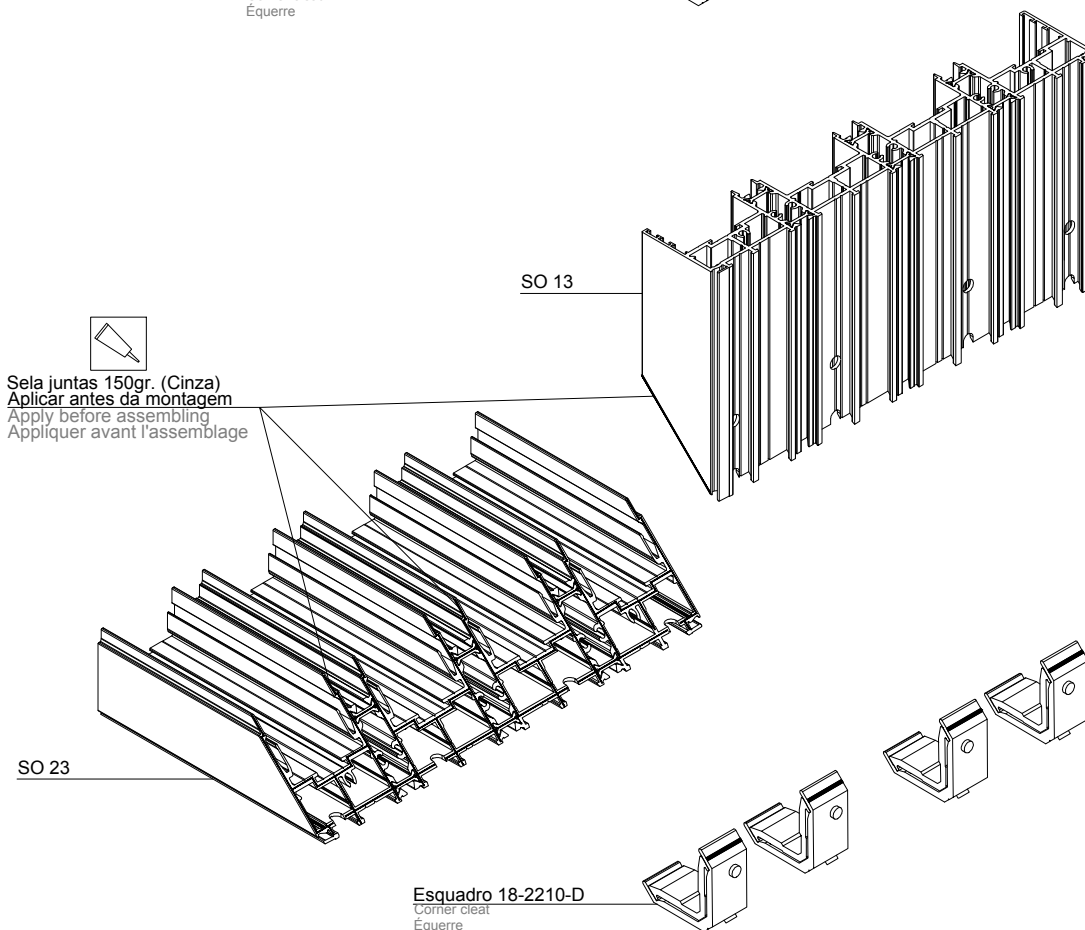
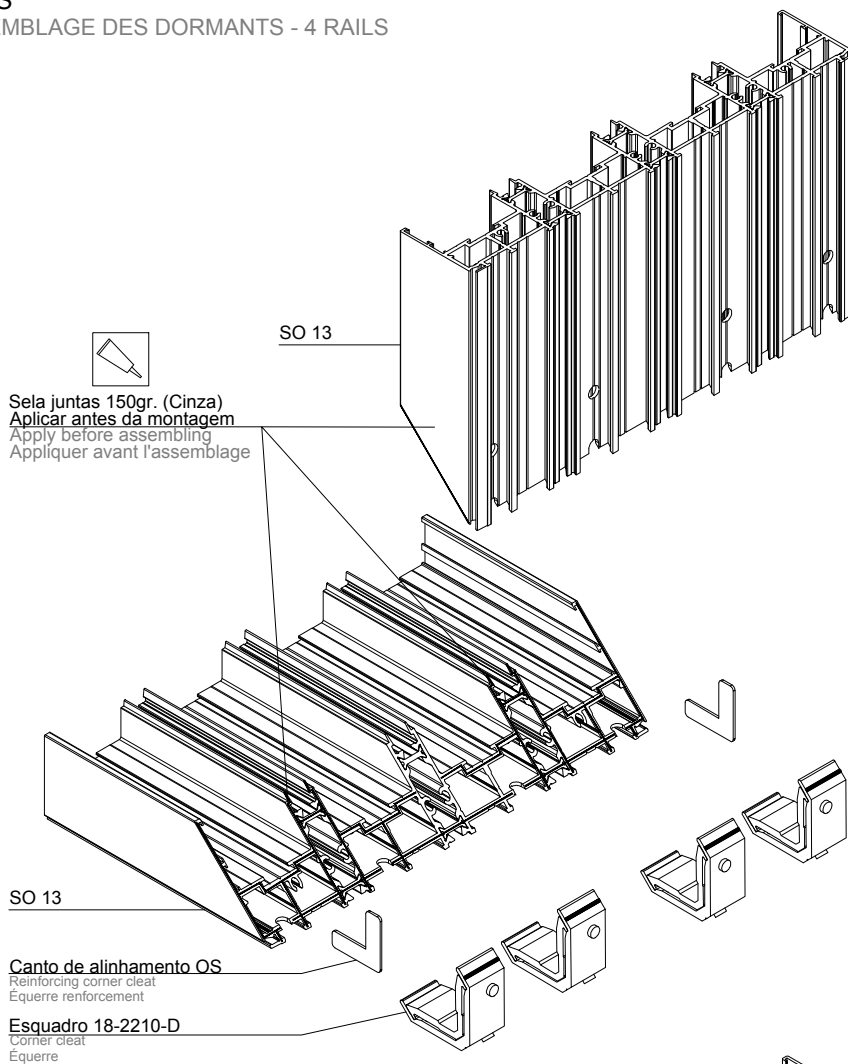

UNIÃO DO ARO 1 RAIL
1 RAIL FRAME UNION | UNION DE CADRE 1 RAIL

OPÇÃO FIXAÇÃO POR CIMA DO PERFIL
UPPER PROFILE FIXING OPTION | OPTION DE FIXATION SUR LE PROFILÉ

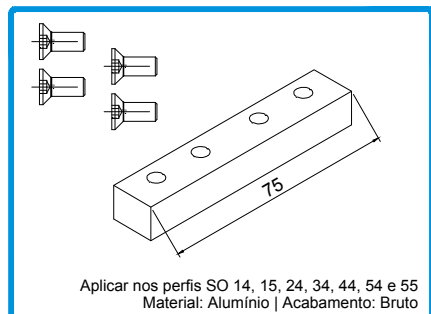

212956 CONJ. UNIÃO RETA 1-RAIL OS

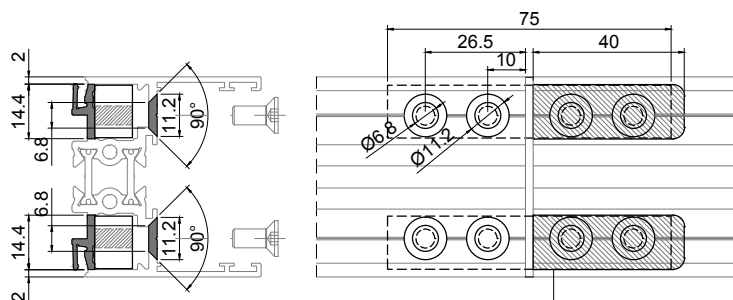

Maquinação opcional
Optional Machining
Usinage optionnelle

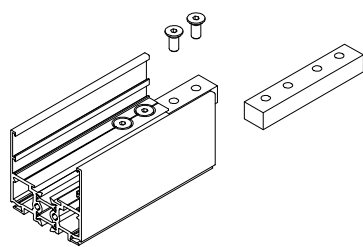

OPÇÃO LIGAÇÃO FRONTAL
FRONT LINK OPTION
OPTION CONNECTION DE FACE

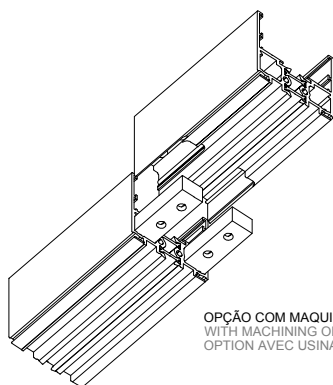

OPÇÃO COM MAQUINAÇÃO
WITH MACHINING OPTION
OPTION AVEC USINAGE

OPÇÃO FIXAÇÃO POR BAIXO DO PERFIL
BOTTOM PROFILE FIXING OPTION | OPTION DE FIXATION SOUS LE PROFILÉ

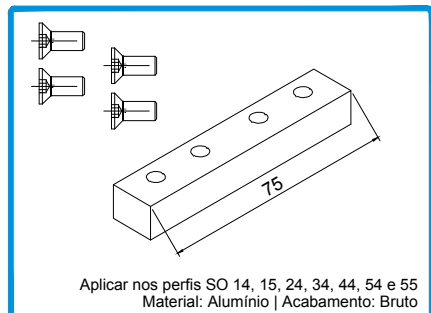

212956 CONJ. UNIÃO RETA 1-RAIL OS

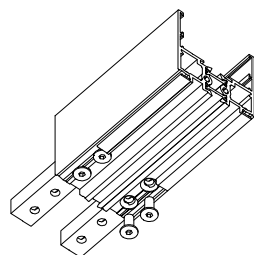
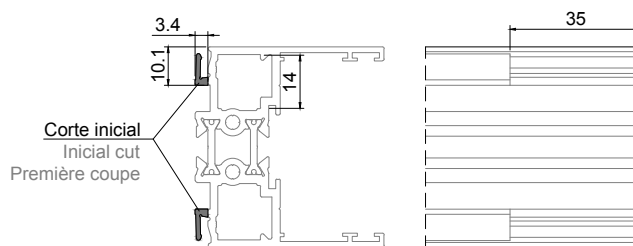

UNIÃO DO ARO 1 RAIL A 90°

90° 1 RAIL FRAME UNION | UNION DE CADRE 1 RAIL À 90°

OPÇÃO FIXAÇÃO POR CIMA DO PERFIL

UPPER PROFILE FIXING OPTION | OPTION DE FIXATION SUR LE PROFILÉ

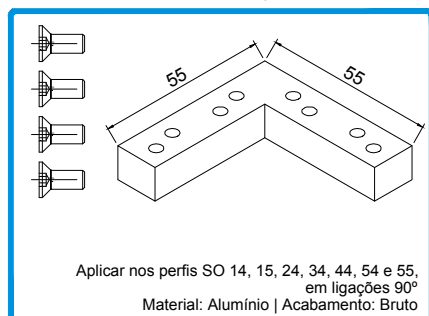

212957 CONJ. UNIÃO CANTO 90° 1-RAIL OS

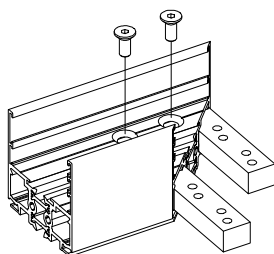

OPÇÃO LIGAÇÃO FRONTAL
FRONT LINK OPTION
OPTION CONNECTION DE FACE

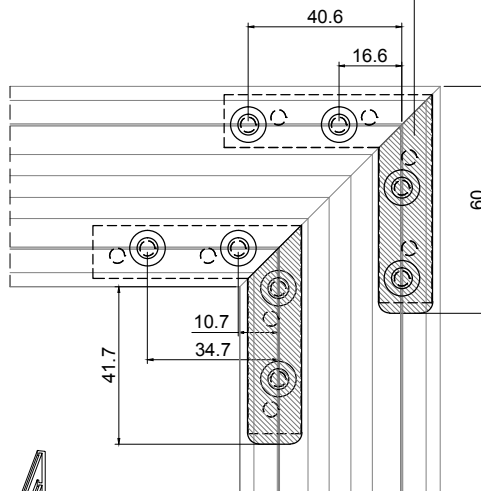
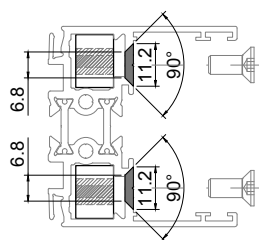

Maquinação opcional
Optional Machining
Usinage optionnelle

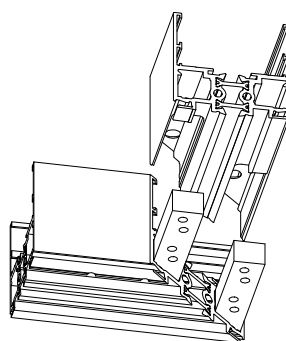

OPÇÃO COM MAQUINAÇÃO
WITH MACHINING OPTION
OPTION AVEC USINAGE

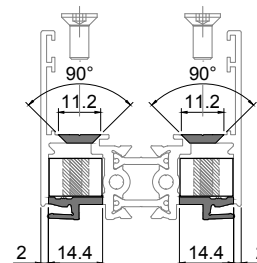

OPÇÃO FIXAÇÃO POR BAIXO DO PERFIL

BOTTOM PROFILE FIXING OPTION | OPTION DE FIXATION SOUS LE PROFILÉ

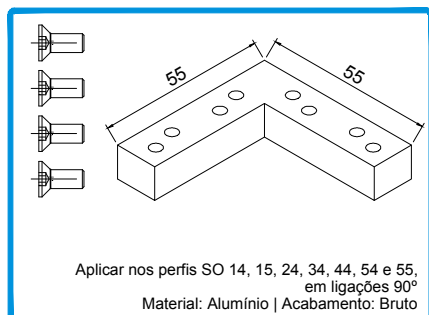

212957 CONJ. UNIÃO CANTO 90° 1-RAIL OS

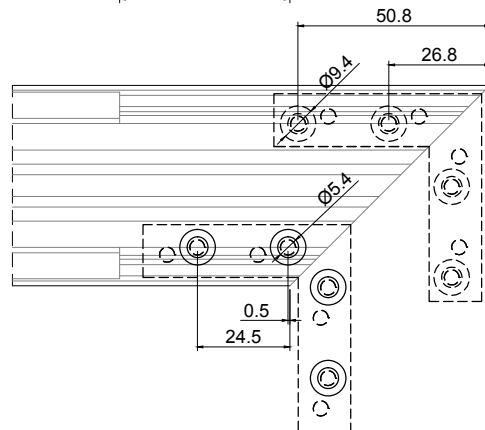
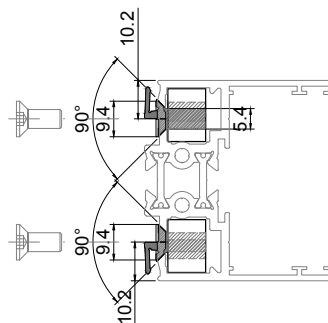
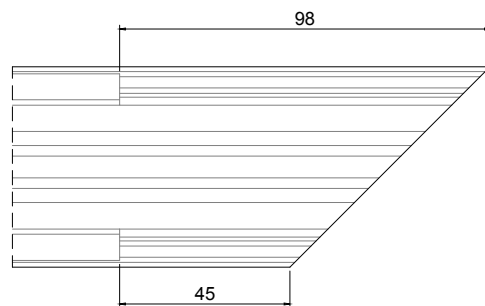
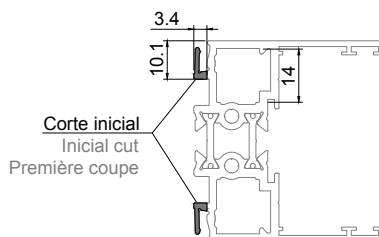
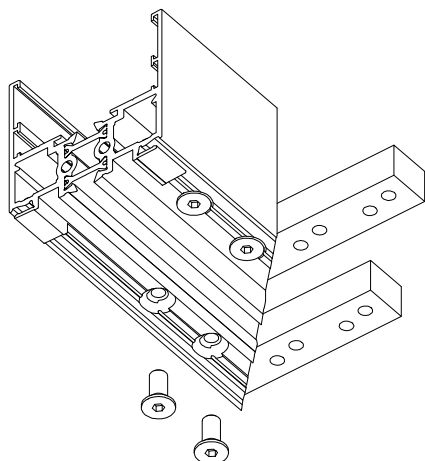

UNIÃO DO ARO 2 RAIL
2 RAIL FRAME UNION | UNION DE CADRE 2 RAIL

OPÇÃO FIXAÇÃO POR CIMA DO PERFIL
UPPER PROFILE FIXING OPTION | OPTION DE FIXATION SUR LE PROFILÉ

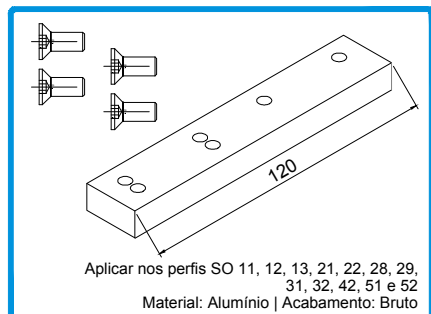

212953 CONJ. UNIÃO RETA OS

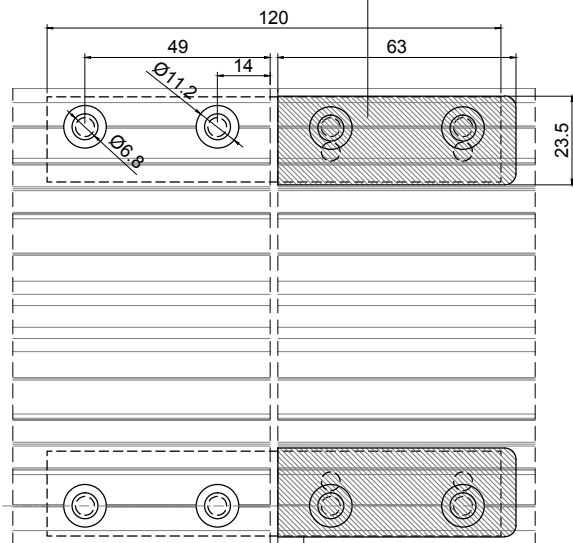
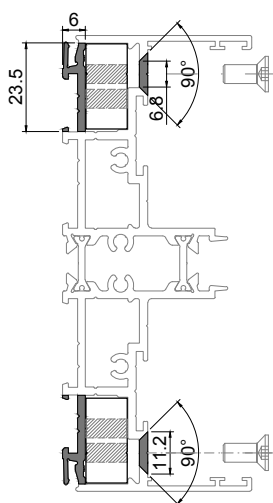

Maquinação opcional
Optional Machining
Usinage optionnelle

OPÇÃO LIGAÇÃO FRONTAL
FRONT LINK OPTION
OPTION CONNECTION DE FACE

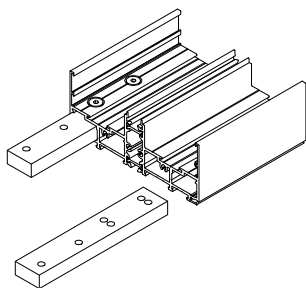

OPÇÃO COM MAQUINAÇÃO
WITH MACHINING OPTION
OPTION AVEC USINAGE

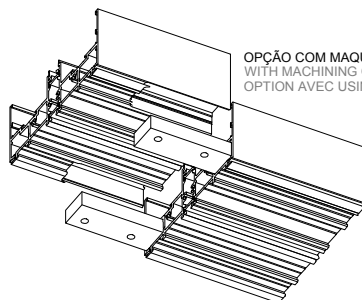

Maquinação opcional
Optional Machining
Usinage optionnelle

OPÇÃO FIXAÇÃO POR BAIXO DO PERFIL
BOTTOM PROFILE FIXING OPTION | OPTION DE FIXATION SOUS LE PROFILÉ

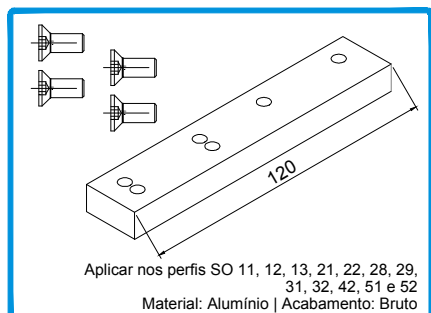

212953 CONJ. UNIÃO RETA OS

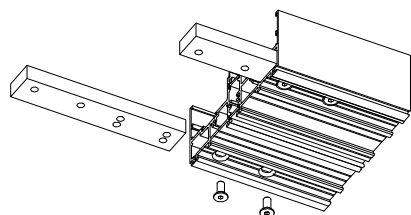
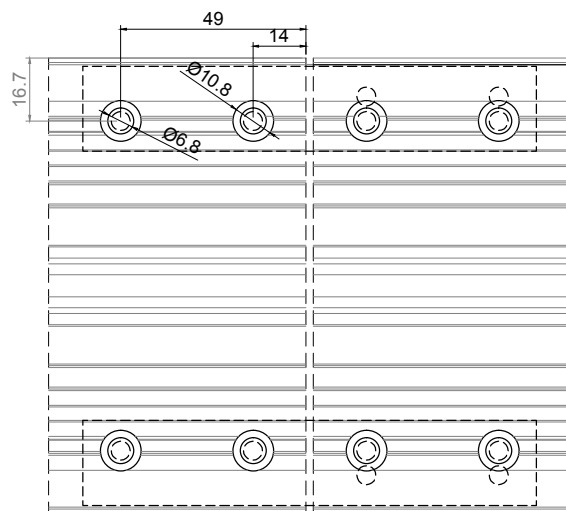
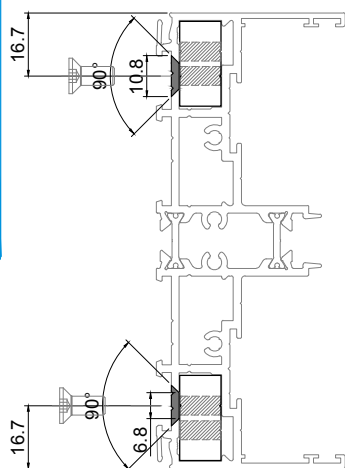

UNIÃO DO ARO 2 RAIL A 90°

90° 2 RAIL FRAME UNION | UNION DE CADRE 2 RAIL À 90°

OPÇÃO FIXAÇÃO POR CIMA DO PERFIL

UPPER PROFILE FIXING OPTION | OPTION DE FIXATION SUR LE PROFILÉ

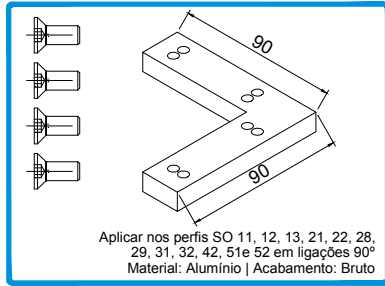

212954 CONJ. UNIÃO CANTO 90° OS

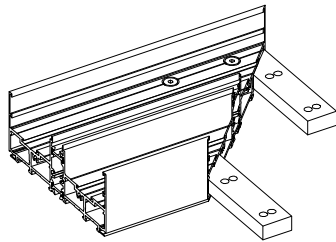

OPÇÃO LIGAÇÃO FRONTAL
FRONT LINK OPTION
OPTION CONNECTION DE FACE

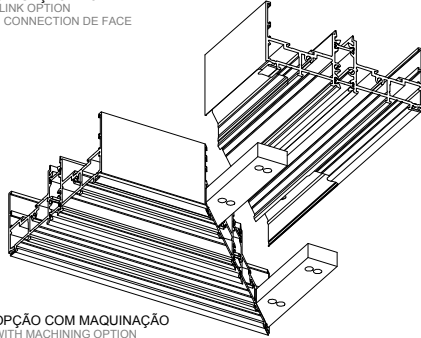

OPÇÃO COM MAQUINAÇÃO
WITH MACHINING OPTION
OPTION AVEC USINAGE

OPÇÃO FIXAÇÃO POR BAIXO DO PERFIL

BOTTOM PROFILE FIXING OPTION | OPTION DE FIXATION SOUS LE PROFILÉ

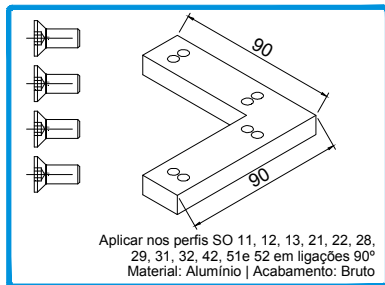

212954 CONJ. UNIÃO CANTO 90° OS

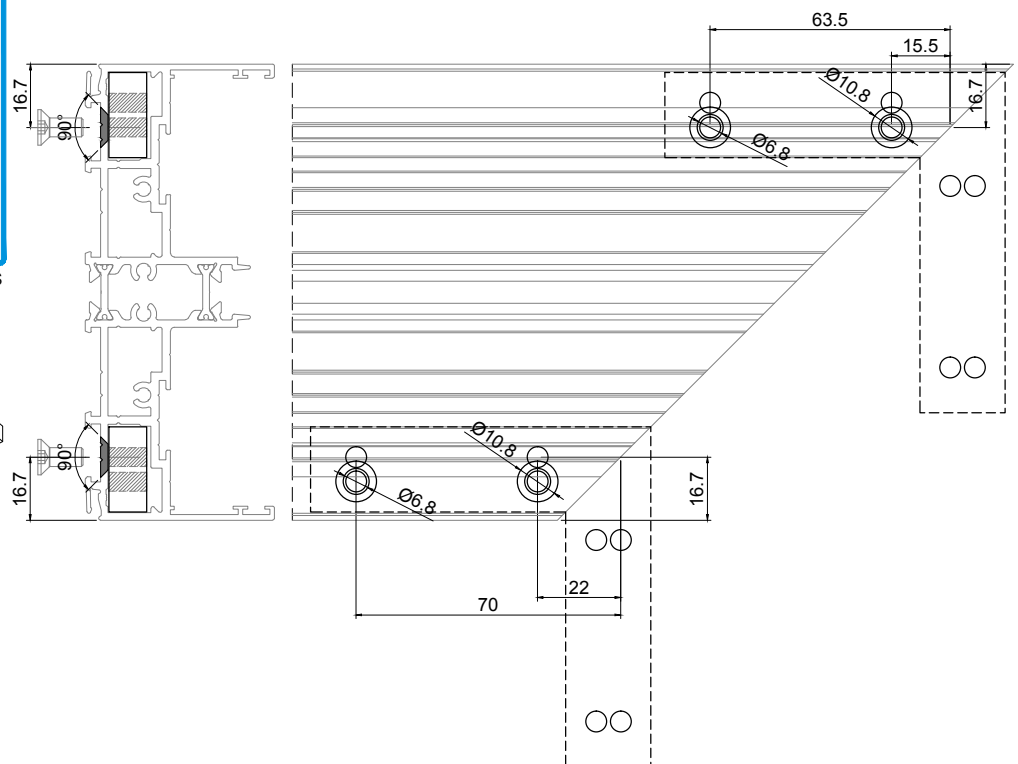
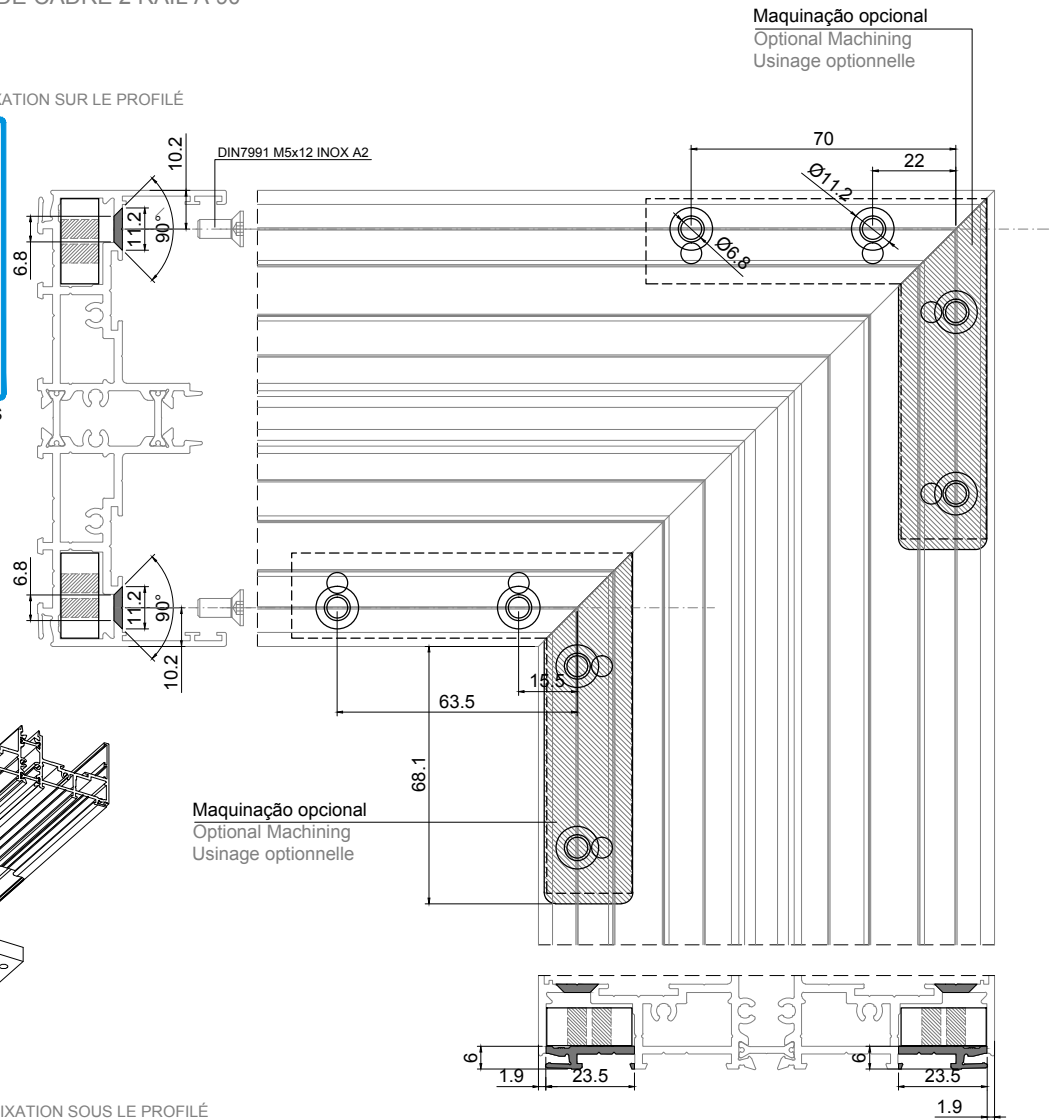
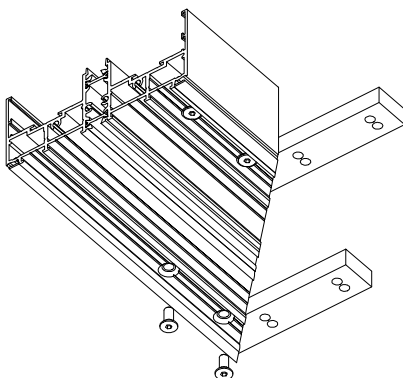

UNIÃO DO ARO 1 RAIL - SOLEIRA OCULTA

1 RAIL FRAME UNION - CONCEALED SILL | UNION DE CADRE 1 RAIL - SEUIL CACHÉE

OPÇÃO FIXAÇÃO POR CIMA DO PERFIL

UPPER PROFILE FIXING OPTION | OPTION DE FIXATION SUR LE PROFILÉ

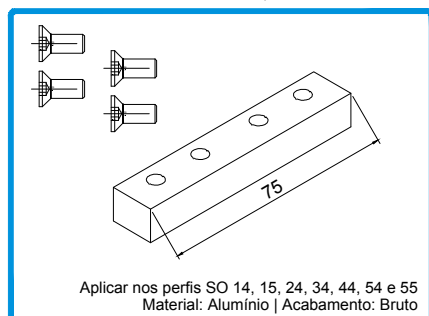

212956

CONJ. UNIÃO RETA 1-RAIL OS

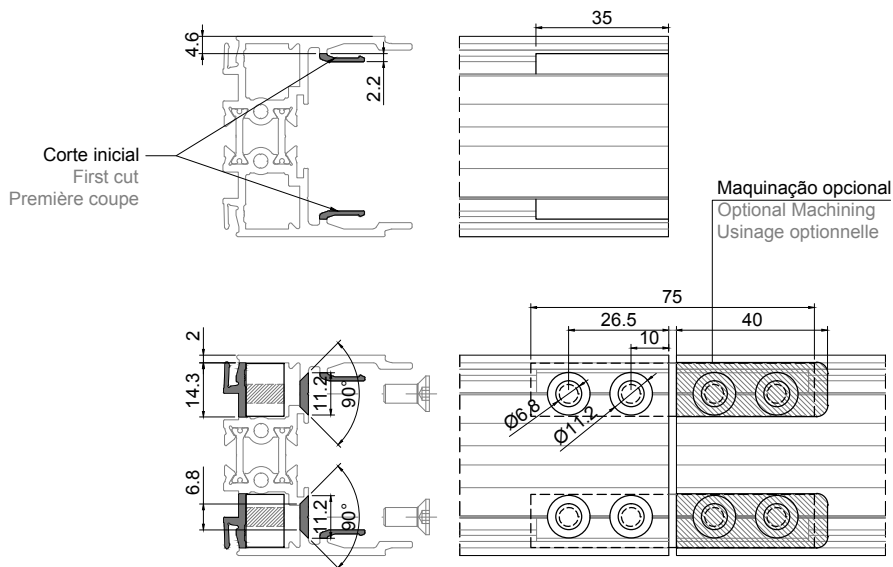

OPÇÃO FIXAÇÃO POR BAIXO DO PERFIL

BOTTOM PROFILE FIXING OPTION | OPTION DE FIXATION SOUS LE PROFILÉ

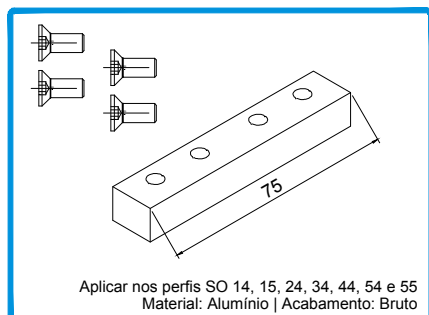

212956

CONJ. UNIÃO RETA 1-RAIL OS

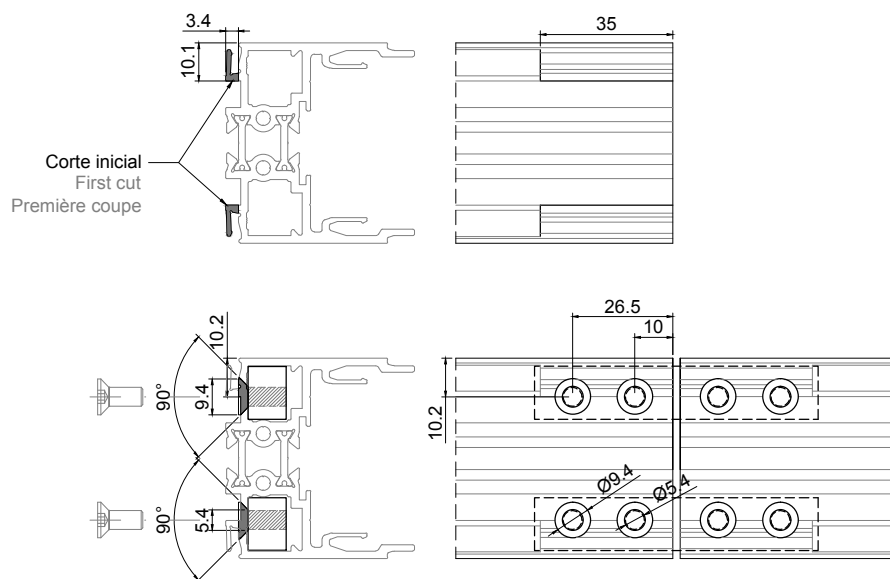

UNIÃO DO ARO 1 RAIL A 90° - SOLEIRA OCULTA

90° 1 RAIL FRAME UNION - CONCEALED SILL | UNION DE CADRE 1 RAIL À 90° - SEUIL CACHÉE

OPÇÃO FIXAÇÃO POR CIMA DO PERFIL

UPPER PROFILE FIXING OPTION | OPTION DE FIXATION SUR LE PROFILÉ

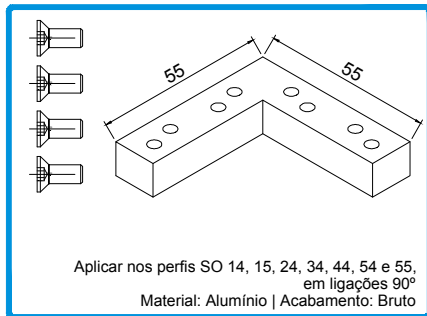

212957 CONJ. UNIÃO CANTO 90° 1-RAIL OS

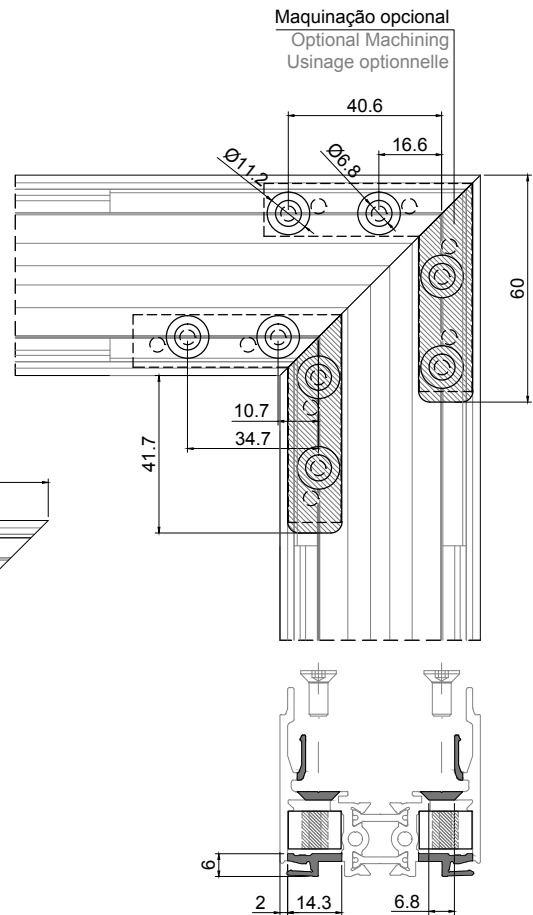
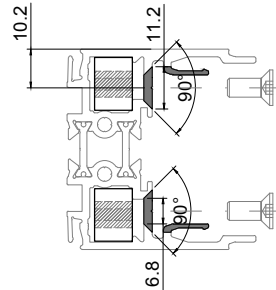
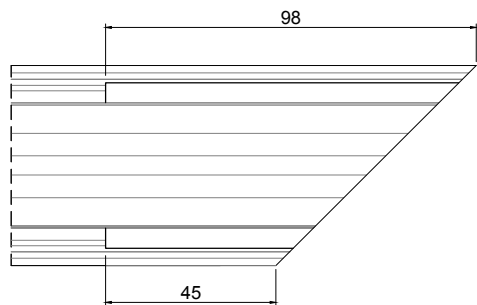
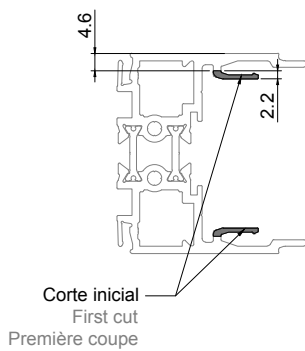

OPÇÃO FIXAÇÃO POR BAIXO DO PERFIL

BOTTOM PROFILE FIXING OPTION | OPTION DE FIXATION SOUS LE PROFILÉ

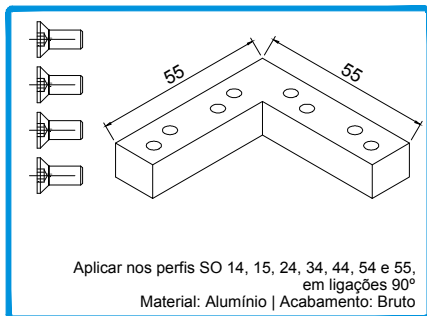

212957 CONJ. UNIÃO CANTO 90° 1-RAIL OS

Corte inicial
First cut
Première coupe

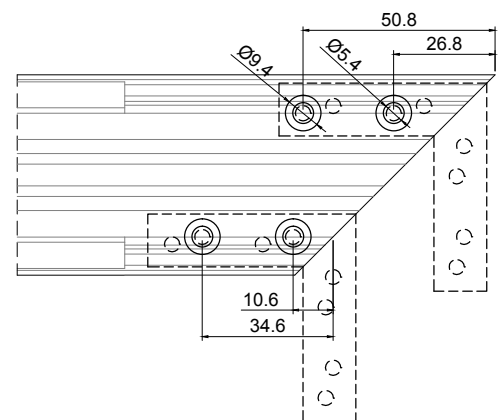
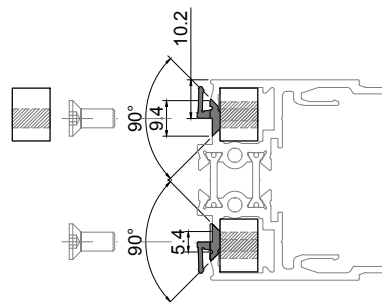
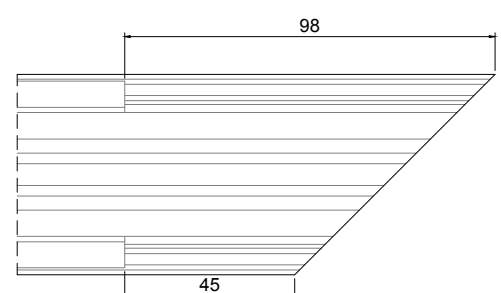
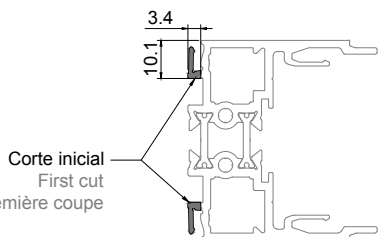

UNIÃO DO ARO 2 RAIL - SOLEIRA OCULTA

2 RAIL FRAME UNION - CONCEALED SILL | UNION DE CADRE 2 RAIL - SEUIL CACHÉE

OPÇÃO FIXAÇÃO POR CIMA DO PERFIL

UPPER PROFILE FIXING OPTION | OPTION DE FIXATION SUR LE PROFILÉ

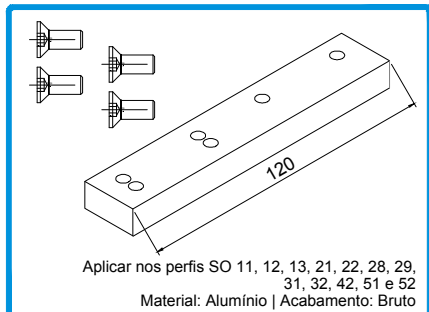

212953

CONJ. UNIÃO RETA OS

Corte inicial
First cut
Première coupe

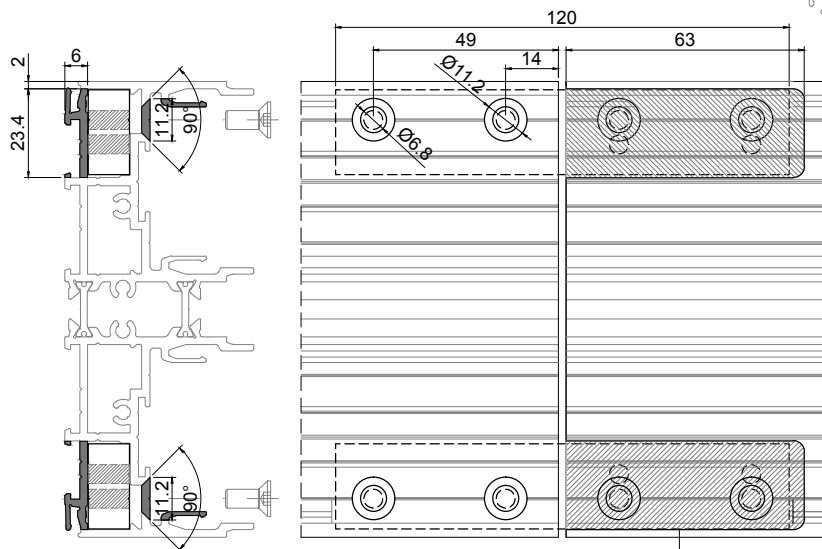
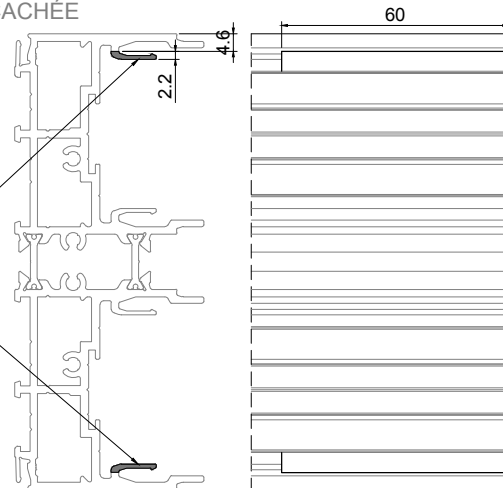

Maquinação opcional
Optional Machining
Usinage optionnelle

OPÇÃO FIXAÇÃO POR BAIXO DO PERFIL

BOTTOM PROFILE FIXING OPTION | OPTION DE FIXATION SOUS LE PROFILÉ

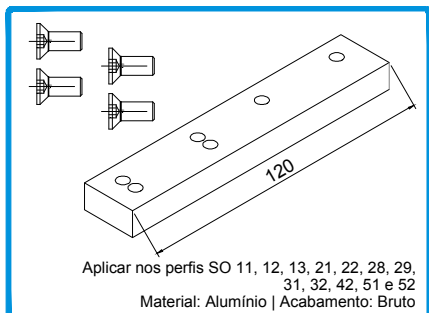

212953

CONJ. UNIÃO RETA OS

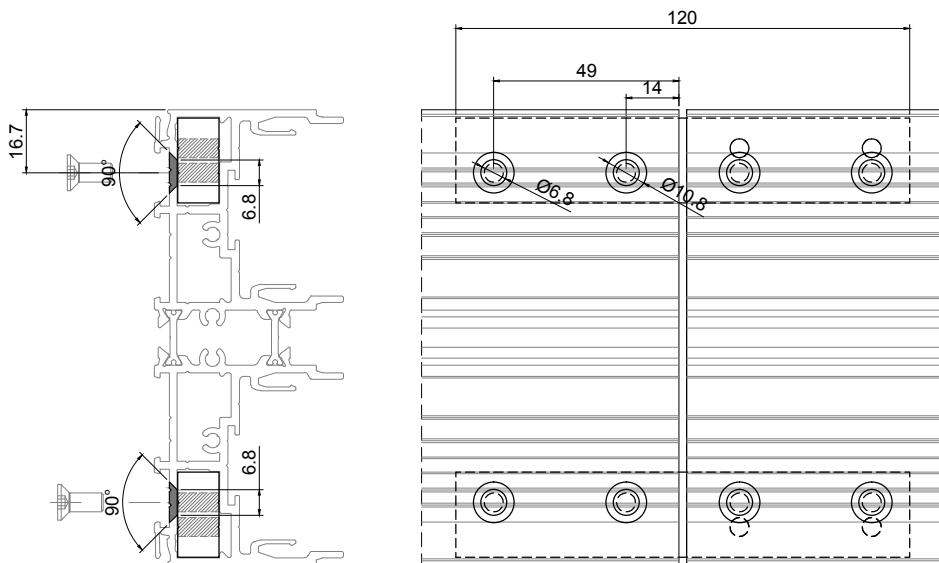

UNIÃO DO ARO 2 RAIL A 90° - SOLEIRA OCULTA

90° 2 RAIL FRAME UNION - CONCEALED SILL | UNION DE CADRE 2 RAIL À 90° - SEUIL CACHÉE

OPÇÃO FIXAÇÃO POR CIMA DO PERFIL

UPPER PROFILE FIXING OPTION | OPTION DE FIXATION SUR LE PROFILÉ

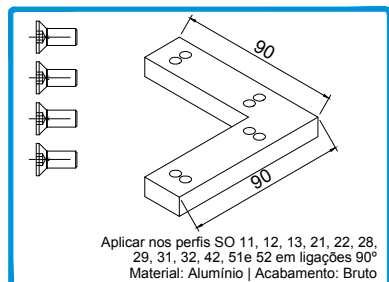

212954

CONJ. UNIÃO CANTO 90° OS

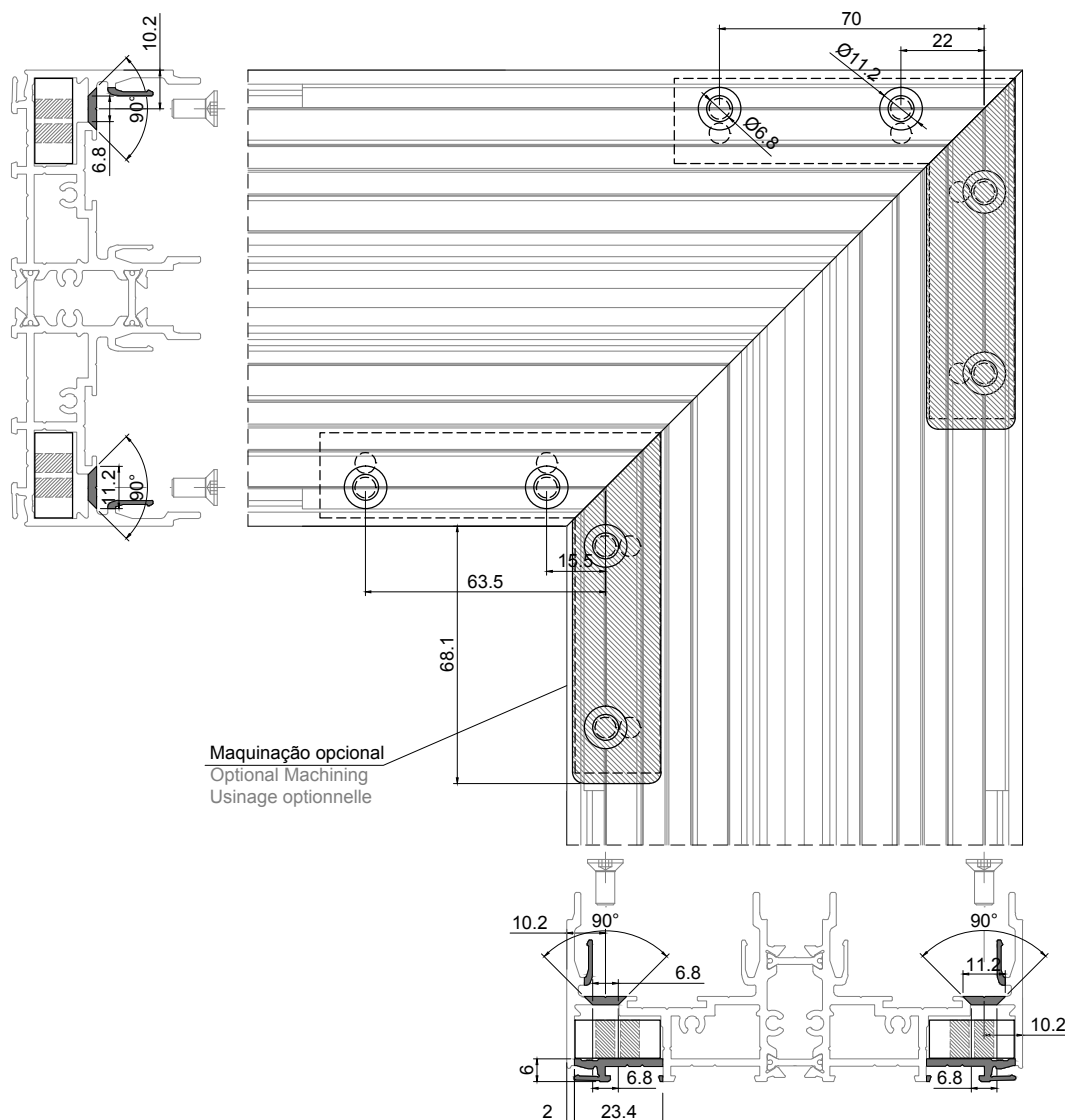
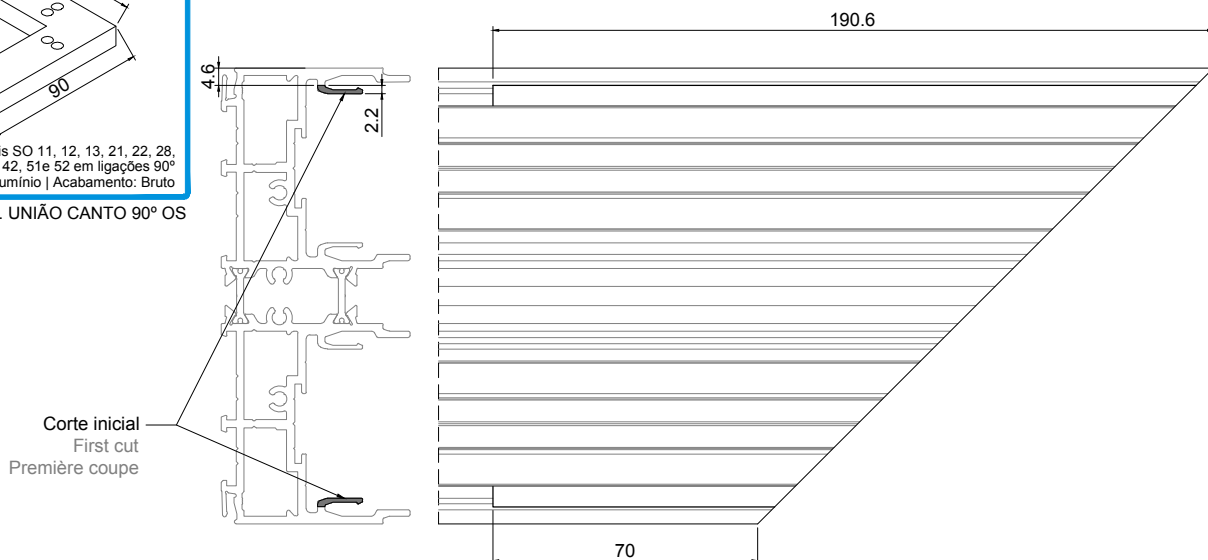

UNIÃO DO ARO 2 RAIL A 90° - SOLEIRA OCULTA

90° 2 RAIL FRAME UNION - CONCEALED SILL | UNION DE CADRE 2 RAIL À 90° - SEUIL CACHÉE

OPÇÃO FIXAÇÃO POR BAIXO DO PERFIL

BOTTOM PROFILE FIXING OPTION | OPTION DE FIXATION SOUS LE PROFILÉ

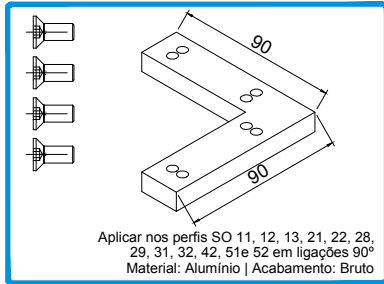

212954

CONJ. UNIÃO CANTO 90° OS

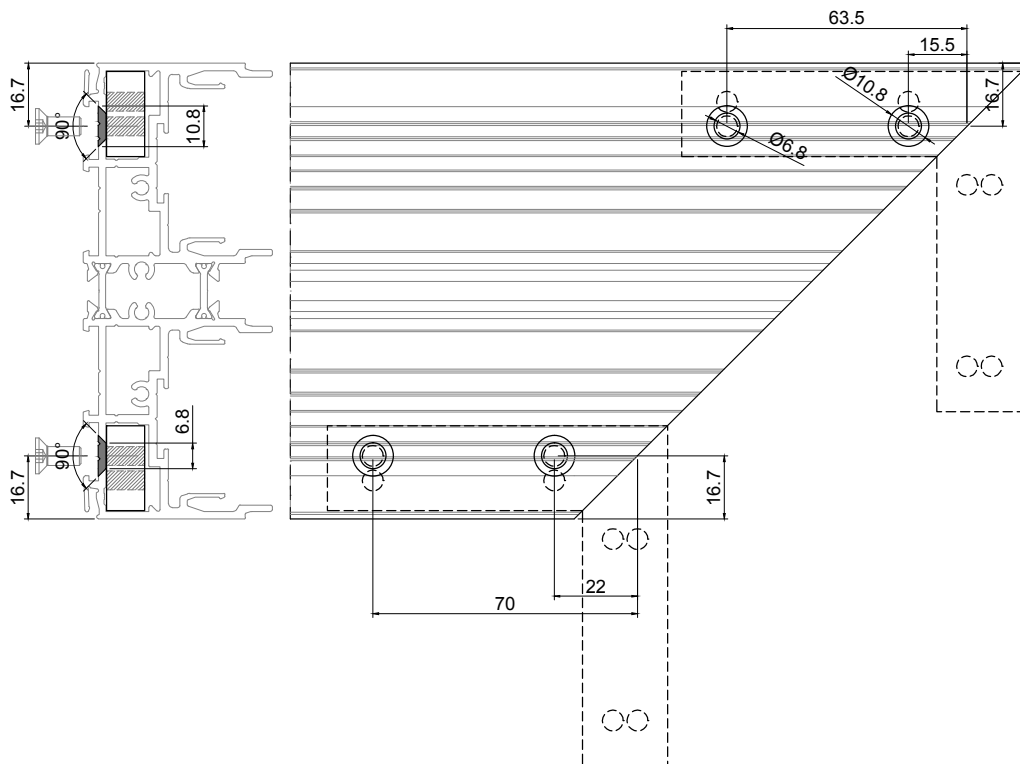

MAQUINAÇÕES PARA EMENDA DA GUIA INOX
STAINLESS STEEL GUIDE EXPANSION AND MEND DETAIL
USINAGES POUR AMENDMENT DE LA GUIDE D'ACIER INOXYDABLE

PASSO | STEP | ÉTAPE 1:

Com a guia aplicada no vedante e na soleira, furar conforme esquema e abrir rosca M3 no alumínio.
With the guide applied in the seal and the sill, drill as per the scheme and thread in the alumum.
Avec le guide appliqué sur le joint et le seuil, percez selon le schéma et filetage en aluminium.

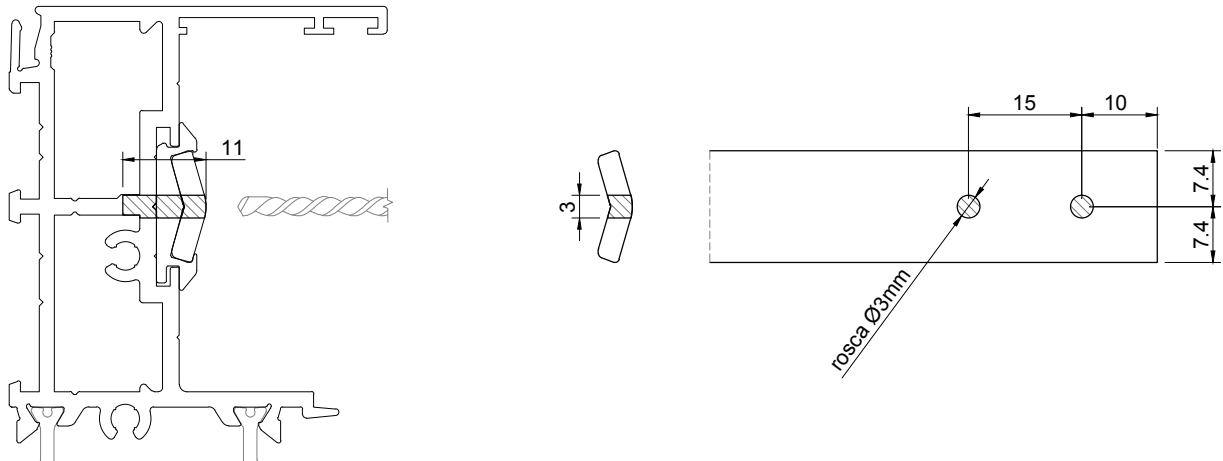

PASSO | STEP | ÉTAPE 2:

Retirar a guia do vedante e escarear os furos conforme esquema.
Remove the guide from the joint and countersink the holes according to the scheme.
Retirez le guide de joint et fraiser les trous selon le schéma.

Desta forma conseguimos garantir que os parafusos ficam embutidos na guia e não comprometem o deslizamento dos carrinhos.
This way we can ensure that the screws are embedded in the guide and do not compromise the sliding of the roller bearings.
De cette façon, nous pouvons nous assurer que les vis sont encastrées dans le guide et ne compromettent pas le glissement des rouleaux.

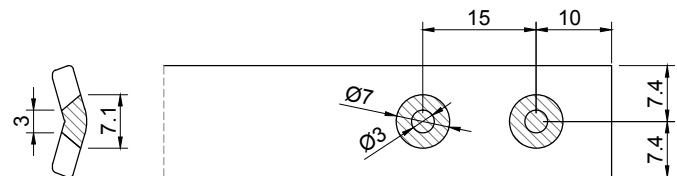

PASSO | STEP | ÉTAPE 3:

Com a guia novamente no vedante e na soleira, aplicar os parafusos.
With the guide back on the seal and the threshold, apply the screws.
Avec le guide en arrière sur le joint et le seuil, appliquez les vis.

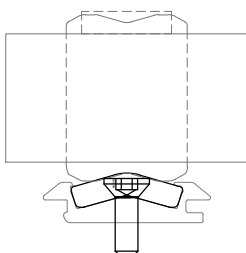

290016 Para fixação dos Topos
PARAFUSO FIXAÇÃO DE TOPOS

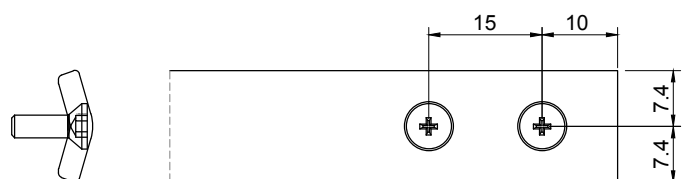

PORMENOR DE DILATAÇÃO E EMENDA DA GUIA INOX
STAINLESS STEEL GUIDE EXPANSION AND MEND DETAIL
DÉTAIL DE DILATATION ET AMENDMENT DE LA GUIDE D'ACIER INOXYDABLE

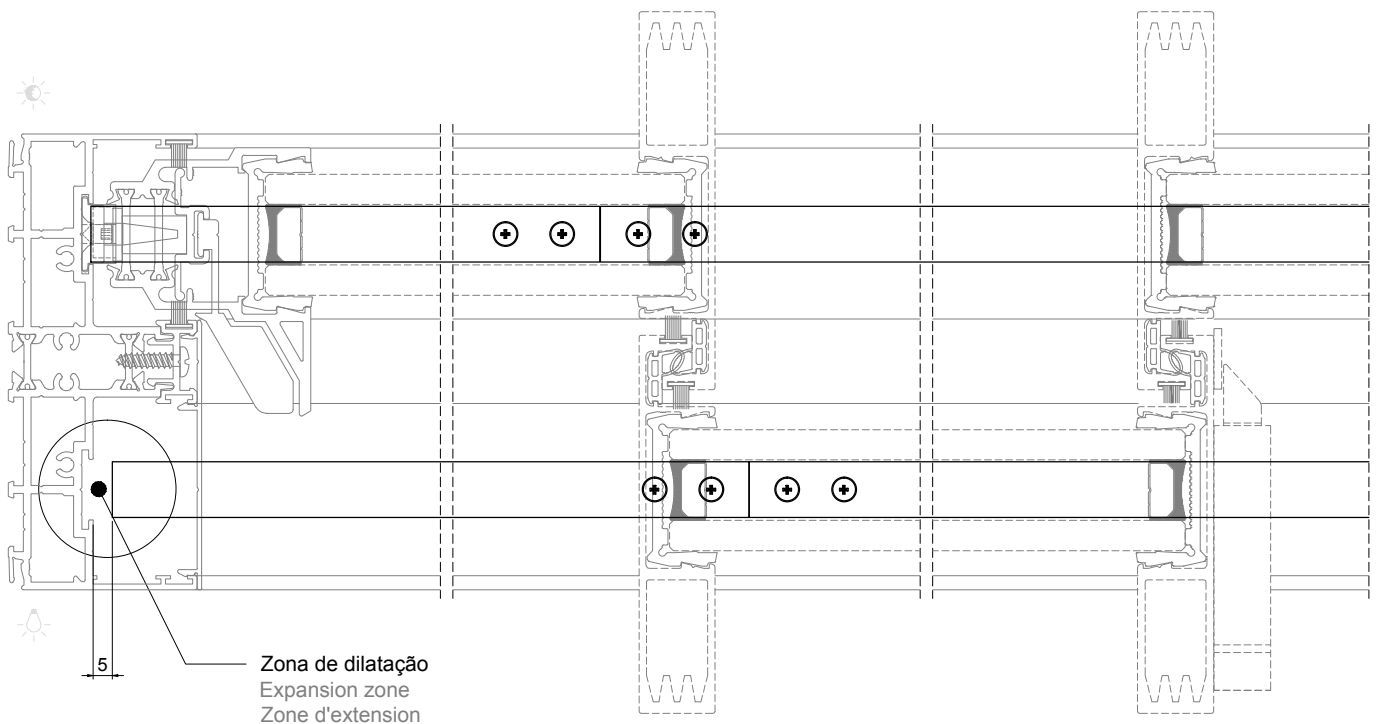
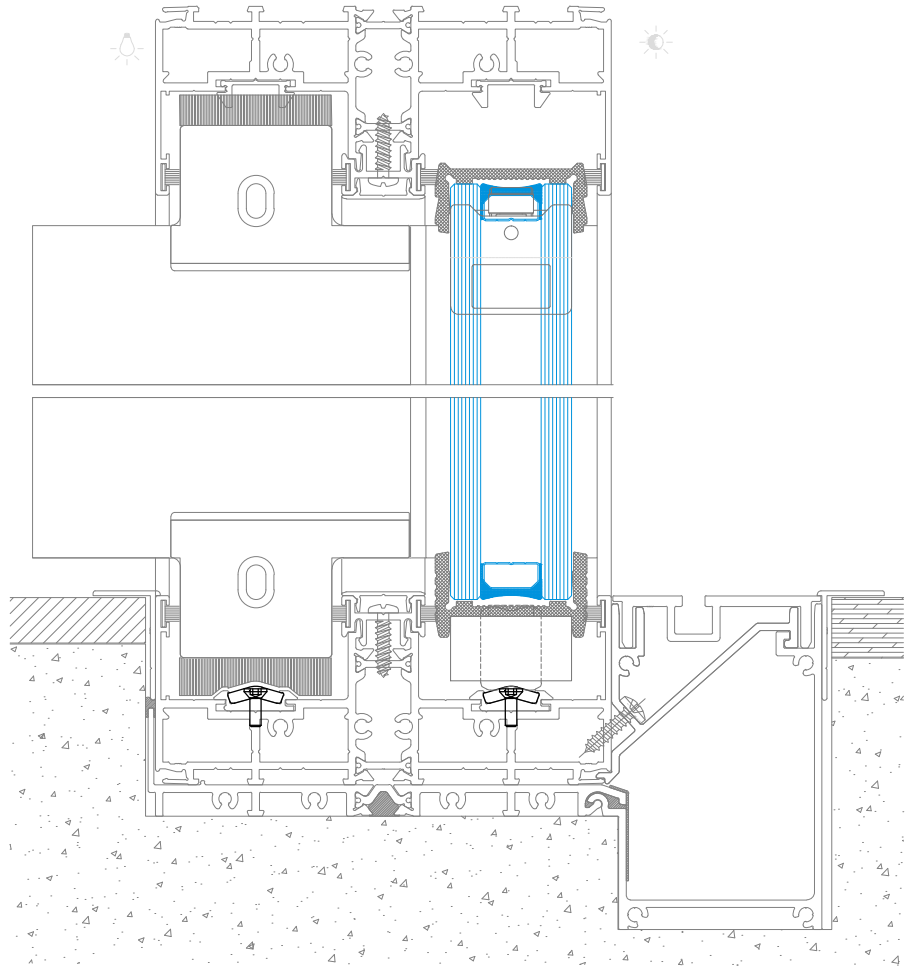
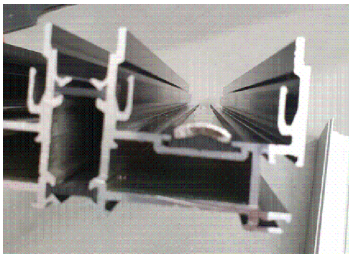

NOTA: Solução a considerar quando a dimensão do vão é superior ao comprimento do perfil guia.
NOTE: Solution to consider when the frame dimension is greater than the guide profile length.
NOTE: Solution à considérer lorsque la dimension de travée est supérieure à la longueur du profilé de la guide.

POSICIONAMENTO DOS CORTA-VENTO
CENTRAL GASKET POSITIONING
POSITIONNEMENT DES BROSE D'ÉTANCHÉITÉ

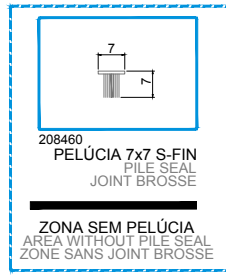

Tipologia: 3 folhas tri-rail
Typology: 3 leaves - 3-rail
Typologie: 3 vantaux - 3-rail

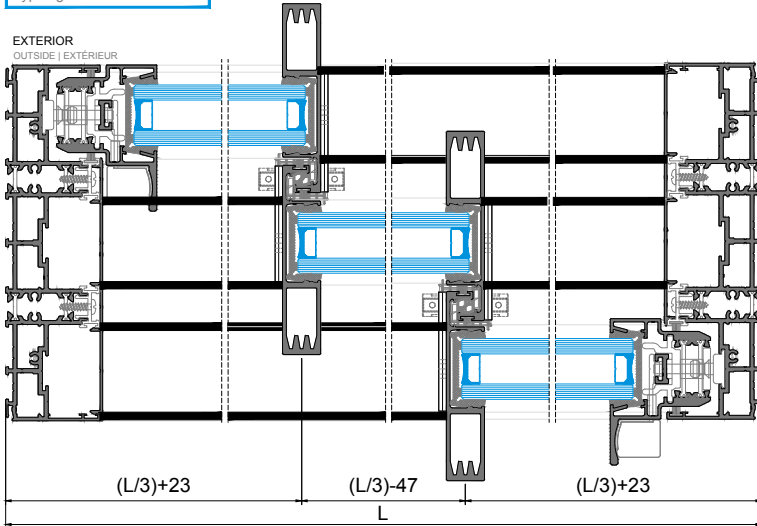

Tipologia: 3 folhas bi-rail
Typology: 3 leaves - 2-rail
Typologie: 3 vantaux - 2-rail

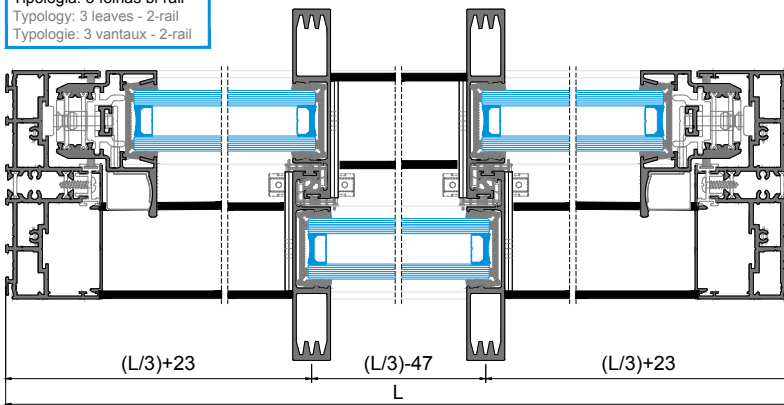

Tipologia: 4 folhas bi-rail
Typology: 4 leaves - 2-rail
Typologie: 4 vantaux - 2-rail

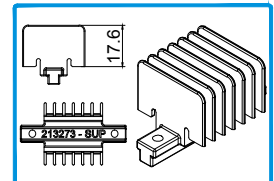
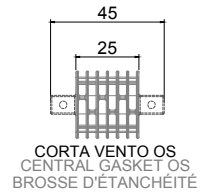
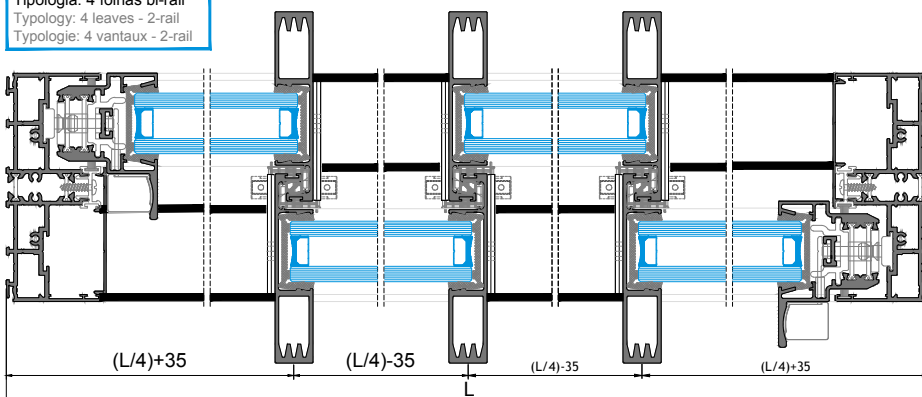

213273 CORTA VENTO SUP. OS
UPPER CENT. GASKET OS
BROSSE D'ÉTANCHÉITÉ
SUPÉRIEUR OS

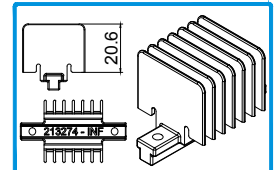

213274 CORTA VENTO INF. OS
LOWER CENT. GASKET OS
BROSSE D'ÉTANCHÉITÉ
INFÉRIEUR OS

PORMENOR DE APLICAÇÃO
APPLICATION DETAIL
DÉTAIL D'APPLICATION

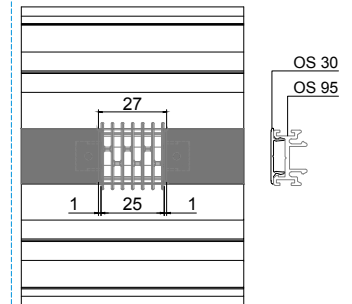

Interromper os perfis OS 30 e OS 95 em 27mm
Interrupt the OS 30 and OS 95 profiles in 27mm
Arrêter des profilés OS 30 et OS 95 en 27mm

DRENAGEM DO CORTA-VENTO
CUT WIND DRAINAGE
DRAINAGE DU BROSE D'ÉTANCHÉITÉ

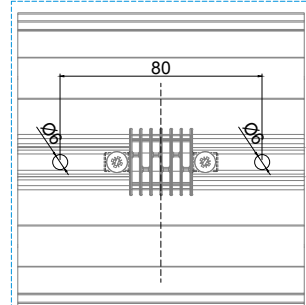

Execução de 2 furos no aro fixo com 6mm, distanciados de 40mm do centro do corta vento, para cada um dos lados
Execution of 2 holes in the fixed frame, 40mm apart from the center of the cut wind, for each side
Exécution de deux trous dans le châssis fixe avec 6 mm, 40 mm en dehors du centre du brosse d'étanchéité, pour chaque côté

POSICIONAMENTO DOS CORTA-VENTO INFERIORES PARA SOLEIRA OCULTA
INFERIOR CENTRAL GASKET POSITIONING FOR CONCEALED SILL
POSITIONNEMENT DES BROSSE D'ÉTANCHÉITÉ INFÉRIEURES POUR SEUIL CACHÉE

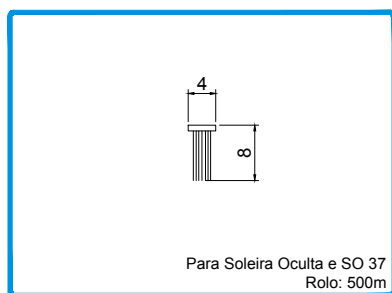
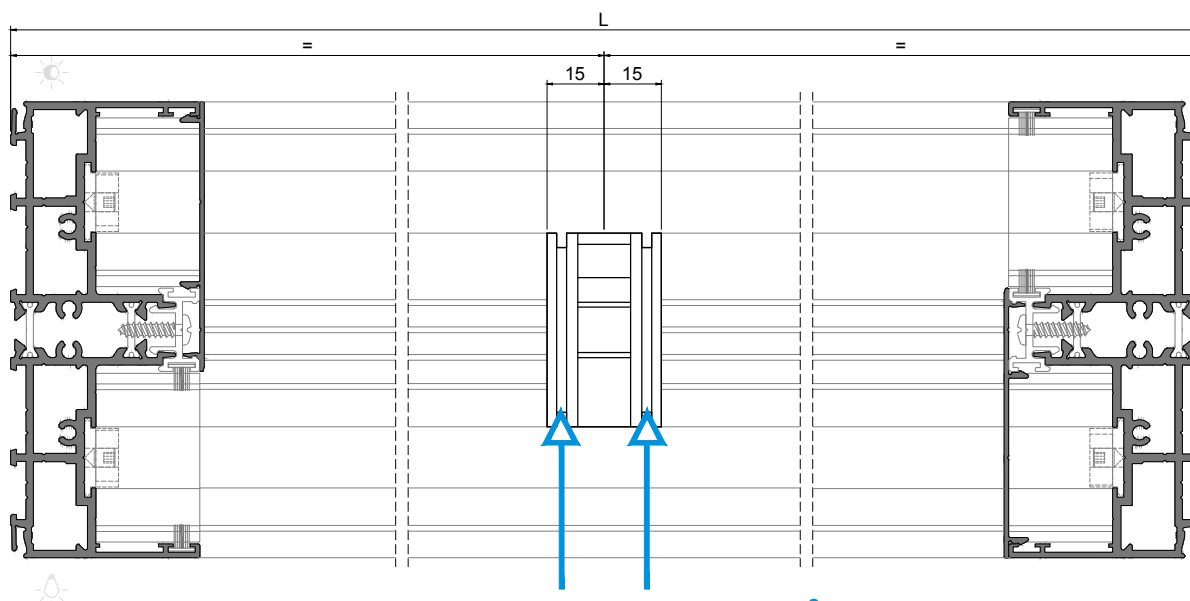
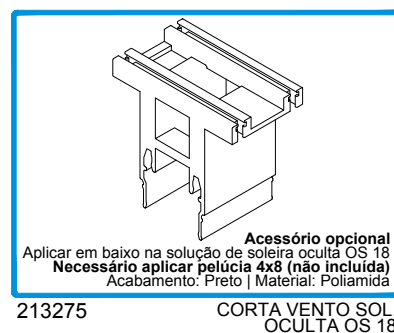
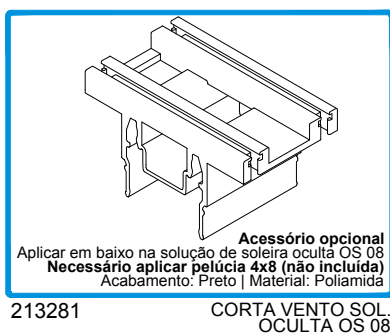

208468 PELÚCIA SRF 4X8 2P1M Cinza
208469 PELÚCIA SRF 4X8 2P1M Preta

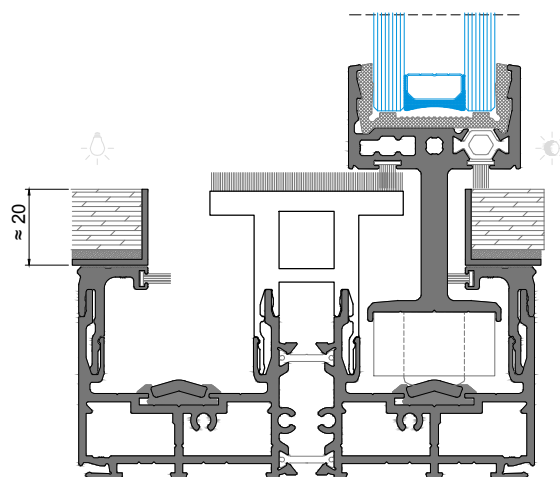
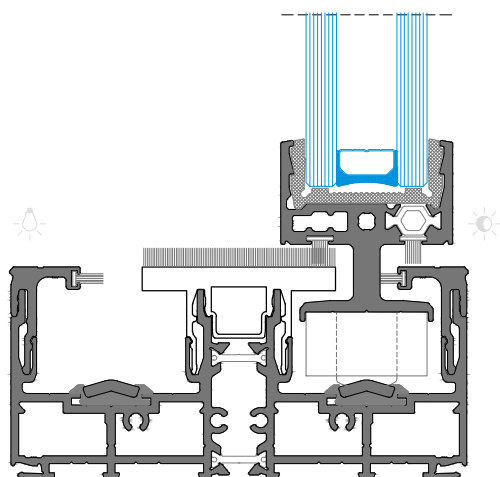
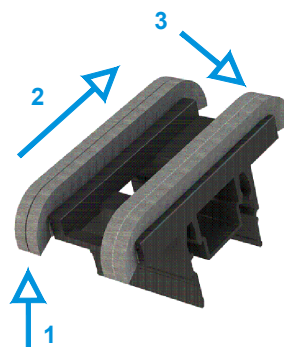

POSICIONAMENTO DAS CHAPAS E DOS TOPOS BLOQUEIO PELÚCIA
PILE SEAL LOCK PLATES AND END-CAPS POSITIONING
POSITIONNEMENT DES PLAQUES ET DES EMBOUT DE VERROUILLAGE DE JOINT BROSSE

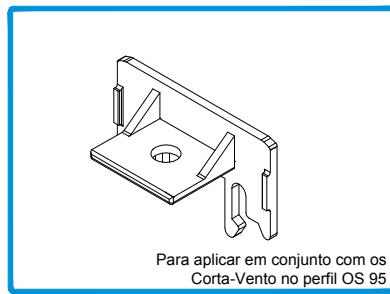

Para aplicar em conjunto com os
Corta-Vento no perfil OS 95

210510 TOPO BLOQUEIO PELÚCIA CV
PILE SEAL LOCK END-CAP CV
EMBOUT DE VERROUILLAGE DE JOINT
BROSSE CV

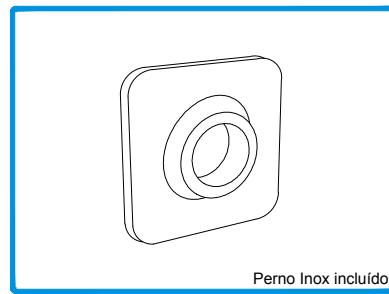

Perno Inox incluído

215194 CHAPA BLOQUEIO PELÚCIA
PILE SEAL LOCK PLATE
PLAQUE DE VERROUILLAGE DE JOINT
BROSSE

PASSO | STEP | ÉTAPE 1:

Colocar os Corta-vento e as Poliamidas OS 95.
Place the Cut-wind and the OS 95 Polyamides.
Installer les Brosse d'Étanchéité et des Polyamides OS 95.

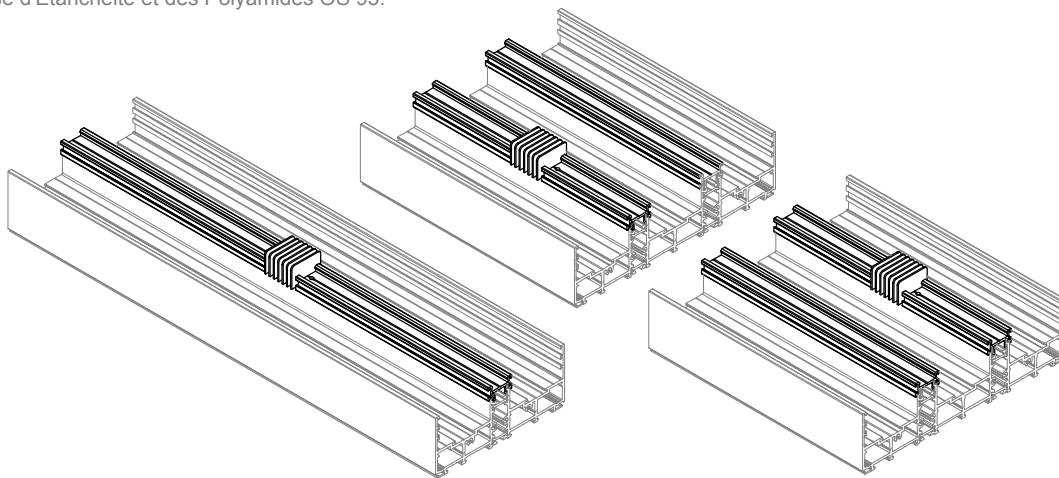

PASSO | STEP | ÉTAPE 2:

Aplicar um Topo Bloqueio Pelúcia CV de cada lado do Corta-Vento e fixar com paraf. CQ DIN7981 2,9x22 ou silicone.
Apply one PILE SEAL Lock End-cap CV on each side of the Cut-wind and fix with screw CQ DIN7981 2,9x22 or silicone.
Appliquez un Embout de Verrouillage de Joint Brosse CV de chaque côté du et fixe avec vis CQ DIN7981 2,9x22 ou du silicone.

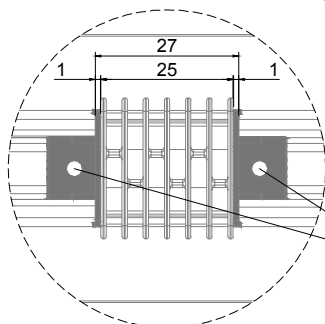
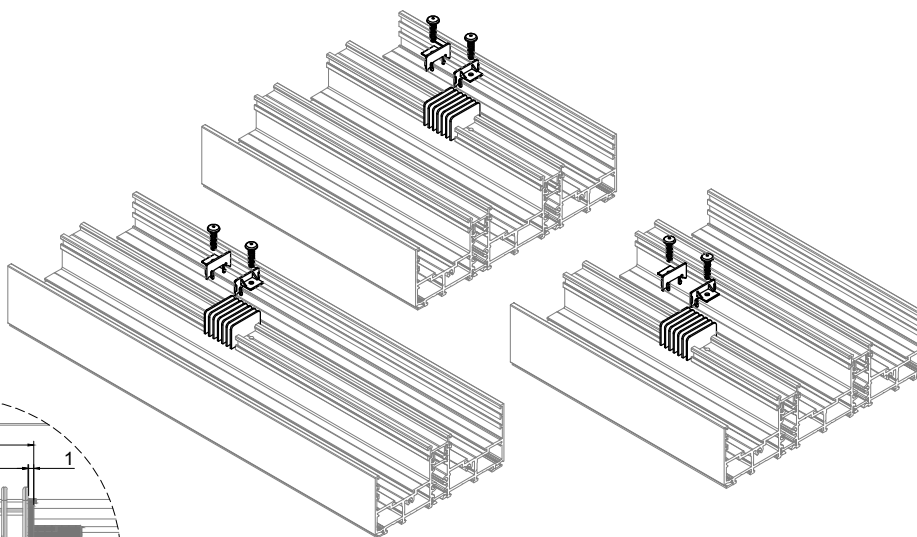

PARAFUSO CQ DIN7981 2,9x22 OU SILICONE
SCREW CQ DIN7981 2,9x22 OR SILICONE
VIS CQ DIN7981 2,9x22 OU SILICONE

POSICIONAMENTO DAS CHAPAS E DOS TOPOS BLOQUEIO PELÚCIA
PILE SEAL LOCK PLATES AND END-CAPS POSITIONING
POSITIONNEMENT DES PLAQUES ET DES EMBOUT DE VERROUILLAGE DE JOINT BROSSE

PASSO | STEP | ÉTAPE 3:

Introduzir uma Chapa Bloqueio Pelúcia (A) em cada canal de pelúcia do perfil. Colocar de seguida a pelúcia até alcançar o fim da zona onde estarão as folhas móveis na posição fechada (aproximadamente na linha do corta-vento). Fixar a chapa de bloqueio através do perno.

Insert a PILE SEAL Lock Plate (A) in each PILE SEAL channel of the profile. Then place the PILE SEAL until it reaches the end of the area where the movable leaves will be in the closed position (approximately on the cut-wind line). Secure the locking plate with the pin.

Insérez une Plaque de Verrouillage de Joint Brosse (A) dans chaque canal de joint brosse du profilé. Placez ensuite la joint jusqu'à ce qu'elle atteigne l'extrémité de la zone où les vantaux mobiles seront en position fermée (approximativement sur la ligne de brosse d'étanchéité). Bloquez la plaque de verrouillage avec la goupille.

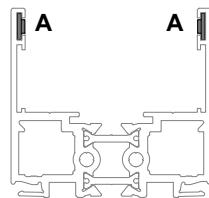
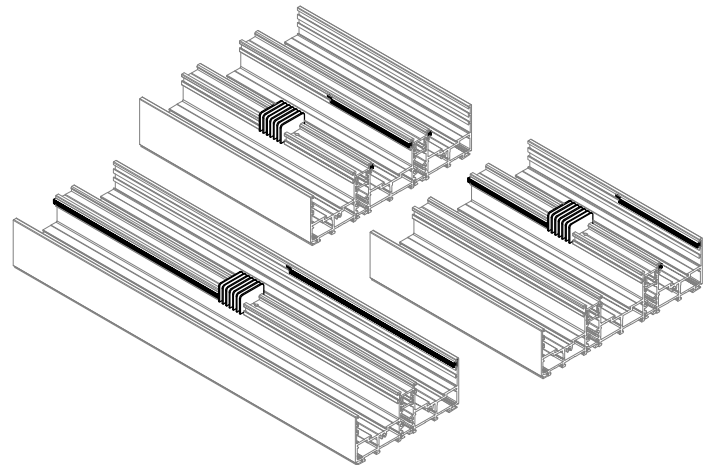

SO 14

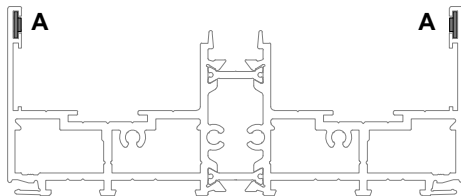

SO 11

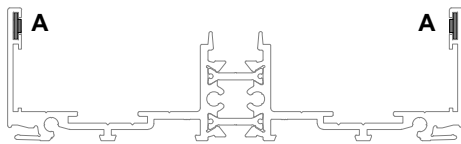

SO 05

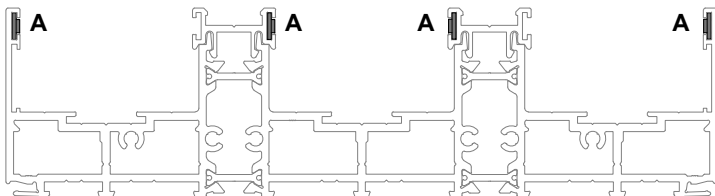

SO 12

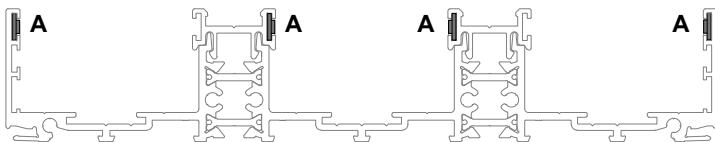

SO 06

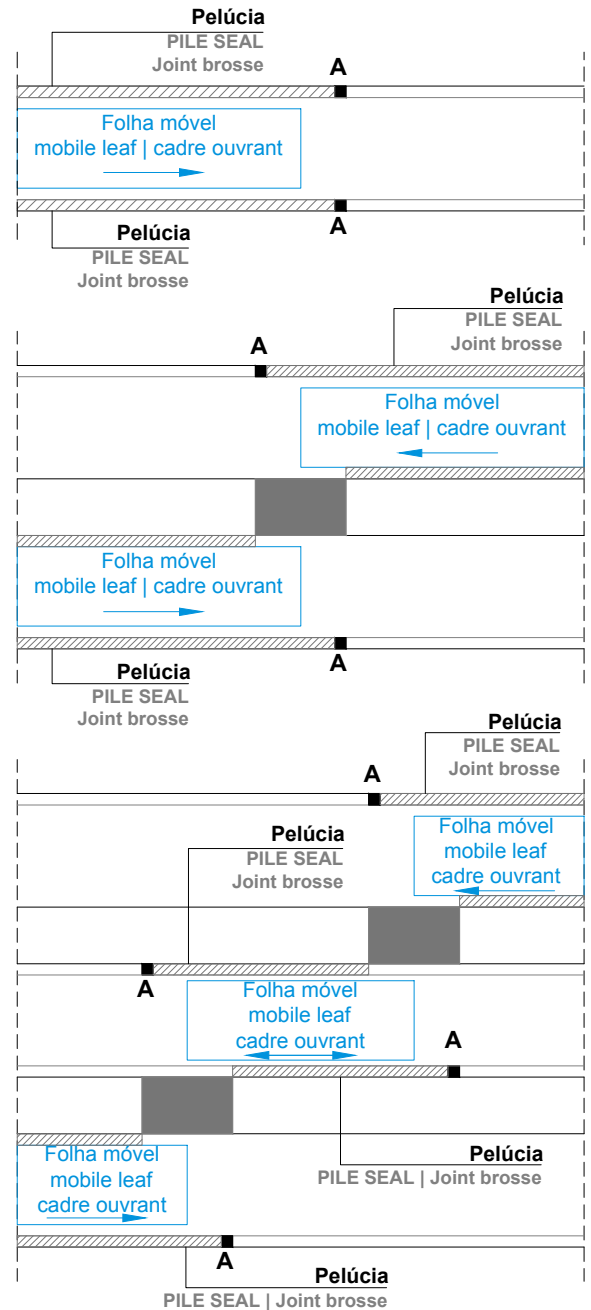

POSICIONAMENTO DAS CHAPAS E DOS TOPOS BLOQUEIO PELÚCIA
PILE SEAL LOCK PLATES AND END-CAPS POSITIONING
POSITIONNEMENT DES PLAQUES ET DES EMBOUT DE VERROUILLAGE DE JOINT BROSSE

PASSO 4: Depois de fixar os Topos de Bloqueio de Pelúcia CV, podem aplicar-se normalmente as tampas OS 30.
STEP 4: After fixing the PILE SEAL Lock End-caps CV, the OS 30 covers can be applied normally.
ÉTAPE 4 : Après avoir fixé l'embouts de Joint Brosse CV, les profilés OS 30 peuvent être appliqués normalement.

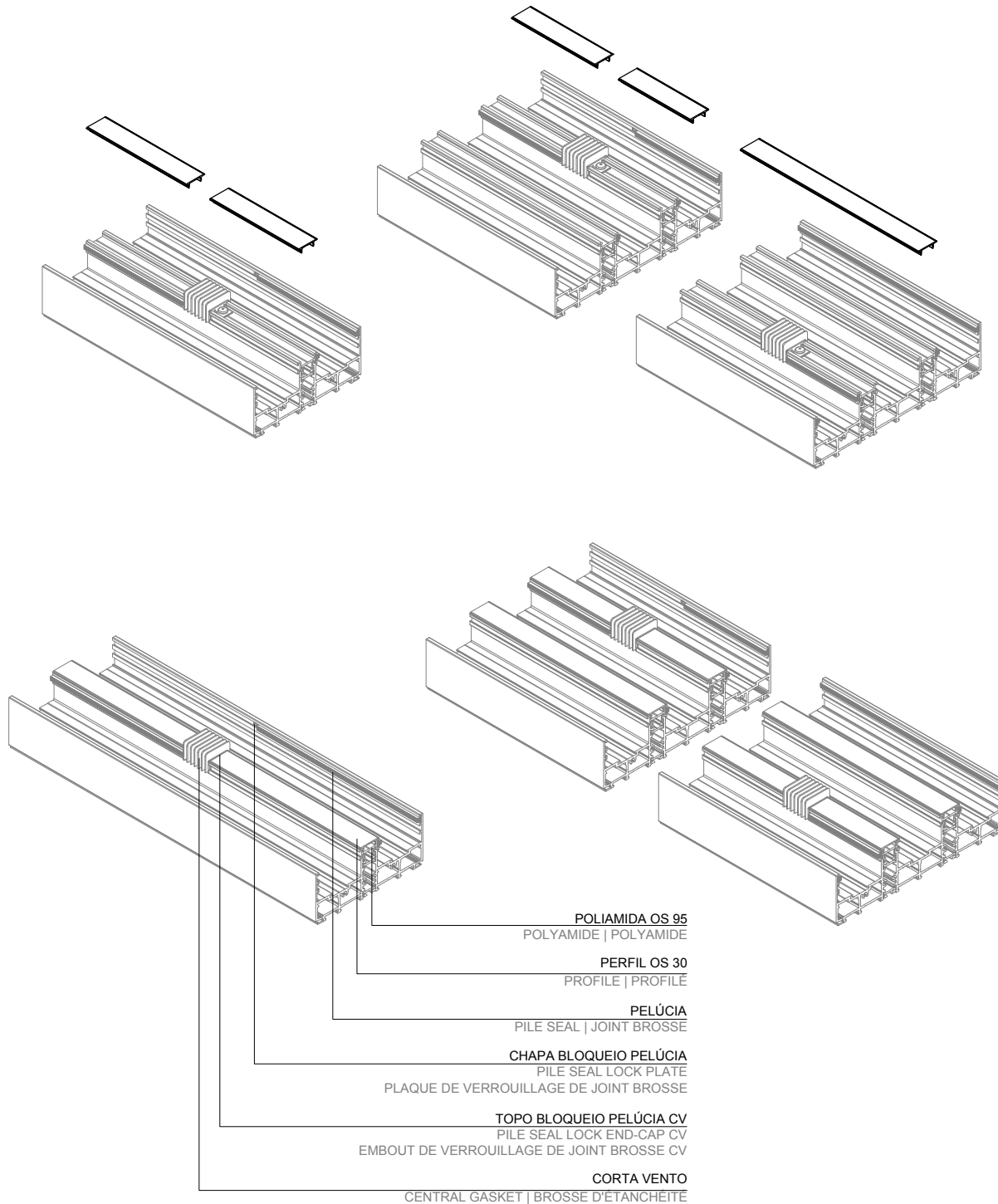

APLICAÇÃO DA PEÇA ANTI-LEVANTAMENTO OS
OS ANTI-LIFT ACCESSORY ASSEMBLY
ASSEMBLAGE DE L'ACCESSOIRE DE ANTI-LEVAGE

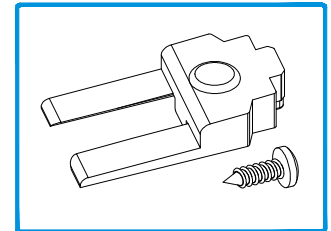

215078 PEÇA ANTI-LEVANTAMENTO OS

1. EXTREMIDADE SUPERIOR DO CAIXILHO
FRAME'S UPPER EDGE | EXTRÊMITÉ SUPÉRIEUR DU CHÂSSIS

PASSO 1 | STEP 1 | ÉTAPE 1

Posicionar a peça anti-levantamento OS no canto superior do caixilho, centrada com a guia superior OS 35 e usá-la para determinar o ponto onde se deve abrir rosca no esquadro (utilizar uma broca de 3mm).

Position the OS anti-lift part in the upper corner of the frame, centered with the OS 35 top guide and use it to determine the point where the blocking bracket should be threaded (use a 3mm drill).

Placez la pièce anti-soulèvement OS dans l'angle supérieur du cadre, centrée avec la guide supérieur OS 35 et utilisez-la pour déterminer le place où fileter l'équerre (utilisez un foret de 3 mm).

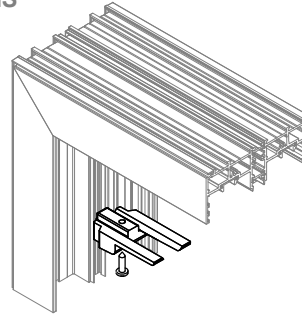

PASSO 2 | STEP 2 | ÉTAPE 2

Aparafusar a peça diretamente ao caixilho (ter em atenção que o parafuso irá roscar no esquadro).

Screw the part directly into the frame (note that the screw will thread into the blocking bracket).

Vissez la pièce directement dans le cadre (notez que la Vis va se Visser dans l'équerre).

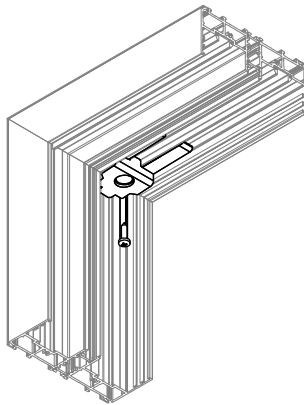

PASSO 3 | STEP 3 | ÉTAPE 3

Colocar o tapa-furos para ocultar o parafuso.

Insert the hole-cover to hide the screw.

Insérez le couvercle du trou pour cacher le Vis.

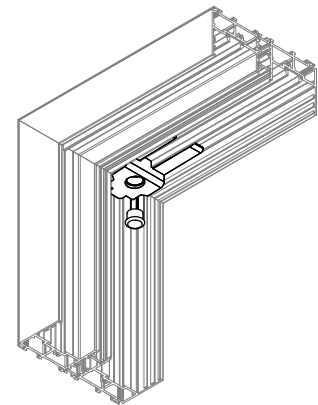

PASSO 4 | STEP 4 | ÉTAPE 4

Repetir os passos anteriores na outra extremidade superior do caixilho.

Repeat the previous steps on the other upper edge of the frame.

Répétez les étapes précédentes à l'autre extrémité supérieure du cadre.

2. ZONA DE CANTO
FRAME'S CORNER | ANGLE DU CHÂSSIS

PASSO 1 | STEP 1 | ÉTAPE 1

Depois de aplicar o topo superior do perfil OS de canto, posicionar a peça anti-levantamento OS no lado da folha móvel, centrada com a guia superior OS 35.

After applying the top end-cap of the OS corner profile, position the OS anti-lift part on the movable leaf side, centered with the OS 35 top guide.

Après avoir appliqué l'embout supérieure du profilé OS d'angle, positionnez la pièce anti-soulèvement sur le côté dormant, centrée avec le guide supérieur OS 35.

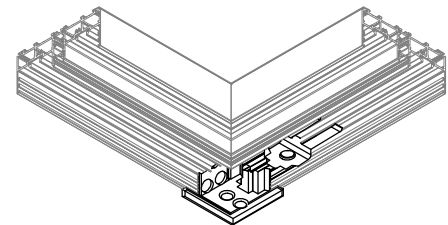

PASSO 2 | STEP 2 | ÉTAPE 2

Aparafusar a peça diretamente ao caixilho.

Screw the part directly to the frame.

Vissez la pièce directement sur le cadre.

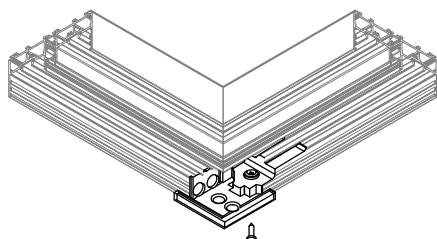

PASSO 3 | STEP 3 | ÉTAPE 3

Colocar o tapa-furos para ocultar o parafuso.

Insert the hole-cover to hide the screw.

Insérez le couvercle du trou pour cacher le Vis.

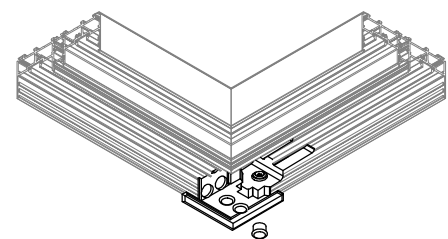

APLICAÇÃO DAS CAPAS SO 60 E SO 63
SO 60 AND SO 63 COVERS APPLICATION
APPLICATION DES COUVERTURES SO 60 ET SO 63

Na aplicação dos perfis SO 60 e SO 63, no perfil 3-Rail SO 12, deverá aplicar-se uma das pelúcias conforme esquema abaixo:

When applying the SO 60 and SO 63 profiles, in the 3-Rail SO 12 profile, one of the pile seals must be applied according to the scheme below:

Lors de l'application des profilés SO 60 et SO 63, dans le profilé 3-Rail SO 12, une des joint brosses doit être appliquée selon le schéma ci-dessous:

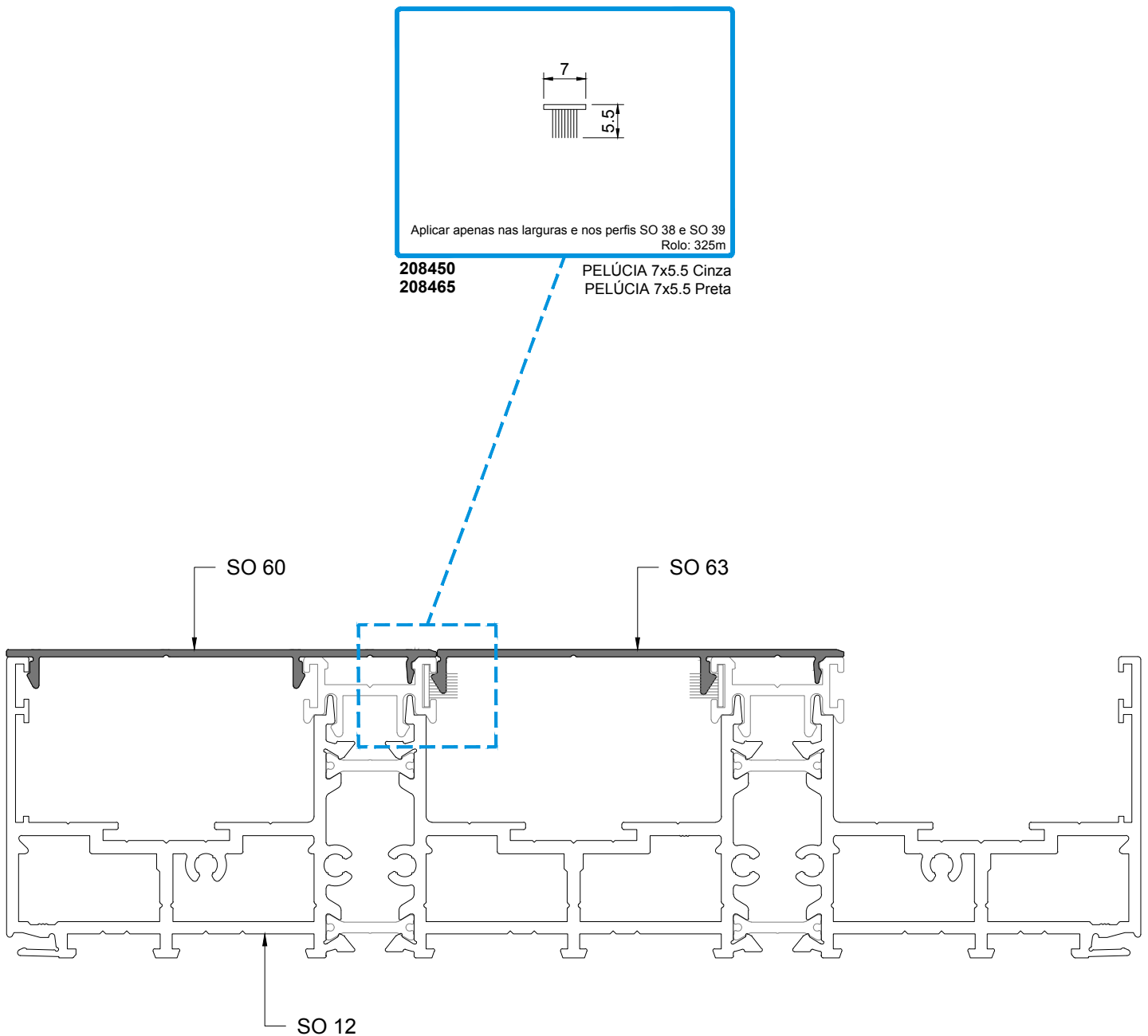

APLICAÇÃO DO CARRINHO OS Nº 5
OS Nº5 ROLLIER BEARING APPLICATION
APPLICATION DU ROULEAU Nº 5

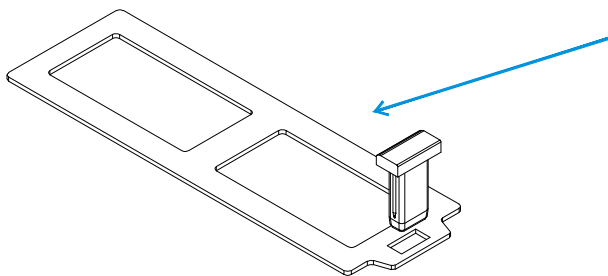
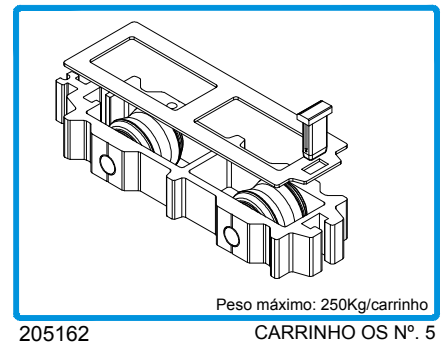

Só se aplica o calço caso seja necessário proceder à afinação.

The shim is only applied if window regulation is necessary.

La cale est appliquée uniquement si la réglage de la fenêtre est nécessaire.

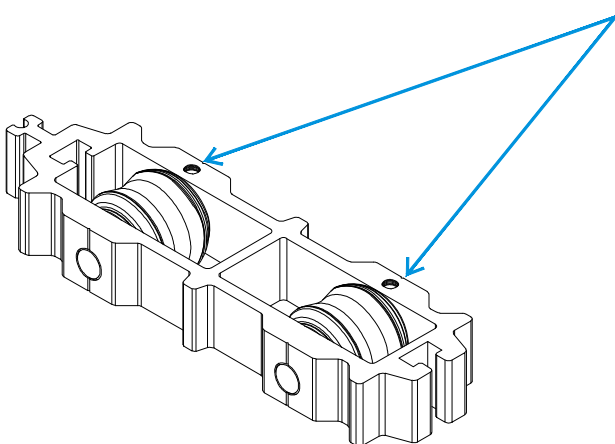

Os Carrinhos OS Nº5 têm de ser aplicados com os furos virados para cima.
A colocação dos Carrinhos OS com os furos voltados para baixo pode provocar o mau deslizamento e, consequentemente, o mau funcionamento da folha.

OS Nº5 Roller Bearings must be applied with the holes facing up.
The placement of the roller bearings with the holes facing down causes bad sliding and consequently leaf malfunctioning.

Rouleaux OS Nº5 doivent être appliqués avec les trous tourné vers le haut.
Le placement des rouleaux avec les trous tourné vers le bas entraîne des problèmes de glissement et, par conséquent, un mauvais fonctionnement du vantail.

APLICAÇÃO CALÇO FIXO OS-DOUBLE - Janela de correr de 2 folhas + fixo em canto de 90°

OS-DOUBLE FIXED SHIM APPLICATION - 2 Leaves sliding window + fixed in 90° corner

APPLICATION DE CALE FIXE OS-DOUBLE - Fenêtre coulissant à 2 vantaux + cadre fixe en angle 90°

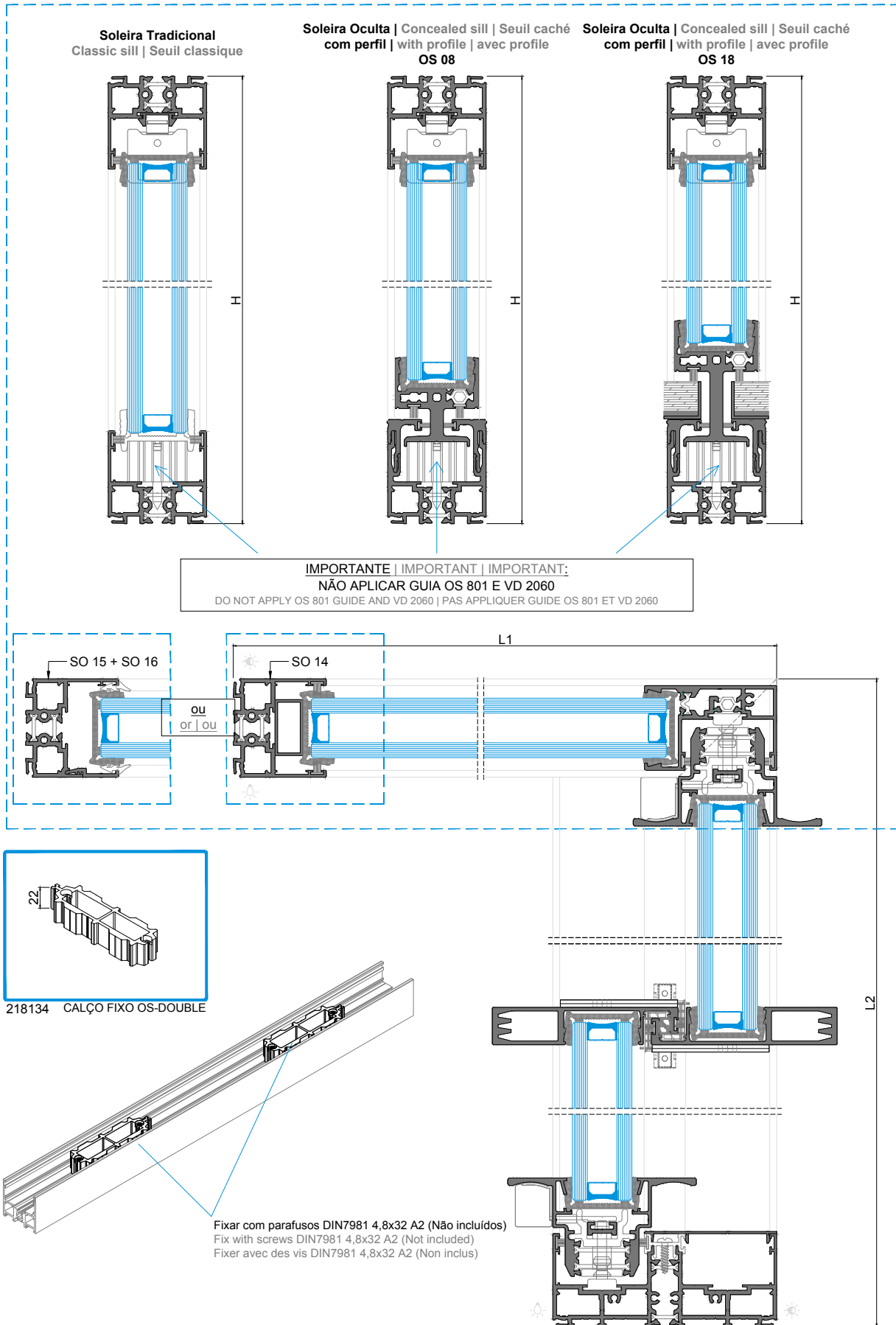

APLICAÇÃO DOS TOPOS LATERAIS
LATERAL END-CAPS APPLICATION
APPLICATION D'EMBOUITS LATÉRAUX

Para os perfis | For profiles | Pour profilés
SO 64 / SO 65 / SO 66

Para o perfil | For profile | Pour profilé
SO 03

ZONA SUPERIOR
TOP FRAME | ZONE SUPERIEURE

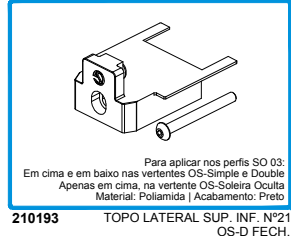
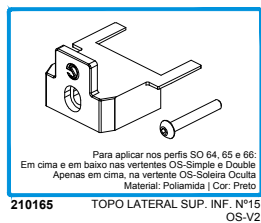

SOL. TRADICIONAL
CLASSIC SILL | SEUIL CLASSIQUE

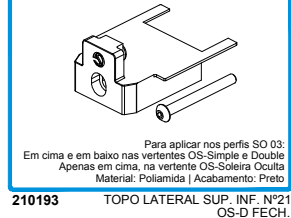
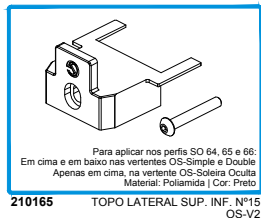

ZONA INFERIOR
BOTTOM FRAME | ZONE INFÉRIEURE

SOL. OCULTA
CONCEALED SILL | SEUIL CACHÉ
OS 08

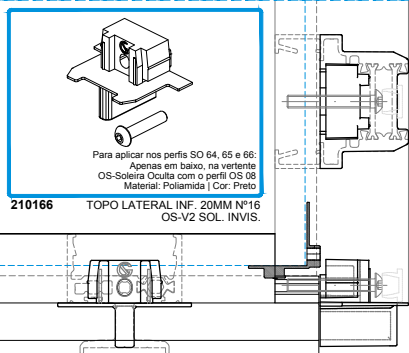

ZONA INFERIOR
BOTTOM FRAME | ZONE INFÉRIEURE

SOL. OCULTA
CONCEALED SILL | SEUIL CACHÉ
OS 08

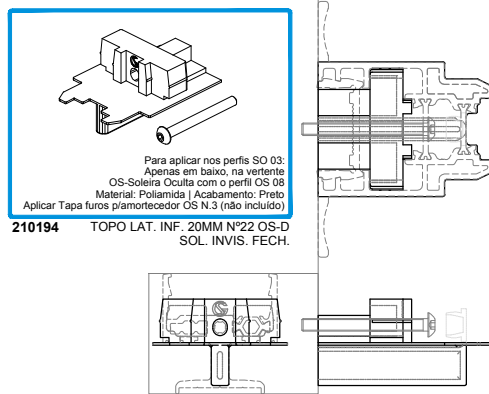

SOL. OCULTA
CONCEALED SILL | SEUIL CACHÉ
OS 18

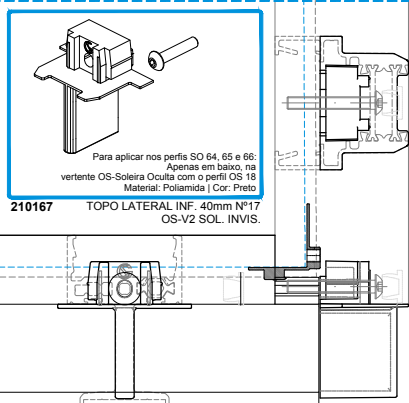

SOL. OCULTA
CONCEALED SILL | SEUIL CACHÉ
OS 18

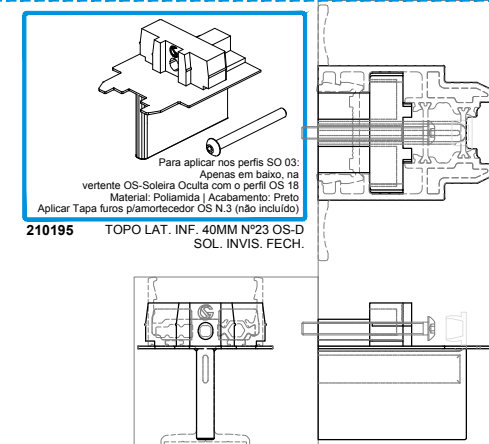

APLICAÇÃO DOS TOPOS LATERAIS - SOLUÇÃO SOLEIRA OCULTA COM OS 08 E COM OS 18

LATERAL END-CAPS APPLICATION - CONCEALED SILL WITH OS 08 AND WITH OS 18

APPLICATION D'EMBOUITS LATÉRAUX - SEUIL CACHÉ AVEC OS 08 ET AVEC OS 18

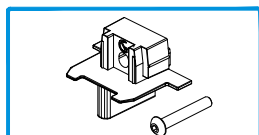

Para aplicar nos perfis SO 64, 65 e 66:
Apenas em baixo, na vertente OS-Soleira Oculta com o perfil OS 08
Material: Poliamida | Cor: Preto
Aplicar Tapa furos p/amortecedor OS N.3 (não incluído)

210166 TOPO LATERAL INF. 20MM N°16 OS-V2 SOL. INVIS.

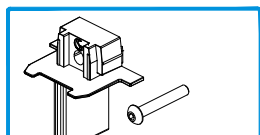

Para aplicar nos perfis SO 64, 65 e 66:
Apenas em baixo, na vertente OS-Soleira Oculta com o perfil OS 18
Material: Poliamida | Cor: Preto
Aplicar Tapa furos p/amortecedor OS N.3 (não incluído)

210167 TOPO LATERAL INF. 40mm N°17 OS-V2 SOL. INVIS.

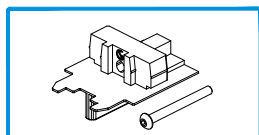

Para aplicar nos perfis SO 03:
Apenas em baixo, na vertente OS-Soleira Oculta com o perfil OS 08
Material: Poliamida | Acabamento: Preto
Aplicar Tapa furos p/amortecedor OS N.3 (não incluído)

210194 TOPO LAT. INF. 20MM N°22 OS-D SOL. INVIS. FECH.

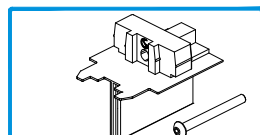

Para aplicar nos perfis SO 03:
Apenas em baixo, na vertente OS-Soleira Oculta com o perfil OS 18
Material: Poliamida | Acabamento: Preto
Aplicar Tapa furos p/amortecedor OS N.3 (não incluído)

210195 TOPO LAT. INF. 40MM N°23 OS-D SOL. INVIS. FECH.

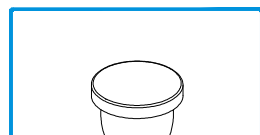

Material: SEBS | Acabamento: Preto

210604 TAPA FUROS P/ AMORTECEDOR OS N.3

SOL. OCULTA - OS 08
CONCEALED SILL | SEUIL CACHÉ

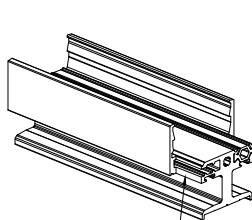
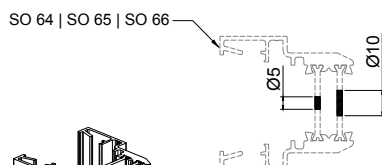

SO 08
Corte mecanizado
Mechanised cutting
Coupe mécanisée

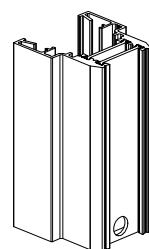

Ref. 210166
(PF DIN7380 M5x35
incluído | included |
inclus)
Ref.210604

SOL. OCULTA - OS 18
CONCEALED SILL | SEUIL CACHÉ

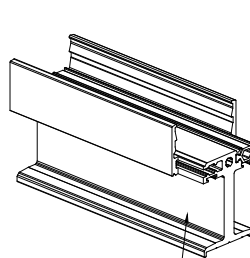
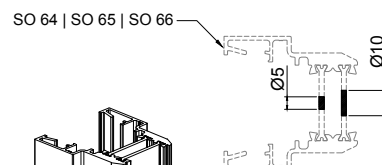

SO 18
Corte mecanizado
Mechanised cutting
Coupe mécanisée

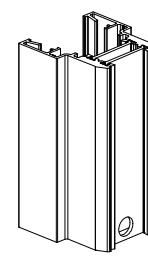

Ref. 210167
(PF DIN7380 M5x35
incluído | included |
inclus)
Ref.210604

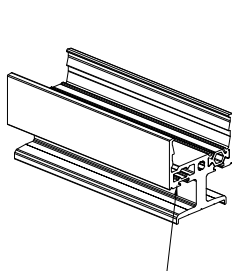
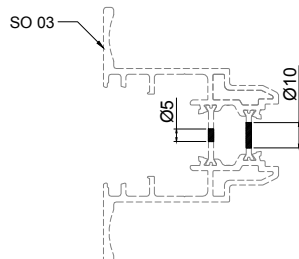

SO 08
Corte 90°
90° cutting
Coupe à 90°

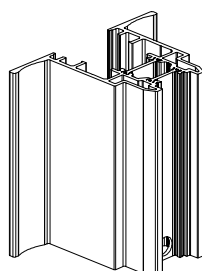

Ref. 210194
(PF DIN7380 M5x50
incluído | included |
inclus)
Ref.210604

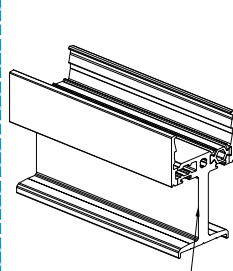
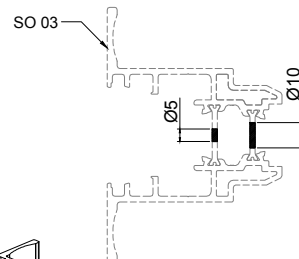

SO 18
Corte 90°
90° cutting
Coupe à 90°

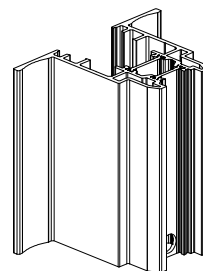

Ref. 210194
(PF DIN7380 M5x50
incluído | included |
inclus)
Ref.210604

APLICAÇÃO DE TOPOS NO PERFIL OS 27
OS 27 PROFILE END-CAPS APPLICATION
APPLICATION D'EMBOUTS POUR PROFILÉ OS 27

Para os perfis | For profiles | Pour profilés
SO 64 / SO 65 / SO 66

Para o perfil | For profile | Pour profilé: OS 27

ZONA SUPERIOR TOP FRAME ZONE SUPÉRIEURE	<p>Paraf. DIN7991 M5x45 (Não incluído no kit) Screw (Not included) Vis (Non inclus)</p> <p>Para aplicar nos perfis SO 64, 65 e 66: Em cima e em baixo nas vertentes OS-Simple e Double Apenas em cima, na vertente OS-Soleira Oculta Material: Poliamida Cor: Preto</p> <p>210165 TOPO LATERAL SUP. INF. Nº15 OS-V2</p>	<p>Paraf. DIN7991 M5x10 (Não incluído no kit) Screw (Not included) Vis (Non inclus)</p> <p>Topo sup/inf para OS 12 72 82 Upper/lower end-cap for OS 12 72 82 Embout sup/inf pour OS 12 72 82</p> <p>Topo sup/inf para OS 27 Upper/lower end-cap for OS 27 Embout sup/inf pour OS 27</p> <p>Aplicar quando se utiliza o perfil OS 27 Aplicar em cima e em baixo na soleira normal Aplicar apenas em cima na soleira oculta</p> <p>212124 CONJUNTO TOPOS PARA OS 27</p>
	<p>Paraf. DIN7991 M5x45 (Não incluído no kit) Screw (Not included) Vis (Non inclus)</p> <p>Para aplicar nos perfis SO 64, 65 e 66: Em cima e em baixo nas vertentes OS-Simple e Double Apenas em cima, na vertente OS-Soleira Oculta Material: Poliamida Cor: Preto</p> <p>210165 TOPO LATERAL SUP. INF. Nº15 OS-V2</p>	<p>Paraf. DIN7991 M5x10 (Não incluído no kit) Screw (Not included) Vis (Non inclus)</p> <p>Topo sup/inf para OS 12 72 82 Upper/lower end-cap for OS 12 72 82 Embout sup/inf pour OS 12 72 82</p> <p>Topo sup/inf para OS 27 Upper/lower end-cap for OS 27 Embout sup/inf pour OS 27</p> <p>Aplicar quando se utiliza o perfil OS 27 Aplicar em cima e em baixo na soleira normal Aplicar apenas em cima na soleira oculta</p> <p>212124 CONJUNTO TOPOS PARA OS 27</p>
ZONA INFERIOR BOTTOM FRAME ZONE INFÉRIEURE	<p>Paraf. DIN7991 M5x45 (Não incluído no kit) Screw (Not included) Vis (Non inclus)</p> <p>Para aplicar nos perfis SO 64, 65 e 66: Em cima e em baixo nas vertentes OS-Simple e Double Apenas em cima, na vertente OS-Soleira Oculta Material: Poliamida Cor: Preto</p> <p>210165 TOPO LATERAL SUP. INF. Nº15 OS-V2</p>	<p>Paraf. DIN7991 M5x10 (Não incluído no kit) Screw (Not included) Vis (Non inclus)</p> <p>Topo sup/inf para OS 12 72 82 Upper/lower end-cap for OS 12 72 82 Embout sup/inf pour OS 12 72 82</p> <p>Topo sup/inf para OS 27 Upper/lower end-cap for OS 27 Embout sup/inf pour OS 27</p> <p>Aplicar quando se utiliza o perfil OS 27 Aplicar em cima e em baixo na soleira normal Aplicar apenas em cima na soleira oculta</p> <p>212124 CONJUNTO TOPOS PARA OS 27</p>
	<p>Para aplicar nos perfis SO 64, 65 e 66: Apenas em baixo, na vertente OS-Soleira Oculta com o perfil OS 08 Material: Poliamida Cor: Preto</p> <p>210166 TOPO LATERAL INF. 20MM Nº16 OS-V2 SOL. INVIS.</p>	<p>210233 TOPO INF. SOL. OCULTA OS 27</p> <p>Importante Important Importante: Para obter o Topo, consultar o Dep. Técnico To obtain the End-cap, consult Technical Dep. Pour l'Embout, consulter le Dép. Technique</p>
	<p>Para aplicar nos perfis SO 64, 65 e 66: Apenas em baixo, na vertente OS-Soleira Oculta com o perfil OS 18 Material: Poliamida Cor: Preto</p> <p>210167 TOPO LATERAL INF. 40mm Nº17 OS-V2 SOL. INVIS.</p>	<p>210233 TOPO INF. SOL. OCULTA OS 27</p> <p>Importante Important Importante: Para obter o Topo, consultar o Dep. Técnico To obtain the End-cap, consult Technical Dep. Pour l'Embout, consulter le Dép. Technique</p>

PORMENORES DE APLICAÇÃO E MONTAGEM DO CONJUNTO DE TOPOS OS 27

OS 27 END-CAP KIT APPLICATION AND ASSEMBLY DETAILS

DÉTAILS D'APPLICATION ET D'ASSEMBLAGE DU KIT D'EMBOUTS OS 27

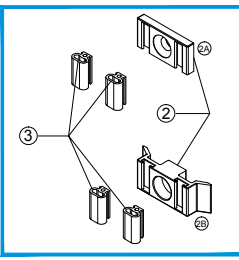

- ① Carrinho/guia superior OS
Upper-guide roller bearing OS
Rouleau-guide supérieur OS
- ② Conjunto Topos para OS 27
OS 27 end-cap kit
Kit d'embouts pour OS 27
2A-Topo superior - para SO 64 | 65 | 66
Upper end-cap - for SO 64 | 65 | 66
Embout supérieur - pour SO 64 | 65 | 66
2B-Topo superior - para OS 27
Upper end-cap - for OS 27
Embout supérieur - pour OS 27
- ③ VD 2051 - Não incluído no kit
Not included in kit - consider apart
Non inclus dans le kit

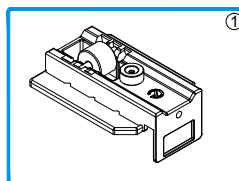

205161 CARRINHO-GUIA OS SUPERIOR N°3

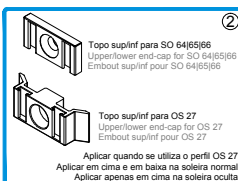

212124 CONJUNTO TOPOS PARA OS 27

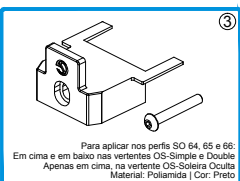

210165 TOPO LATERAL SUP. INF. N°15 OS-V2

NO PERFIL SO 65

ON OSO 65 PROFILE | DANS LE PROFILÉ SO 65

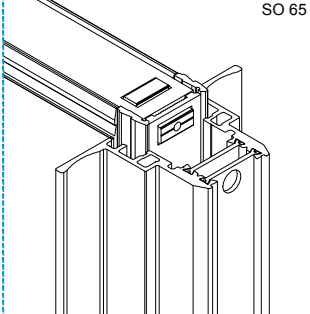

SO 65

- ① Aplicar | Apply | Appliquer:
Carrinho/guia superior OS N°3
Upper-guide roller bearing OS N°3
Rouleau-guide supérieur OS N°3
- ② Aplicar | Apply | Appliquer:
Topo lateral Sup/Inf OS N°15 OS-V2
Upper/lower lateral end-cap OS N°15-V2
Embout latérale sup/inf OS N°15-V2
- ③ Aplicar | Apply | Appliquer:
Conjunto Topos para OS 27
OS 27 end-cap kit
Kit d'embouts pour OS 27
2A-Topo superior - para SO 64 | 65 | 66
Upper end-cap - for SO 64 | 65 | 66
Embout supérieur - pour SO 64 | 65 | 66
- ④ Aplicar | Apply | Appliquer:
Parafuso DIN 7991 M5x45 (Não incluído no kit)
Screw DIN 7991 M5x45 (Not included in kit)
Vis DIN 7991 M5x45 (Non inclus dans le kit)

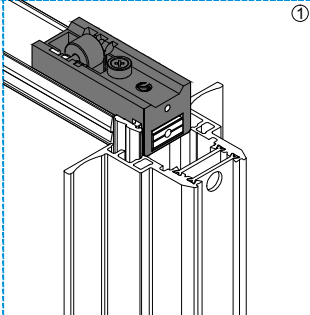
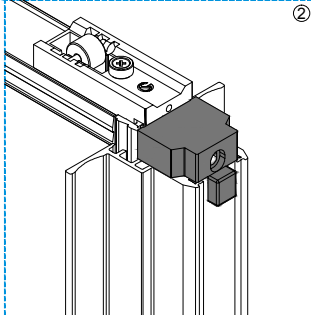
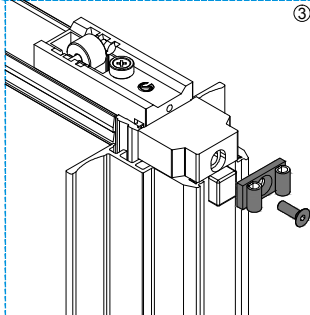
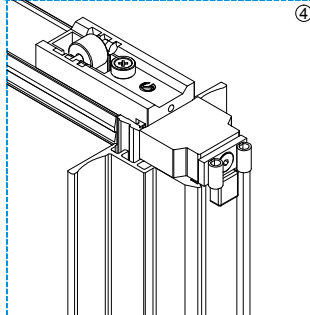
NO PERFIL OS 27

ON OS 27 PROFILE | DANS LE PROFILÉ OS 27

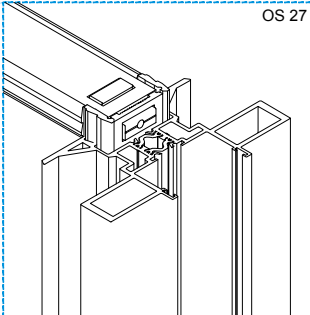

OS 27

- ① Aplicar | Apply | Appliquer:
Carrinho/guia superior OS N°3
Upper-guide roller bearing OS N°3
Rouleau-guide supérieur OS N°3
- ② Aplicar | Apply | Appliquer:
Conjunto Topos para OS 27
OS 27 end-cap kit
Kit d'embouts pour OS 27
2B-Topo superior - para OS 27
Upper end-cap - for OS 27
Embout supérieur - pour OS 27
- ③ Aplicar | Apply | Appliquer:
Parafuso DIN 7991 M5x10 (Não incluído no kit)
Screw DIN 7991 M5x10 (Not included in kit)
Vis DIN 7991 M5x10 (Non inclus dans le kit)

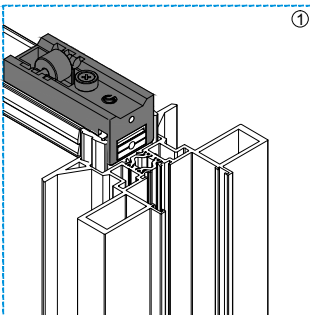
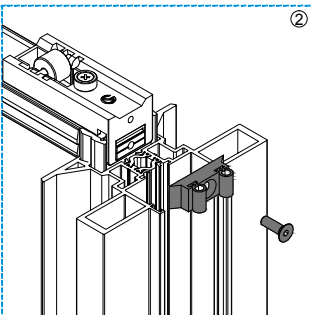
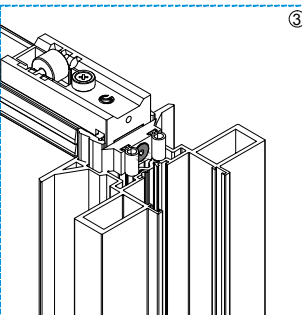



APLICAÇÃO DOS TOPOS CENTRAIS
CENTRAL END-CAPS APPLICATION
APPLICATION D'EMBOUTS CENTRAUX

Para os perfis | For profiles | Pour profilés
OS 11 / OS 51 / OS 61

Para os perfis | For profiles | Pour profilés
OS 17 / OS 67

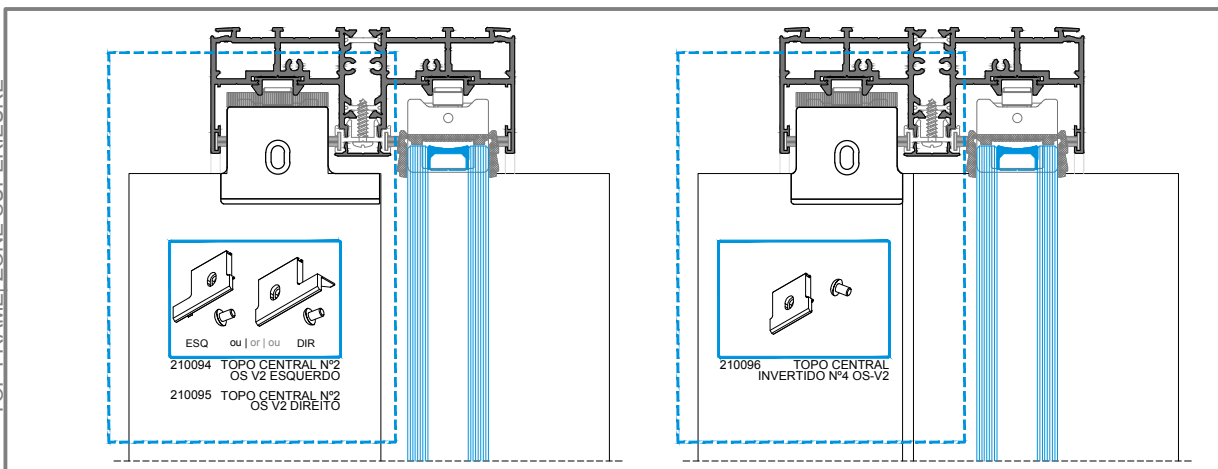
ZONA SUPERIOR
TOP FRAME | ZONE SUPÉRIEURE



SOLEIRA TRADICIONAL
CLASSIC SILL | SEUIL CLASSIQUE

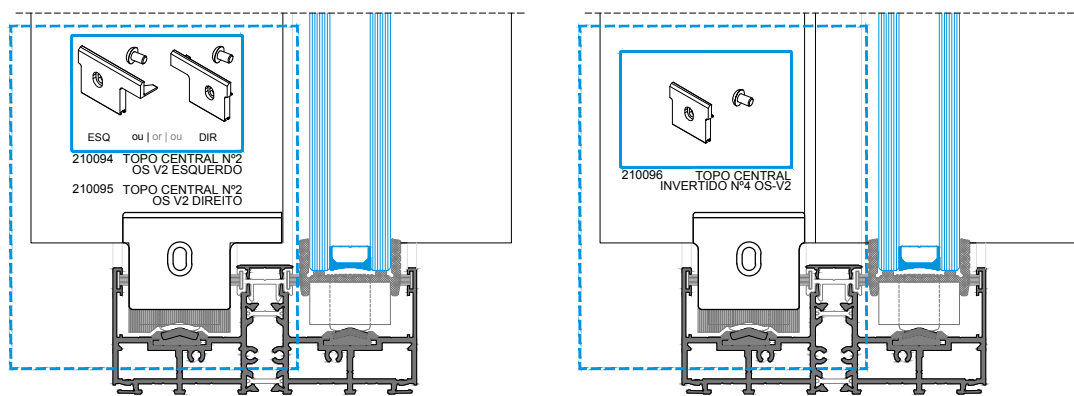

ZONA INFERIOR
BOTTOM FRAME | ZONE INFÉRIEURE
SOLEIRA OCULTA
CONCEALED SILL | SEUIL CACHÉ OS 08

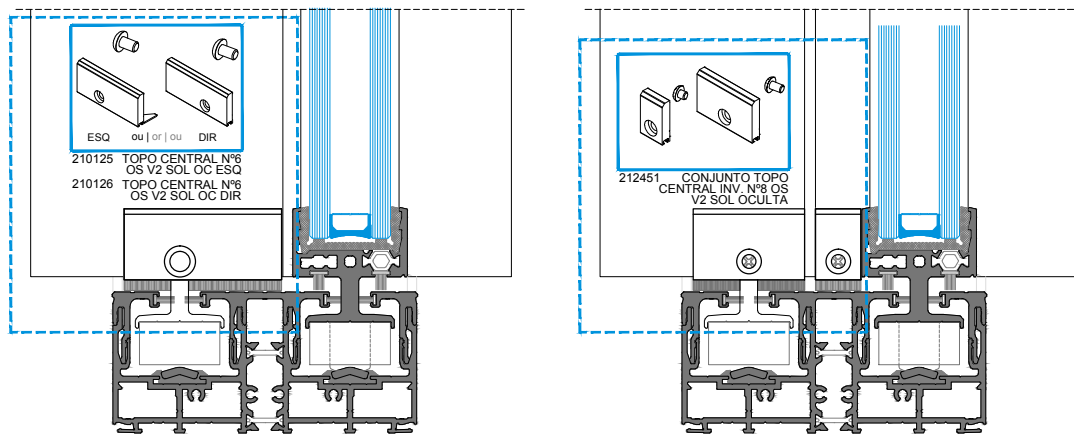

SOLEIRA OCULTA
CONCEALED SILL | SEUIL CACHÉ OS 18

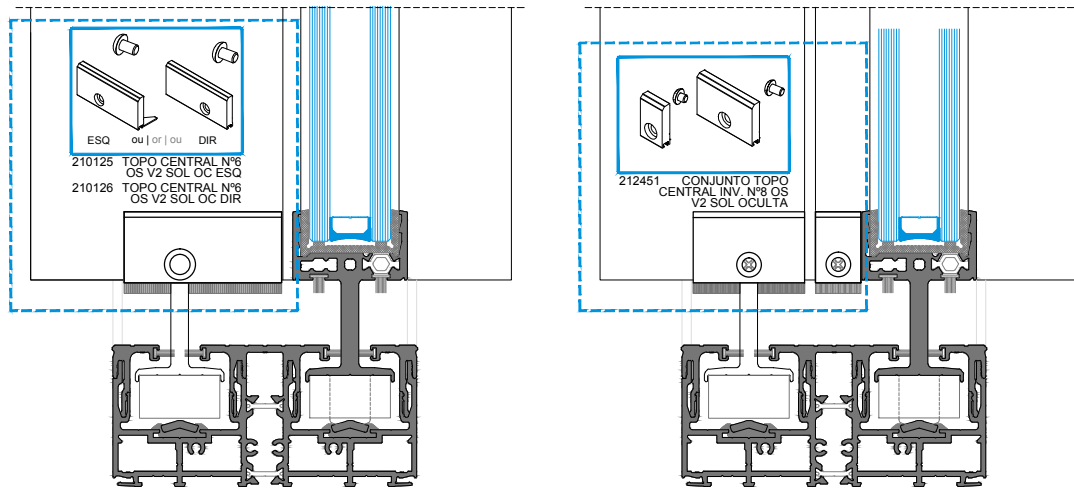

APLICAÇÃO DOS TOPOS CENTRAIS
CENTRAL END-CAPS APPLICATION
APPLICATION D'EMBOUTS CENTRAUX

- **PERFIS OS 11 / OS 51 / OS 61**
PROFILES OS 11 / OS 51 / OS 61
PROFILÉS OS 11 / OS 51 / OS 61

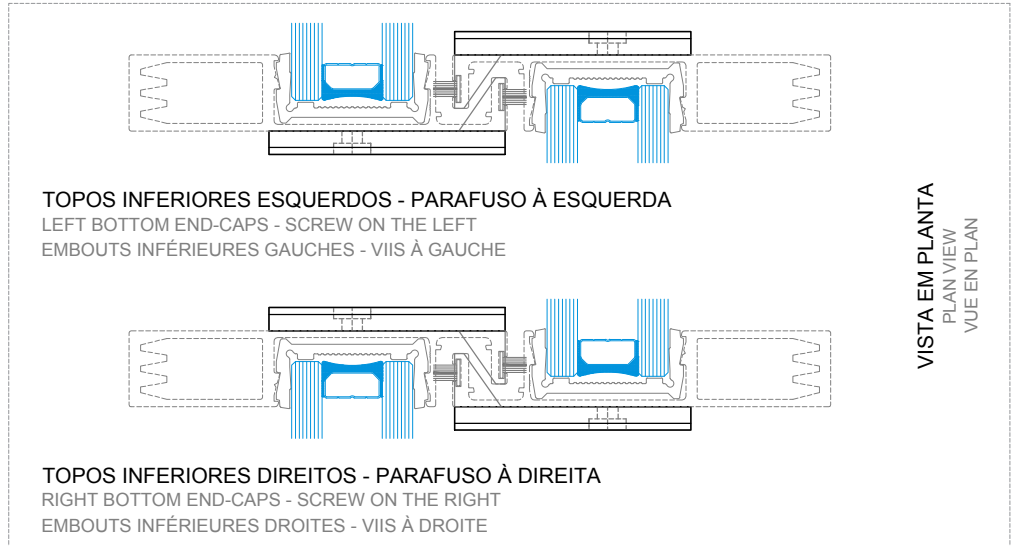
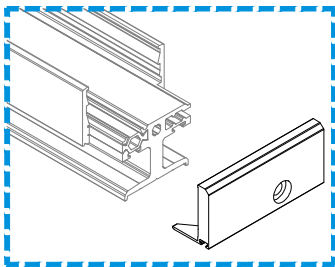
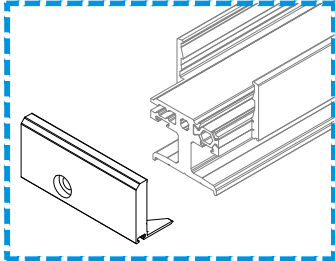
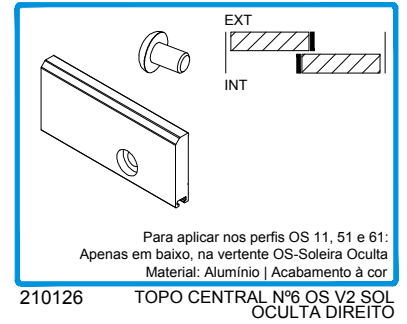
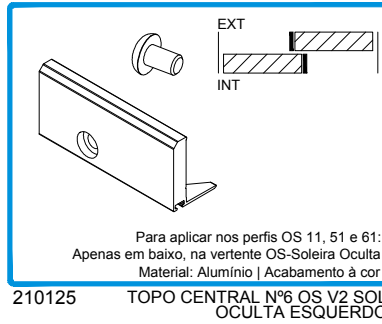

Os topos superiores serão sempre do lado contrário dos inferiores.
The upper end-caps will always be on the opposite side of the bottom ones.
Les embouts supérieurs seront toujours du côté opposé des inférieurs.

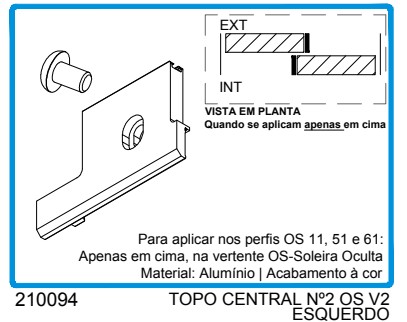
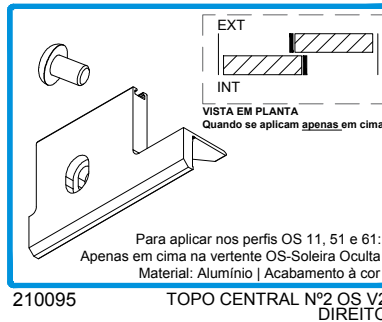

- **PERFIS OS 17 / OS 67**
PROFILES OS 17 / OS 67
PROFILÉS OS 17 / OS 67

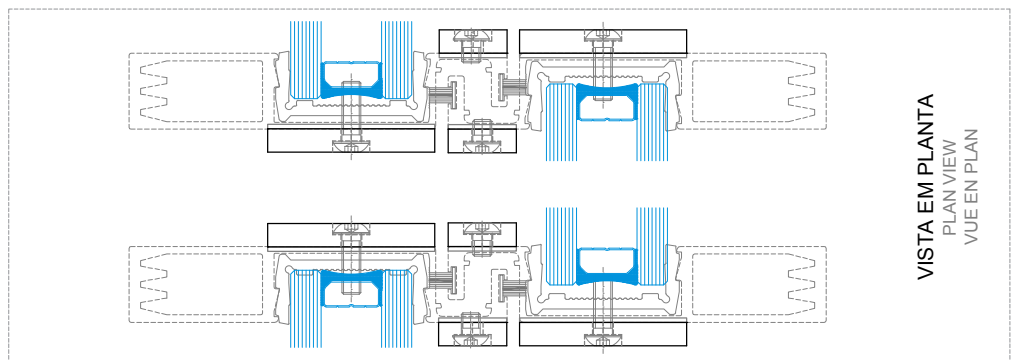
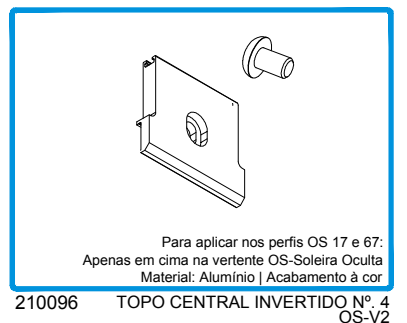
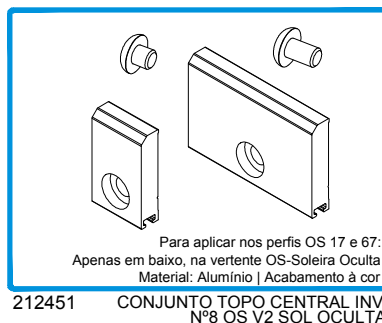
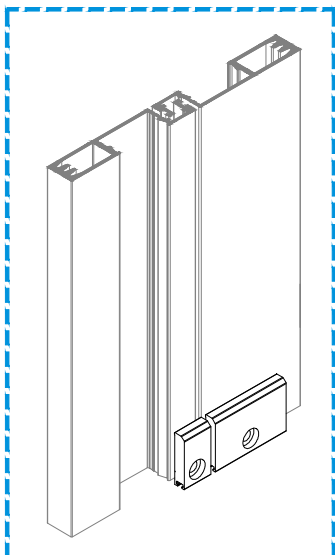

APLICAÇÃO DE TOPOS NOS PERFIS OS 51 E OS 61
END-CAPS APPLICATION ON OS 51 AND OS 61 PROFILES
APPLICATION DES EMBOUTS DANS LES PROFILÉS OS 51 ET OS 61

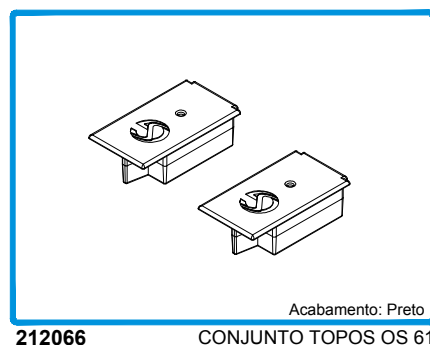
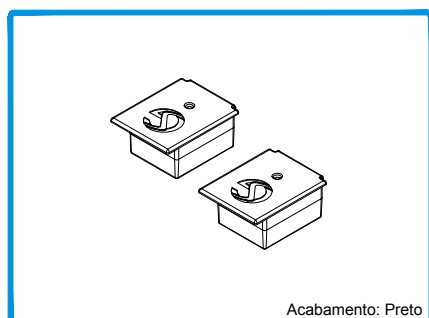

PORMENOR DE MONTAGEM
ASSEMBLY DETAIL | DÉTAIL D'ASSEMBLAGE

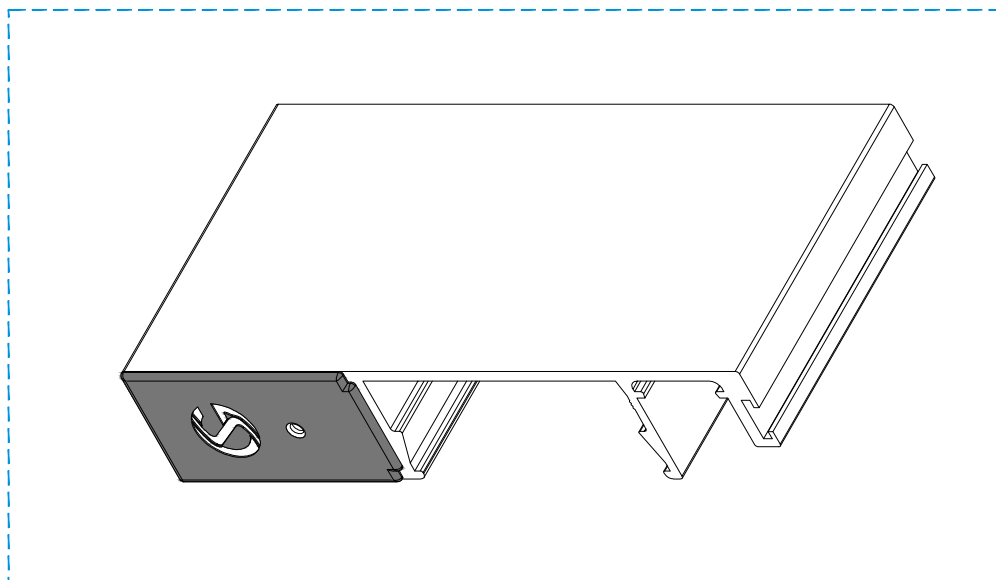

APLICAÇÃO DO TOPO SO 63
SO 63 END-CAP APPLICATION
APPLICATION D'EMBOUT SO 63

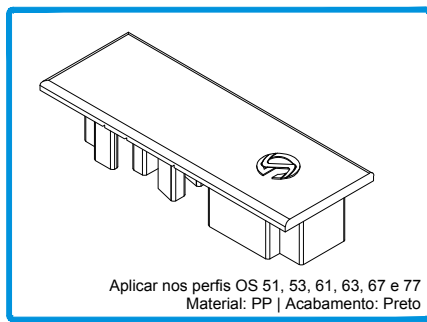

Aplicar nos perfis OS 51, 53, 61, 63, 67 e 77
Material: PP | Acabamento: Preto

210109

TOPO OS 63 PRT

Cortar o topo na posição indicada, conforme perfil onde é aplicado:

Cut the top in the indicated position, according to the profile where it is be applied:

Couper l'embout dans la position indiquée, selon le profilé où il est appliqué:

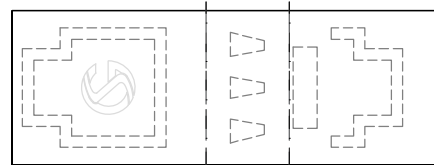

① ②

Possível alternativa ao Topo existente:
Possible alternative to the existing End-cap
Alternative possible au Embout existant

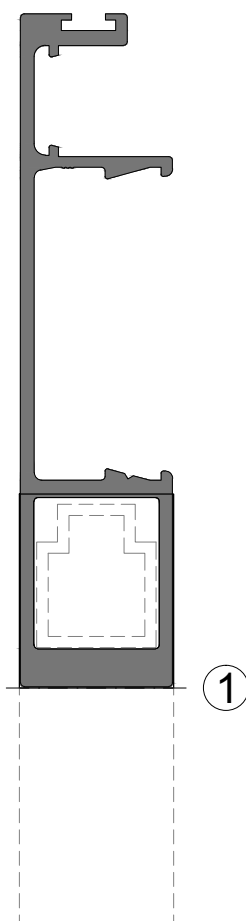

OS 51

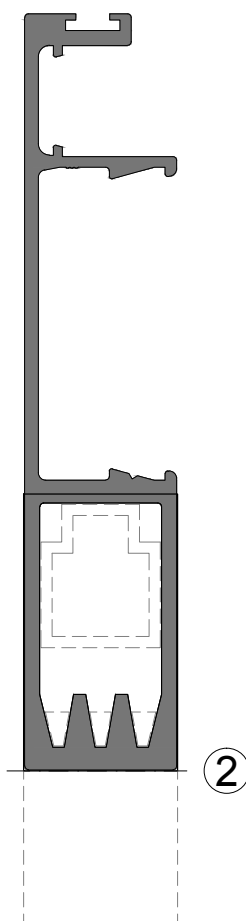

OS 61

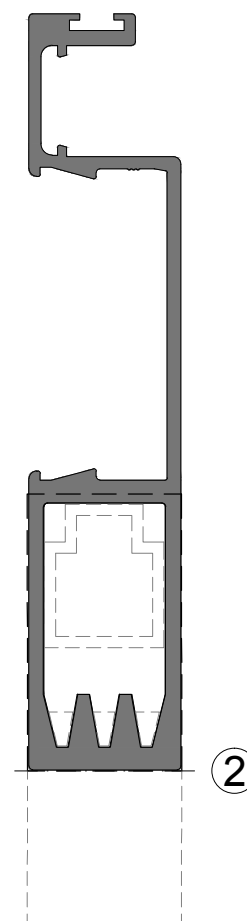

OS 67

APLICAÇÃO DOS TOPOS PARA O PERFIL SO 43
SO 43 PROFILE END-CAPS APPLICATION
APPLICATION DES EMBOUTS POUR LE PROFILÉS SO 43

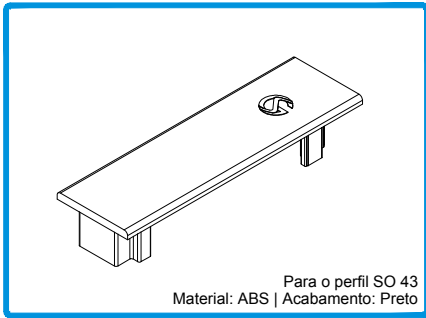

Para o perfil SO 43
Material: ABS | Acabamento: Preto

210196

TOPO SO 43 PRT

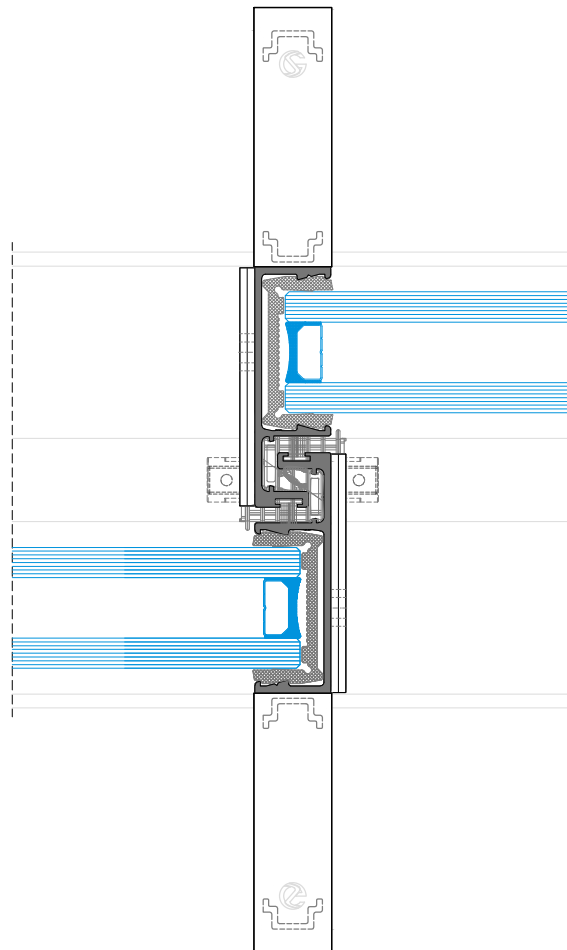
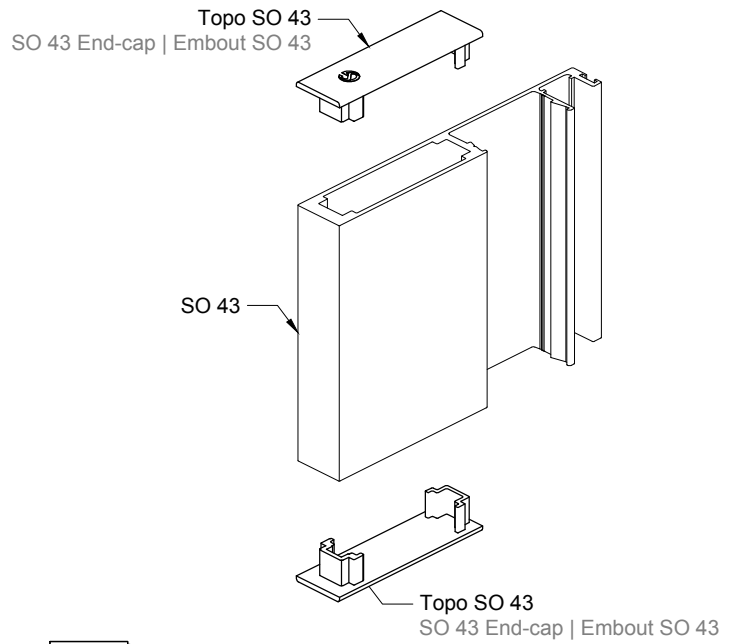

MONTAGEM DOS PERFIS CENTRAIS SO 38 E SO 39 - SOLEIRA TRADICIONAL

CENTRAL PROFILES SO 38 AND SO 39 ASSEMBLY - CLASSIC SILL

ASSEMBLAGE DES PROFILÉS CENTRAUX SO 38 ET SO 39 - SEUIL CLASSIQUE

Para os perfis | For profiles | Pour profilés
SO 38 e | and | et SO 39

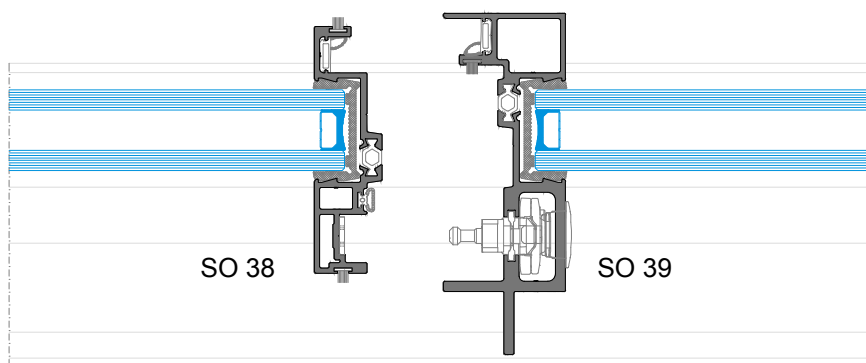

ZONA SUPERIOR | ZONE SUPÉRIEURE
TOP FRAME

PERFIS MALHETADOS | MACHINED PROFILES | PROFILÉS MÉCANISÉS

IMPORTANTE | IMPORTANT | IMPORTANT:
Na encomenda do vidro, pedir este acessório.
When ordering the glass, ask for this accessory.
Lors de la commande du verre, demandez cet accessoire.

IMPORTANTE | IMPORTANT | IMPORTANT:
Na encomenda do vidro, pedir este acessório.
When ordering the glass, ask for this accessory.
Lors de la commande du verre, demandez cet accessoire.

ZONA INFERIOR | ZONE INFÉRIEURE
BOTTOM FRAME

SOL. TRADICIONAL (OPÇÃO COM FURO)
CLASSIC SILL (WITH HOLE OPTION)
SEUIL CLASSIQUE (OPTION AVEC TROU)

PERFIS MALHETADOS | MACHINED PROFILES | PROFILÉS MÉCANISÉS

IMPORTANTE | IMPORTANT | IMPORTANT:
Na encomenda do vidro, pedir este acessório.
When ordering the glass, ask for this accessory.
Lors de la commande du verre, demandez cet accessoire.

IMPORTANTE | IMPORTANT | IMPORTANT:
Na encomenda do vidro, pedir este acessório.
When ordering the glass, ask for this accessory.
Lors de la commande du verre, demandez cet accessoire.

SOL. TRADICIONAL (OPÇÃO SEM FURO)
CLASSIC SILL (WITHOUT HOLE OPTION)
SEUIL CLASSIQUE (OPTION SANS TROU)

PERFIS MALHETADOS | MACHINED PROFILES | PROFILÉS MÉCANISÉS

IMPORTANTE | IMPORTANT | IMPORTANT:
Na encomenda do vidro, pedir este acessório.
When ordering the glass, ask for this accessory.
Lors de la commande du verre, demandez cet accessoire.

IMPORTANTE | IMPORTANT | IMPORTANT:
Na encomenda do vidro, pedir este acessório.
When ordering the glass, ask for this accessory.
Lors de la commande du verre, demandez cet accessoire.

MONTAGEM DOS PERFIS CENTRAIS SO 38 E SO 39 - SOLEIRA OCULTA
CENTRAL PROFILES SO 38 AND SO 39 ASSEMBLY - CONCEALED SILL
ASSEMBLAGE DES PROFILÉS CENTRAUX SO 38 ET SO 39 - SEUIL CACHÉE

Para os perfis | For profiles | Pour profilés
SO 38 e | and | et SO 39

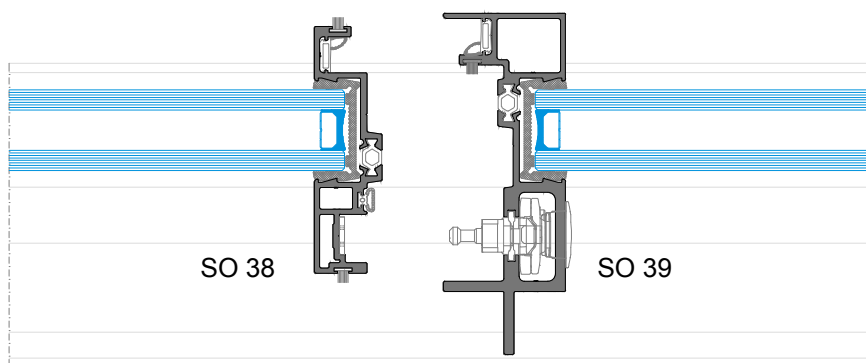

ZONA SUPERIOR
TOP FRAME | ZONE SUPÉRIEURE

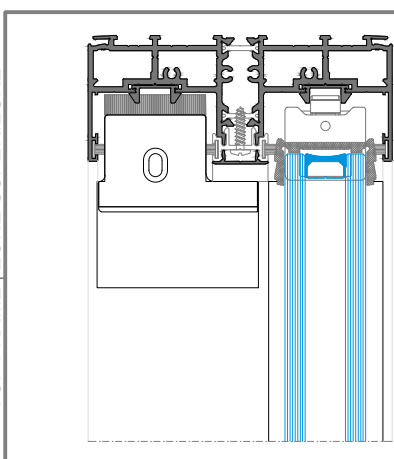

PERFIS MALHETADOS | MACHINED PROFILES | PROFILÉS MÉCANISÉS

IMPORTANTE | IMPORTANT | IMPORTANT:
Na encomenda do vidro, pedir este acessório.
When ordering the glass, ask for this accessory.
Lors de la commande du verre, demandez cet accessoire.

IMPORTANTE | IMPORTANT | IMPORTANT:
Na encomenda do vidro, pedir este acessório.
When ordering the glass, ask for this accessory.
Lors de la commande du verre, demandez cet accessoire.

ZONA INFERIOR
BOTTOM FRAME | ZONE INFÉRIEURE

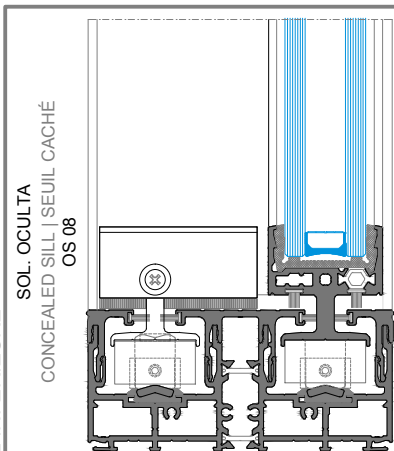

PERFIS CORTE 90° | CUTTING PROFILES 90° | PROFILÉS COUPE 90°

IMPORTANTE | IMPORTANT | IMPORTANT:
Na encomenda do vidro, pedir este acessório.
When ordering the glass, ask for this accessory.
Lors de la commande du verre, demandez cet accessoire.

IMPORTANTE | IMPORTANT | IMPORTANT:
Na encomenda do vidro, pedir este acessório.
When ordering the glass, ask for this accessory.
Lors de la commande du verre, demandez cet accessoire.

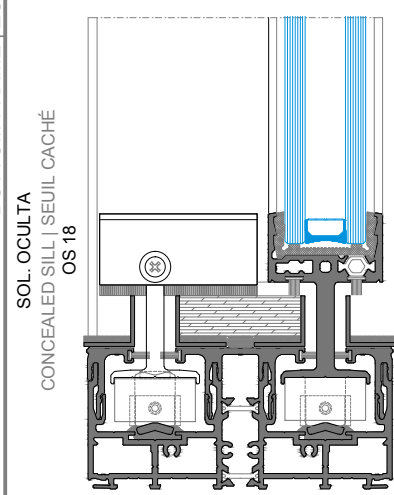

PERFIS CORTE 90° | CUTTING PROFILES 90° | PROFILÉS COUPE 90°

IMPORTANTE | IMPORTANT | IMPORTANT:
Na encomenda do vidro, pedir este acessório.
When ordering the glass, ask for this accessory.
Lors de la commande du verre, demandez cet accessoire.

IMPORTANTE | IMPORTANT | IMPORTANT:
Na encomenda do vidro, pedir este acessório.
When ordering the glass, ask for this accessory.
Lors de la commande du verre, demandez cet accessoire.

MONTAGEM DOS PERFIS CENTRAIS SO 38 E SO 39 - OPÇÃO DE CORTE DOS PERFIS
CENTRAL PROFILES SO 38 AND SO 39 ASSEMBLY - CUTTING OPTION OF THE PROFILES
ASSEMBLAGE DES PROFILÉS CENTRAUX SO 38 ET SO 39 - OPTION DE COUPE DE PROFILÉS

SOLEIRA TRADICIONAL
CLASSIC SILL | SEUIL CLASSIQUE

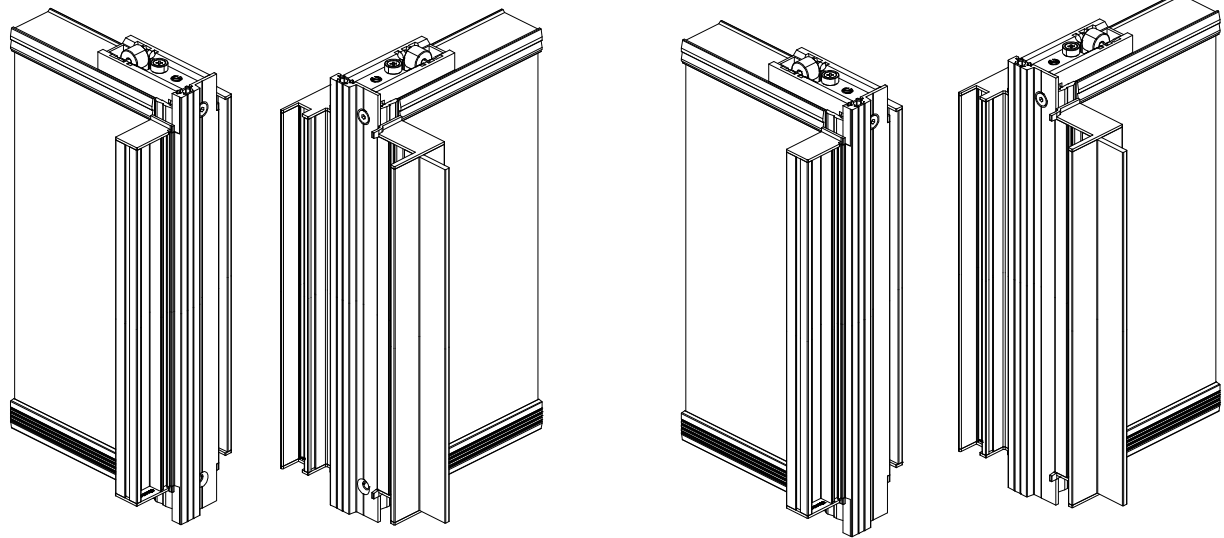

OPÇÃO MALHETE INFERIOR APARAFUSADO
BOTTOM MILLING OPTION SCREWED
OPTION FRAISAGE INFÉRIEUR VISSÉ

OPÇÃO MALHETE INFERIOR SEM FURO
BOTTOM MILLING OPTION WITHOUT HOLE
OPTION FRAISAGE INFÉRIEUR SANS TROU

SOLEIRA OCULTA
CONCEALED SILL | SEUIL CACHÉ
OS 08

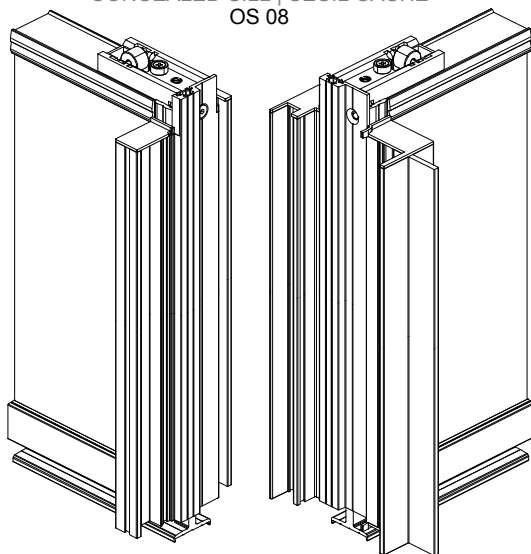

SOLEIRA OCULTA
CONCEALED SILL | SEUIL CACHÉ
OS 18

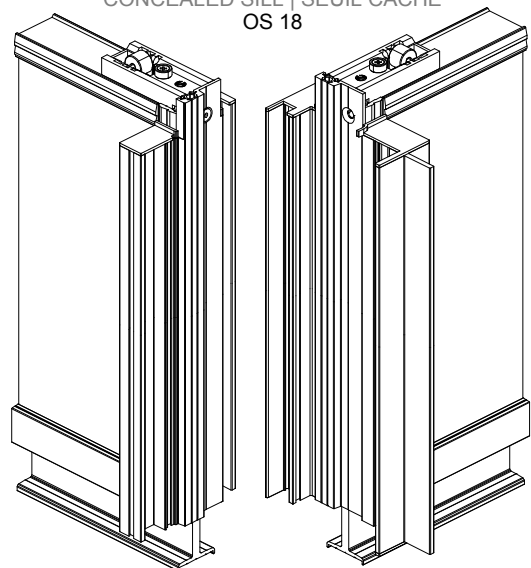

APLICAÇÃO DO CONJUNTO TOPOS SO 38/ SO 39
END CAP APPLICATION
APPLICATION DE EMBOUT

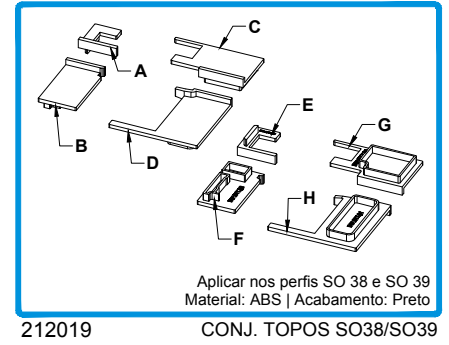
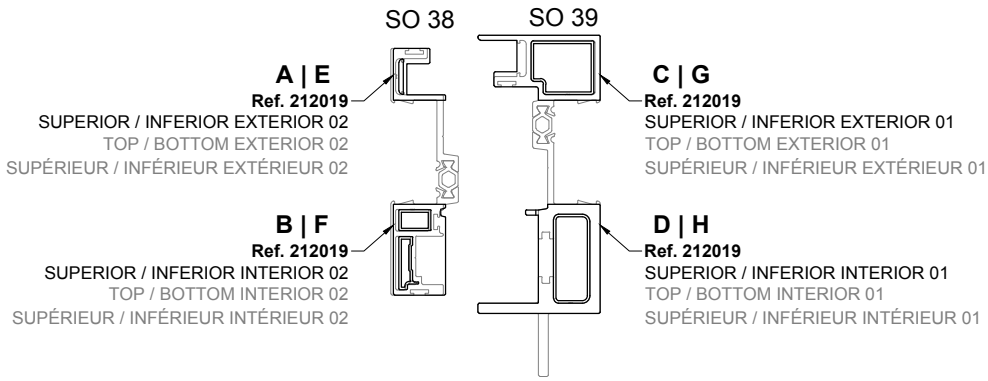

ZONA SUPERIOR TOP ERA MEIL ZONE SUPÉRIEURE	<p>CONJ. TOPOS SO 38/ SO 39 SUPERIORES UPPER END-CAP KIT KIT D'EMBOUTS SUPÉRIEURES</p>	<p>IMPORTANTE IMPORTANT IMPORTANT:</p> <p>Proteger os cortes com corretor nas zonas em que não fica tapado pelos topos</p> <p>Protect the cuts with a corrector in the areas where it is not covered by end-caps</p> <p>Protéger les coupures avec un correcteur dans les zones où il n'est pas couvert par les embouts</p>	<p>OPÇÕES DE MALHETE INFERIOR APARAFUSADO OU SEM FURO BOTTOM MILLING OPTIONS SCREWED OR WITHOUT HOLE OPTIONS DE FRAISAGE INFÉRIEUR VISSÉ OU SANS TROU</p>
SOLEIRA TRADICIONAL CLASSIC SILL SEUIL CLASSIQUE	<p>CONJ. TOPOS SO 38/ SO 39 INFERIORES BOTTOM END-CAP KIT KIT D'EMBOUTS INFÉRIEURES</p>		
SOLEIRA OCULTA - OS 08 CONCEALED SILL SEUIL CACHÉ	<p>CONJ. TOPOS SO 38/ SO 39 INFERIORES - NÃO USAR BOTTOM END-CAP KIT - DO NOT USE KIT D'EMBOUTS INFÉRIEURES - NE PAS UTILISER</p>	<p>OPÇÃO SOLEIRA OCULTA OS 08 E OS 18 SEM TOPOS OS 08 AND OS 18 CONCEALED SILL OPTION WITHOUT END CAP OPTION CACHÉ SEUIL OS 08 ET OS 18 SANS COUVERTURE</p>	
SOLEIRA OCULTA - OS 18 CONCEALED SILL SEUIL CACHÉ	<p>IMPORTANTE IMPORTANT IMPORTANT: Proteger os cortes com corretor Protect cuts with corrector Protéger les coupures avec un correcteur</p>		

APLICAÇÃO DO CONJUNTO TOPOS CENTRAIS - SOLEIRA OCULTA OS 08 e OS 18

CENTRAL PART APPLICATION - CONCEALED SILL

APPLICATION DE PIÈCE CENTRAL - SEUIL CACHÉ

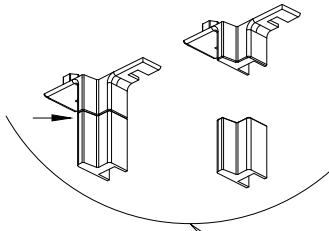

NOTA | NOTE | IMPORTANT:
 Proceder ao corte das peças para aplicar no perfil OS 08
 Proceed to cut the pieces to apply to the OS 08 profile
 Procéder à la découpe des pièces à appliquer sur le profil OS 08

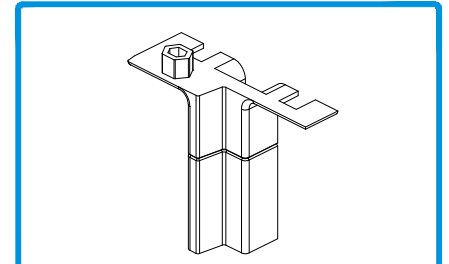

Para os perfis SO38/SO39, com os perfis OS 08 e OS 18
 Material: ABS | Acabamento: Preto

210227 TOPO INF. SOL. OCULTA SO38/SO39 PRT

NOTA | NOTE | NOTE:
 Colar os topo ao perfil OS 08
 Glue the central parts to the OS 08 profile
 Coller les pièces centrales au profil OS 08

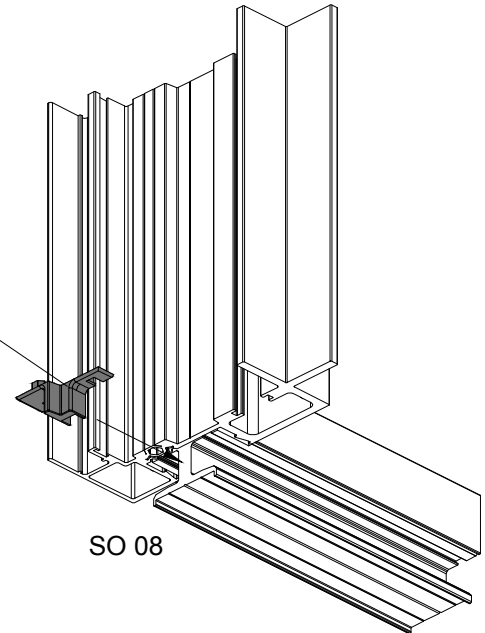
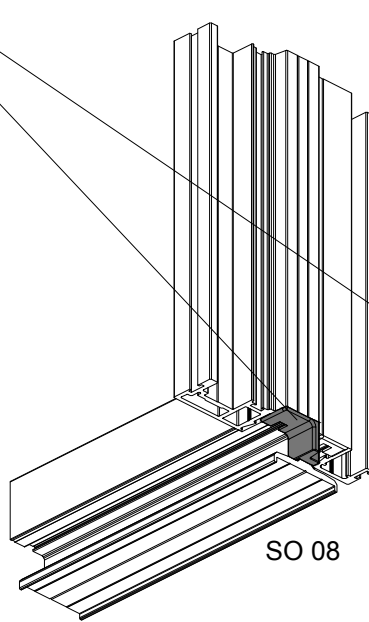

NOTA | NOTE | NOTE:
 Colar os topo ao perfil OS 18
 Glue the central parts to the OS 18 profile
 Coller les pièces centrales au profil OS 18

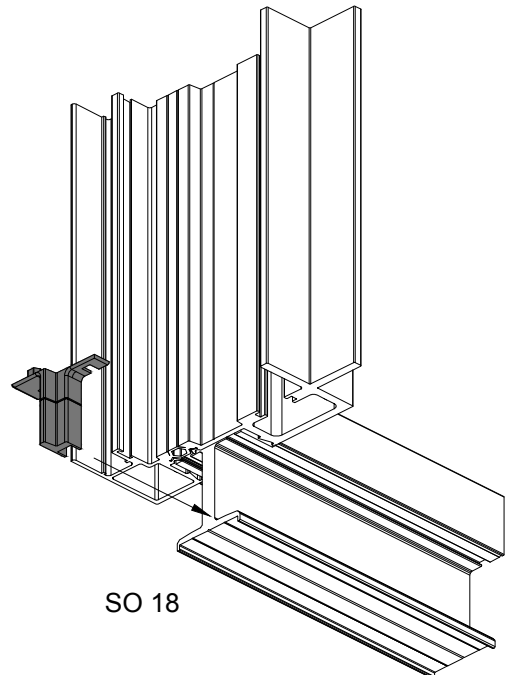
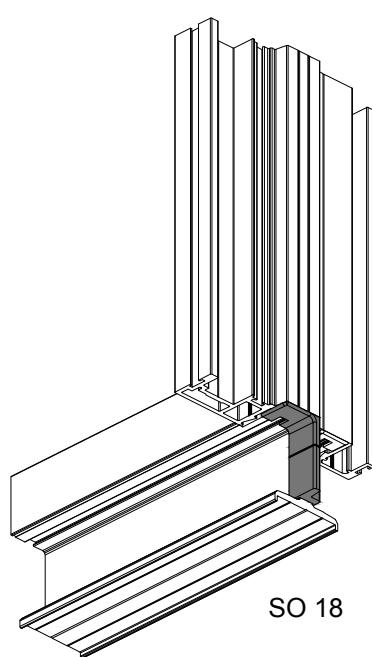

APLICAÇÃO DOS CONJUNTOS DE TOPOS SUP/INF SO 10 - SOLEIRA TRADICIONAL
APPLICATION OF THE SO 10 END-CAP KIT - CLASSIC SILL
APPLICATION DES KITS D'EMBOUITS SO 10 - SEUIL CLASSIC

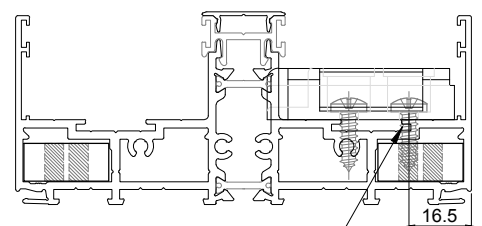
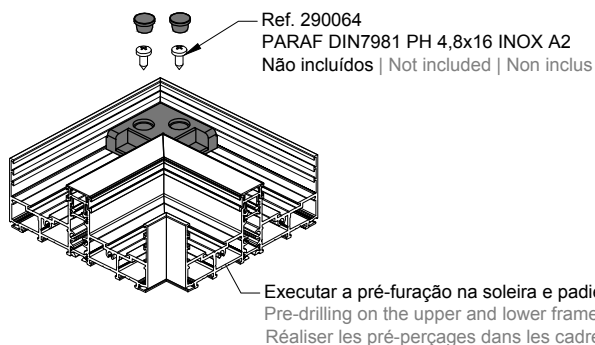
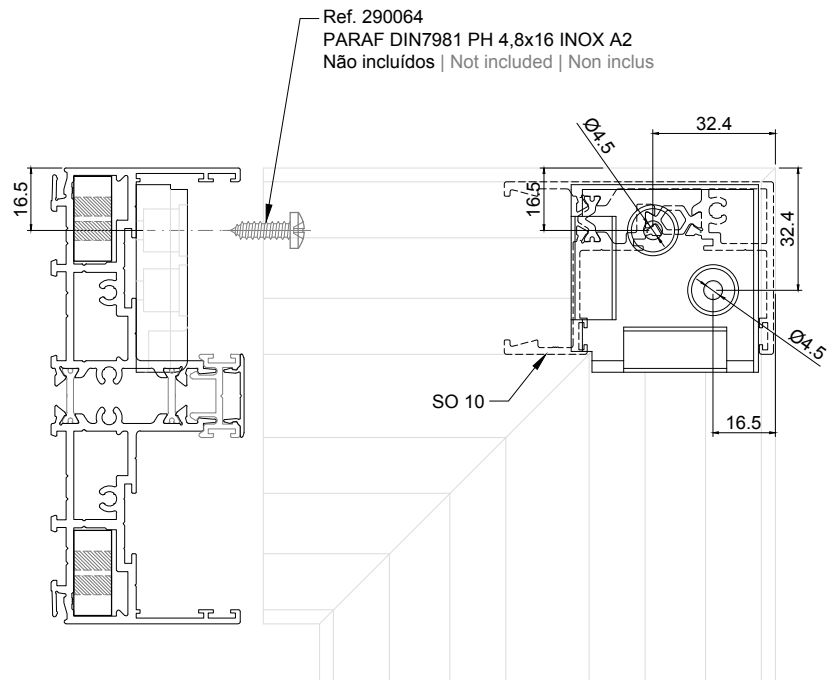
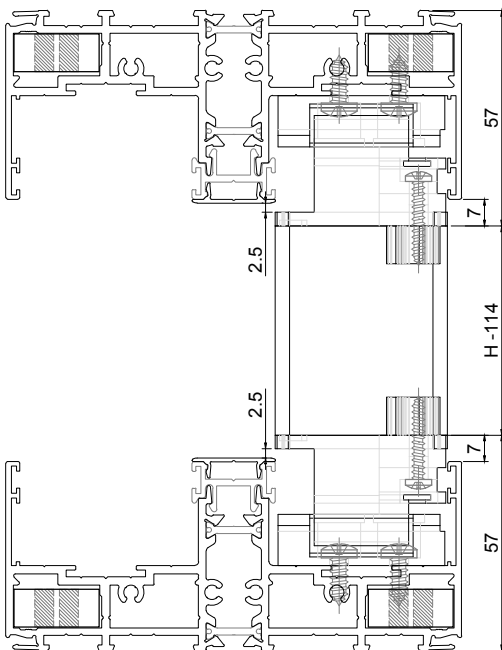
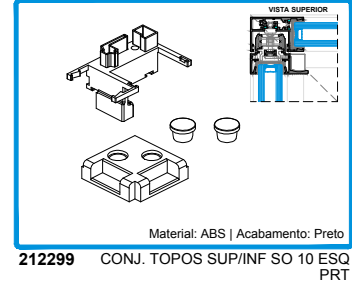
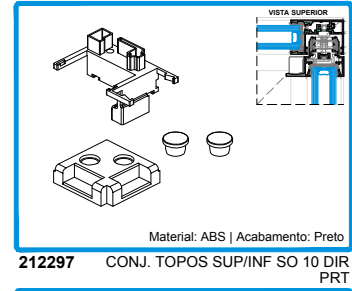
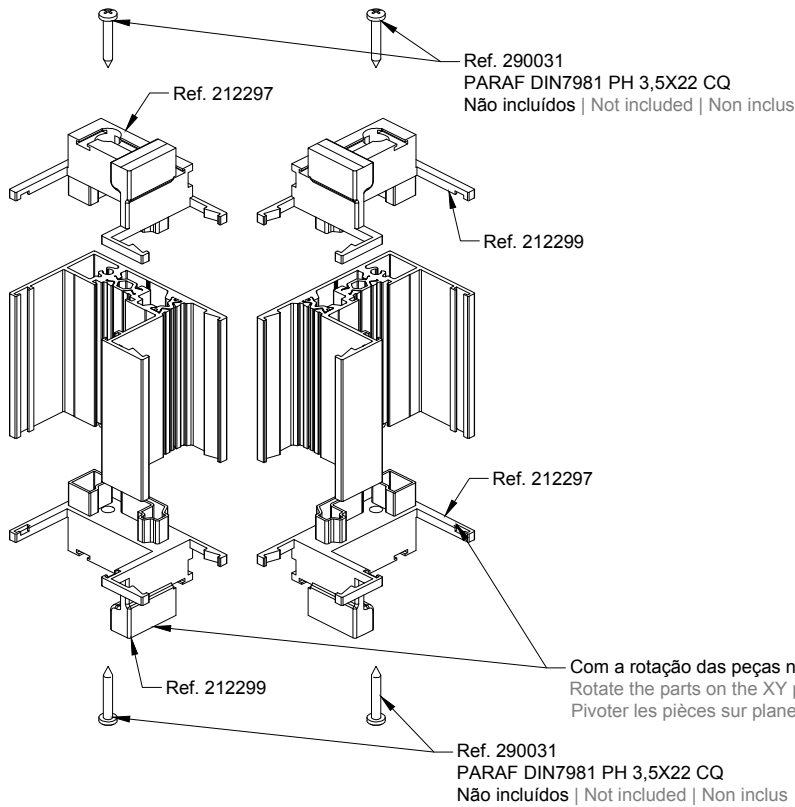

APLICAÇÃO DOS CONJUNTOS DE TOPOS SUP/INF SO 10 NO ARO FIXO - SOLEIRA OCULTA

APPLICATION OF THE SO 10 END-CAP KIT ON THE FIXED FRAME - CONCEALED SILL

APPLICATION DES KITS D'EMBOUTS SO 10 SUR LE CHÂSSIS FIXE - SEUIL CACHÉE

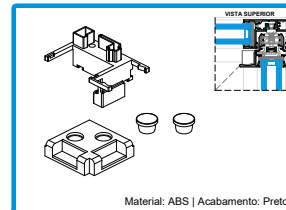
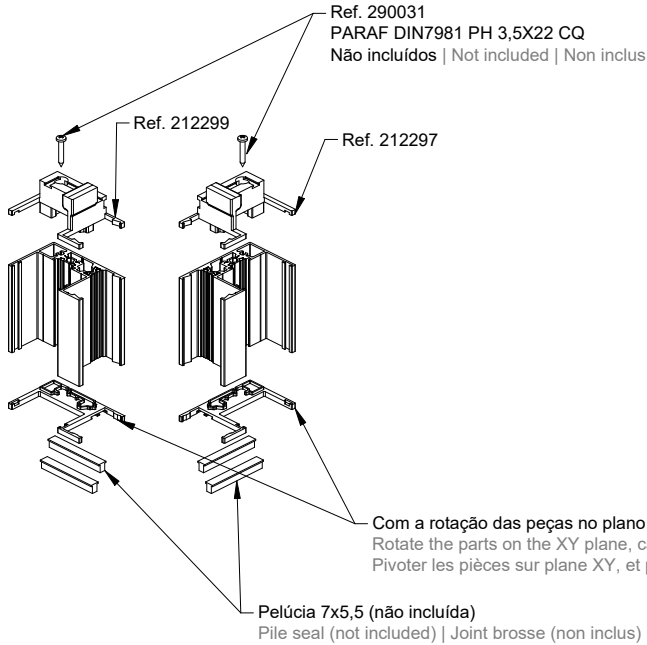

212297 CONJ. TOPOS SUP/INF SO 10 DIR PRT

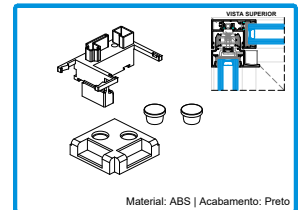

212299 CONJ. TOPOS SUP/INF SO 10 ESQ PRT

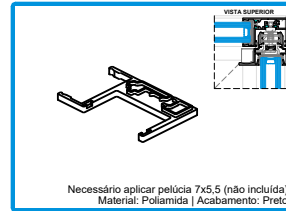

210221 TOPO INF SOL. OCULTA SO 10 DRT.

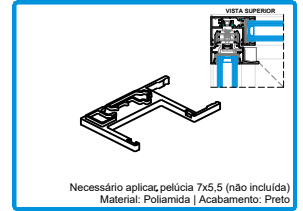

210223 TOPO INF SOL. OCULTA SO 10 ESQ.

Com a rotação das peças no plano XY, obtêm-se as peças esquerdas ou direitas.

Rotate the parts on the XY plane, can get left or right device.

Pivoter les pièces sur plane XY, et peut obtenir les gouche ou droit pièce.

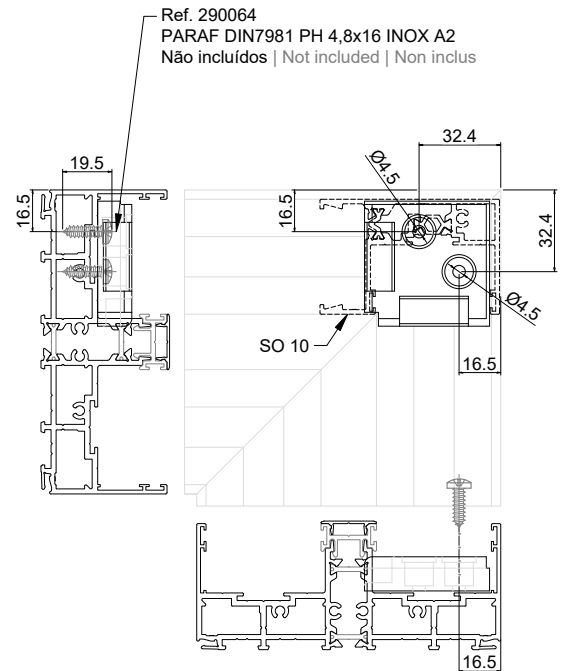
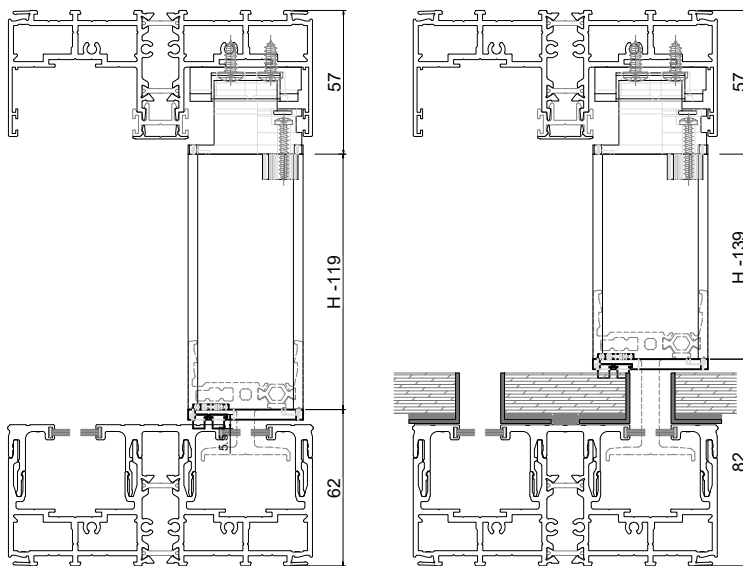

Executar a pré-furação apenas na padieira.

Pre-drilling only on the upper frame profile.

Réaliser les pré-perçages uniquement dans le cadre supérieur.

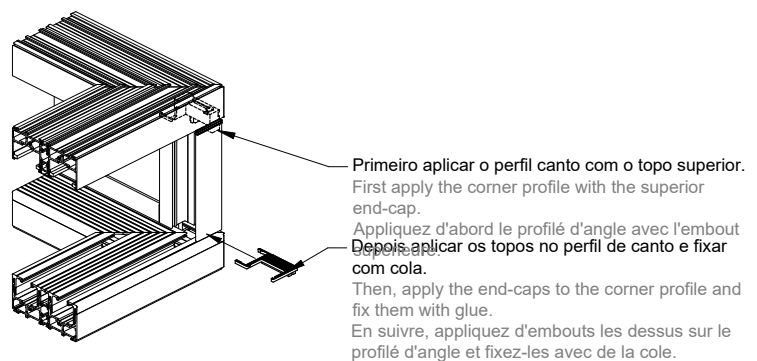
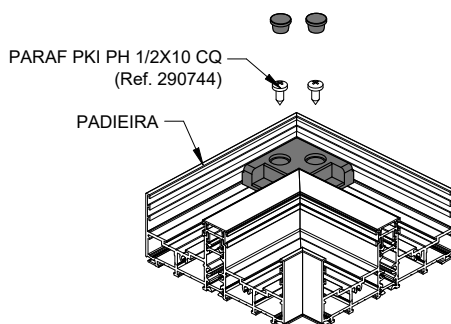

APLICAÇÃO DOS CONJUNTOS DE TOPOS SUP/INF SO 10 - 1 FOLHA CORRER + 1 FIXO - SOLEIRA TRADICIONAL
APPLICATION OF THE SO 10 END-CAP KIT - 1 SLIDING SASH + 1 FIXED FRAME - CLASSIC SILL
APPLICATION DES KITS D'EMBOUTS SO 10 - 1 VANTAIL COULISSANT + 1 FIXE - SEUIL CLASSIC

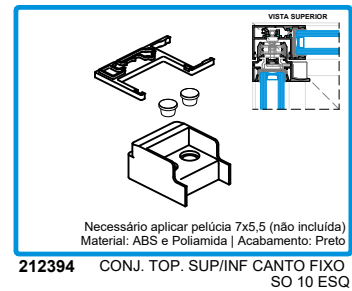
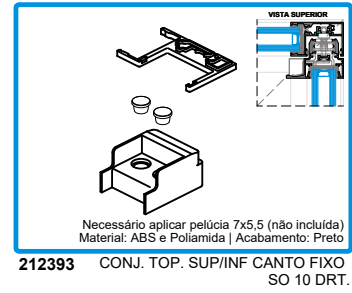
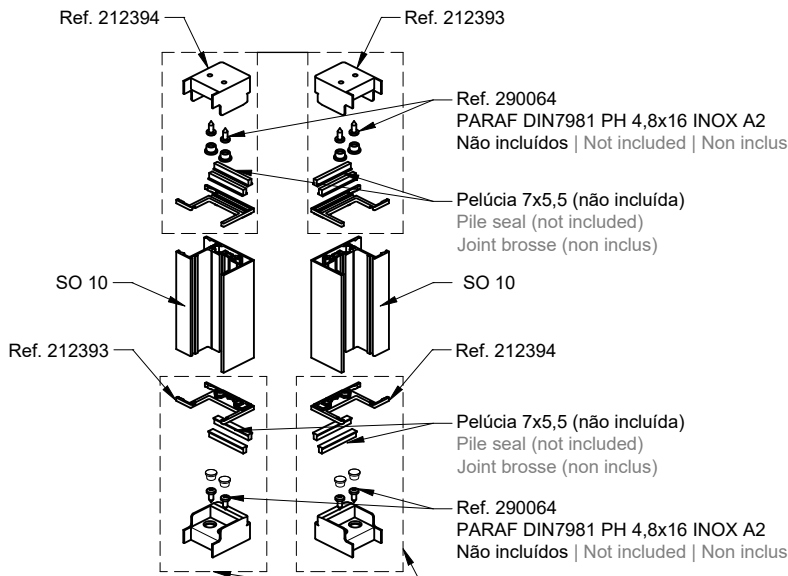

Com a rotação das peças no plano XY, obtêm-se as peças esquerdas ou direitas.
Rotate the parts on the XY plane, can get left or right device.
Pivoter les pièces sur plane XY, et peut obtenir les gouche ou droit pièce.

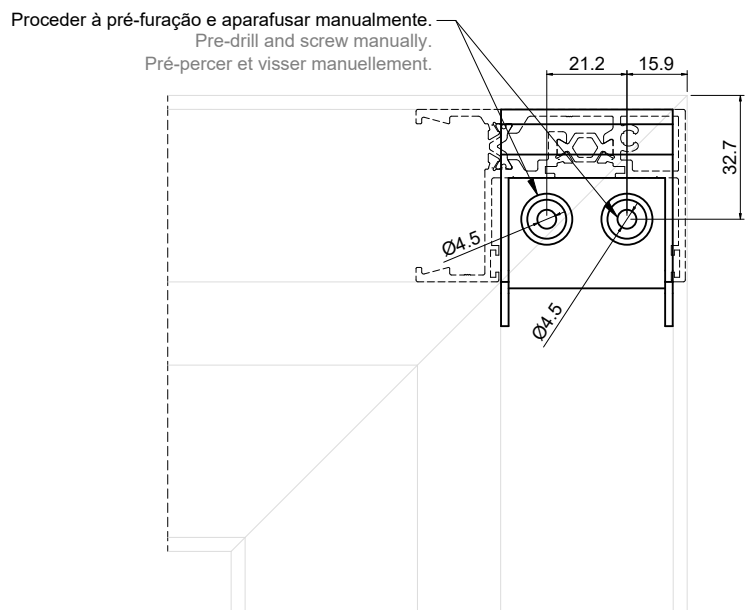
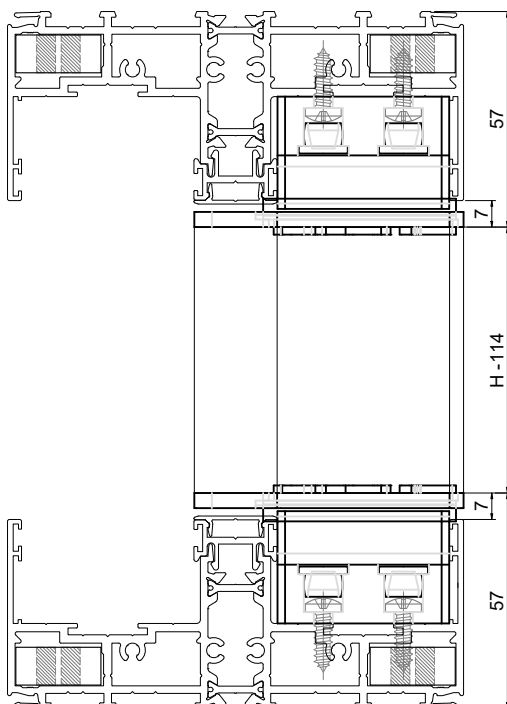
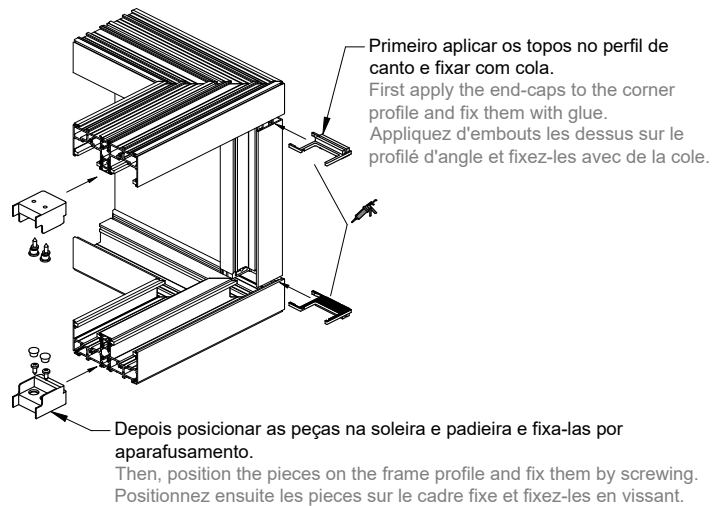
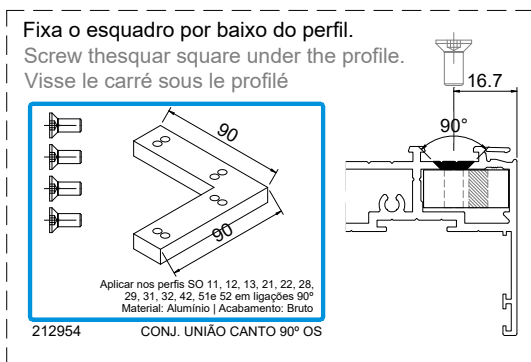

APLICAÇÃO DOS CONJUNTOS DE TOPOS SUP/INF SO 10 - 1 FOLHA CORRER + 1 FIXO - SOLEIRA OCULTA
APPLICATION OF THE SO 10 END-CAP KIT - 1 SLIDING SASH + 1 FIXED FRAME - CONCEALED SILL
APPLICATION DES KITS D'EMBOUTS SO 10 - 1 VANTAIL COULISSANT + 1 FIXE - SEUIL CACHÉE

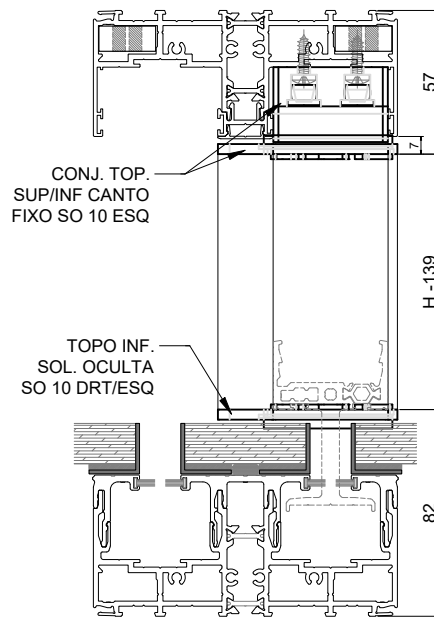
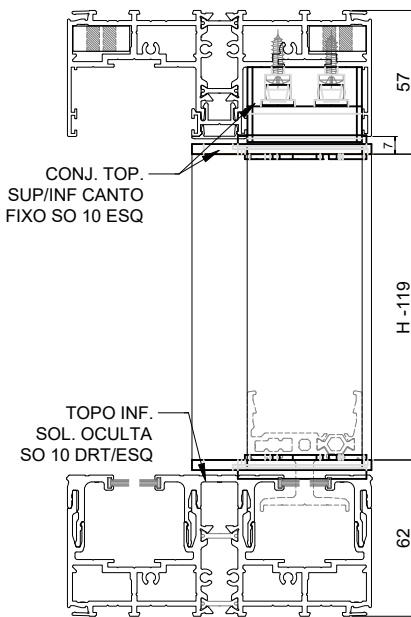
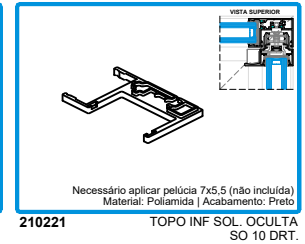
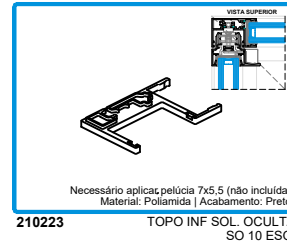
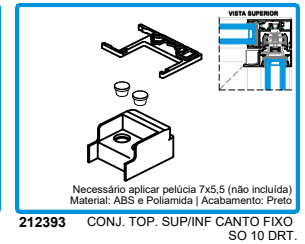
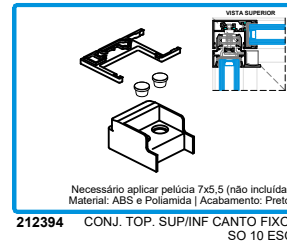
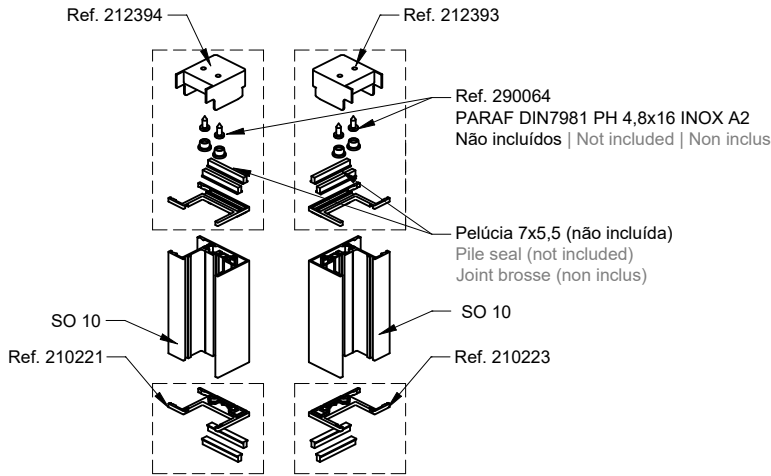

Proceder à pré-furação e aparafusar manualmente.
Pre-drill and screw manually.
Pré-percer et visser manuellement.

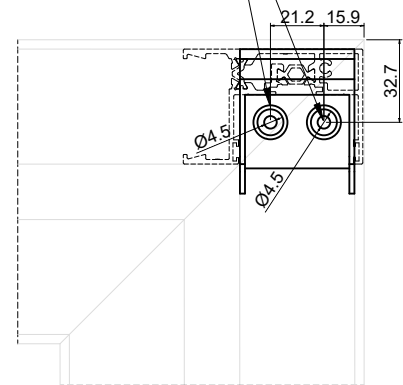

Fixa o esquadro por baixo do perfil.
Screw the square under the profile.
Visse le carré sous le profilé

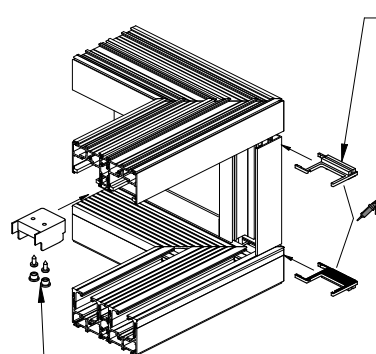
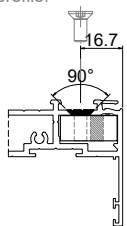
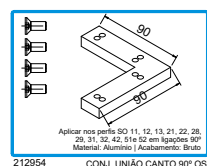

Primeiro aplicar os topos no perfil de canto e fixar com cola.
First apply the end-caps to the corner profile and fix them with glue.
Appliquez d'embouts les dessus sur le profilé d'angle et fixez-les avec de la colle.

Depois posicionar as peças na soleira e padieira e fixá-las por aparafusamento.
Then, position the pieces on the frame profile and fix them by screwing.
Positionnez ensuite les pieces sur le cadre fixe et fixez-les en vissant.

PORMENORES DE APLICAÇÃO DOS TOPOS SO 05, SO 06 E SO 07

SO 05, SO 06 AND SO 07 END-CAP APPLICATION DETAILS

DÉTAIL D'APPLICATION DES KIT D'EMBOUITS SO 05, SO 06 ET SO 07

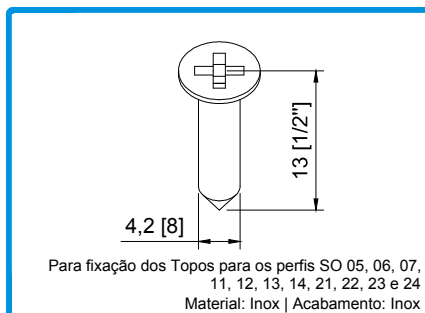

290061 PARAF. DIN7982 PH 4,2x13 INOX A2

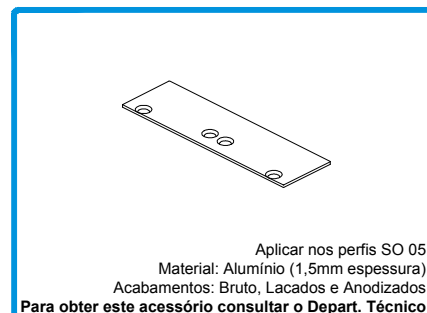

TOPO PARA SO 05

Topo para | End-cap for | Embout pour SO 05

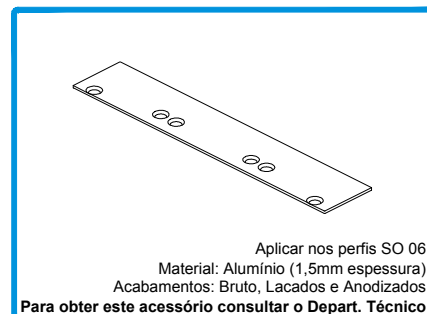
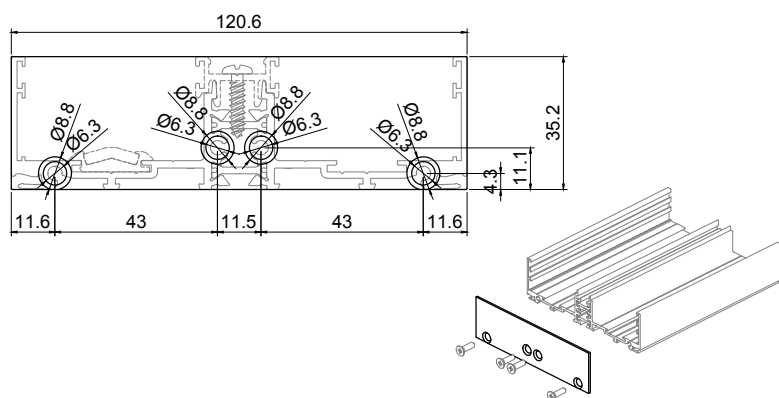

TOPO PARA SO 06

Topo para | End-cap for | Embout pour SO 06

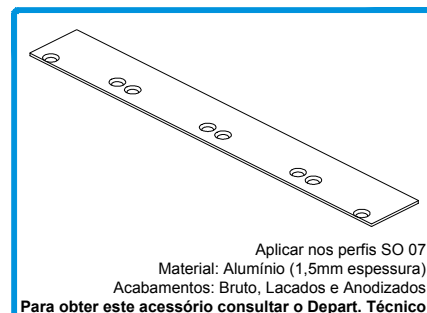
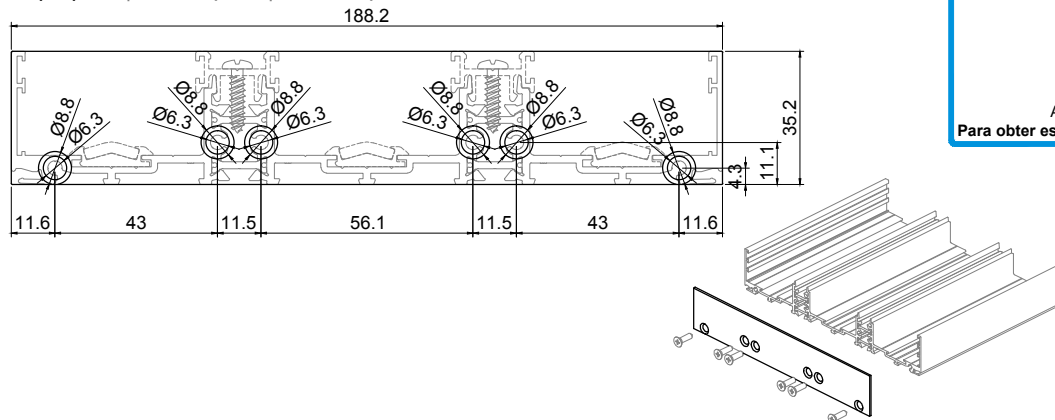

TOPO PARA SO 07

Topo para | End-cap for | Embout pour SO 07

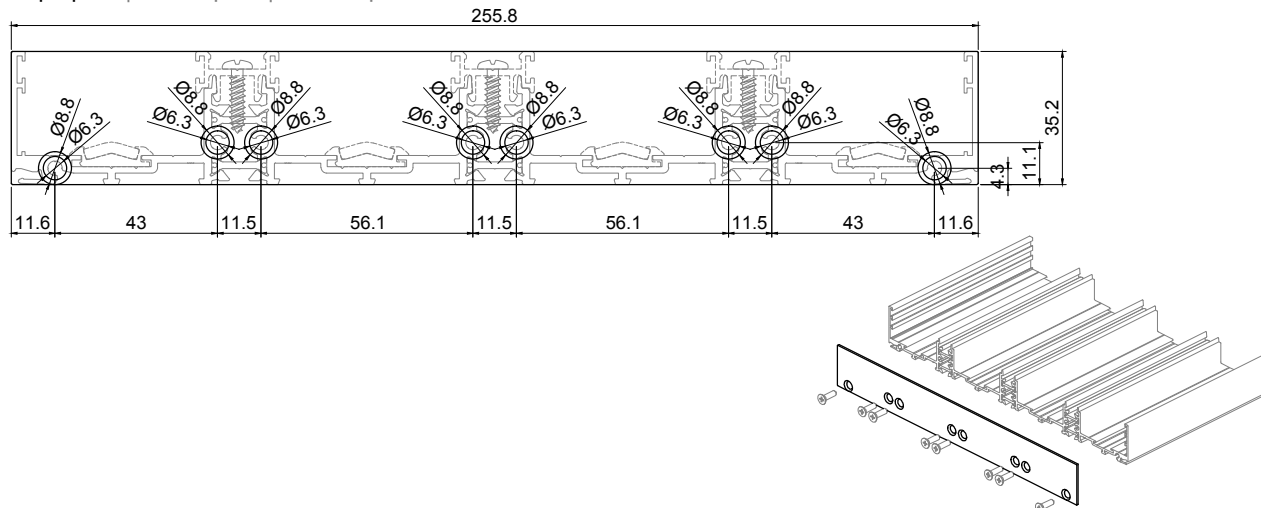

APLICAÇÃO DO FECHO LATERAL OS Nº4
OS NO. 4 LATERAL LOCK APPLICATION
APPLICATION DU FERMETURE LATÉRAL OS Nº4

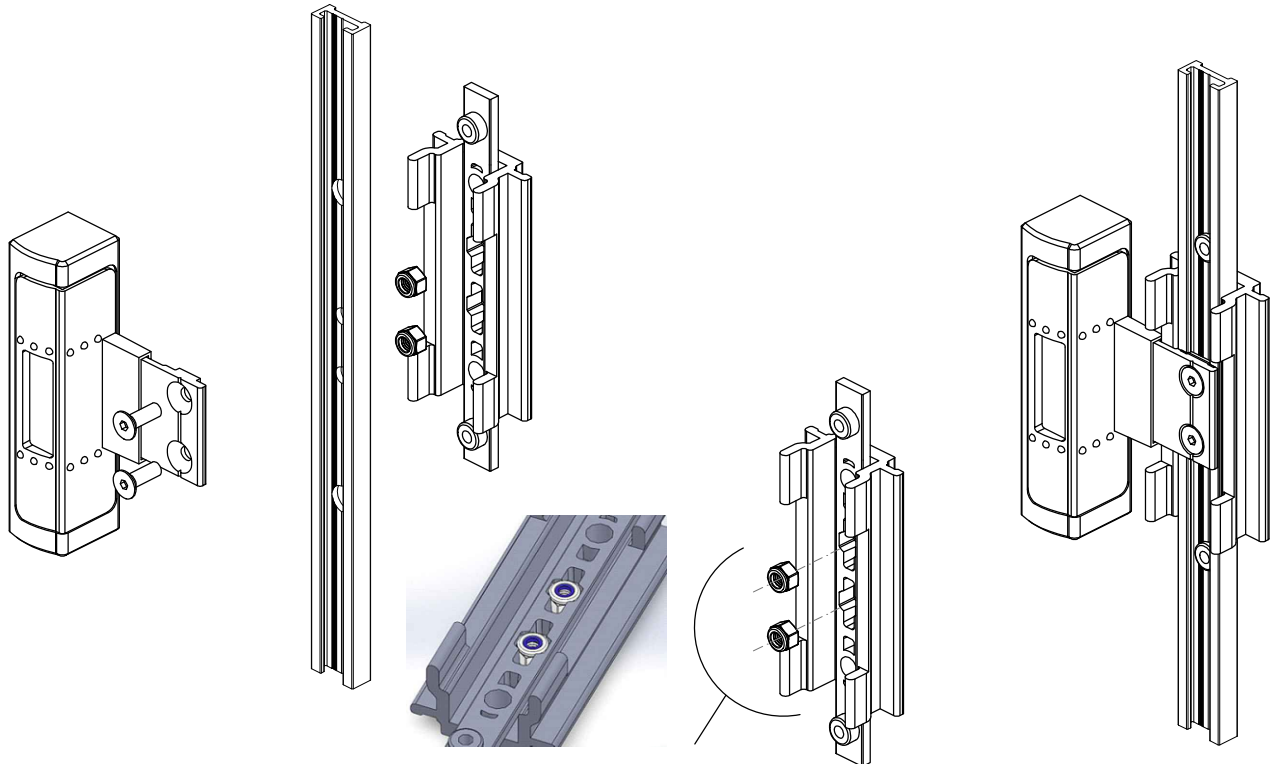
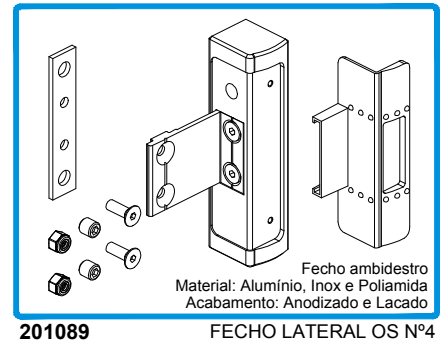
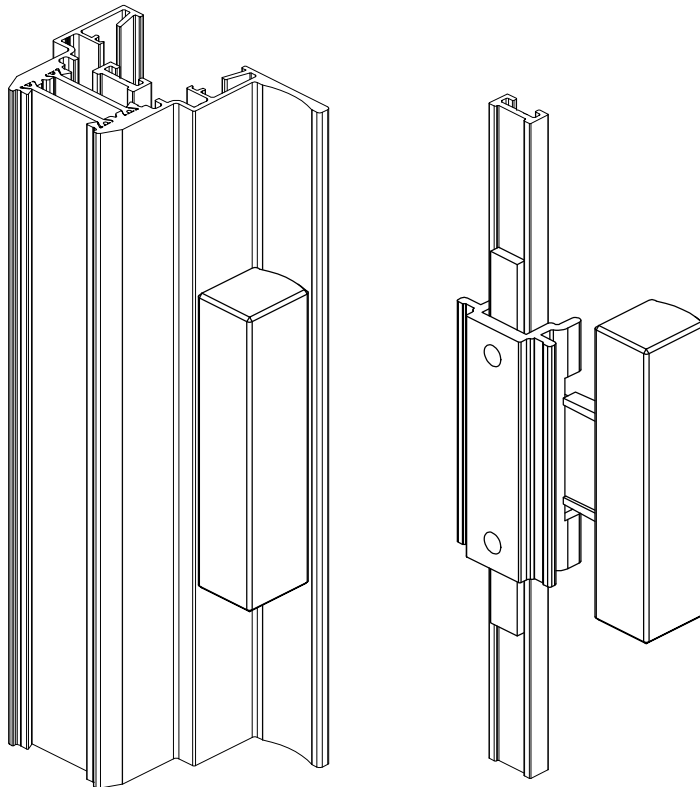

IMPORTANTE | IMPORTANT | IMPORTANT:

Aplicar as porcas freiadas DIN 985 inox-A2-M4 na peça de ajuste como o colar de nylon voltado para cima.
Apply the DIN 985 inox-A2 lock nuts to the adjustment piece with the nylon collar facing up.
Appliquer le contre-écrous DIN 985 en acier inoxydable A2 sur la pièce de réglage avec le collier en nylon vers le haut.

APLICAÇÃO DO FECHO LATERAL N.4 E GACHES
LOCK N.4 AND DEVICES APPLICATION
APPLICATION DE SERRURE N.4 ET DES DISPOSITIFS DE FERMETURE

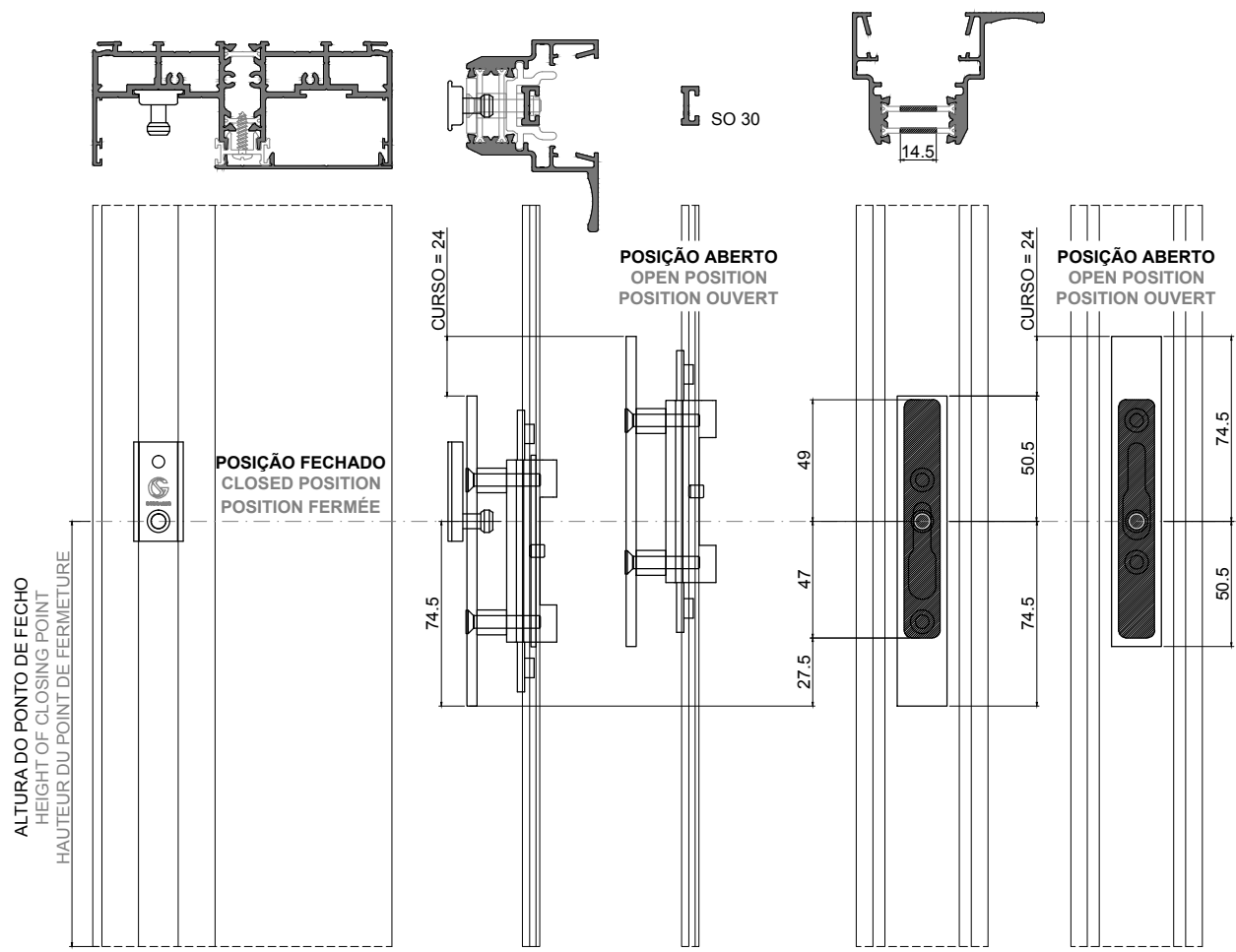
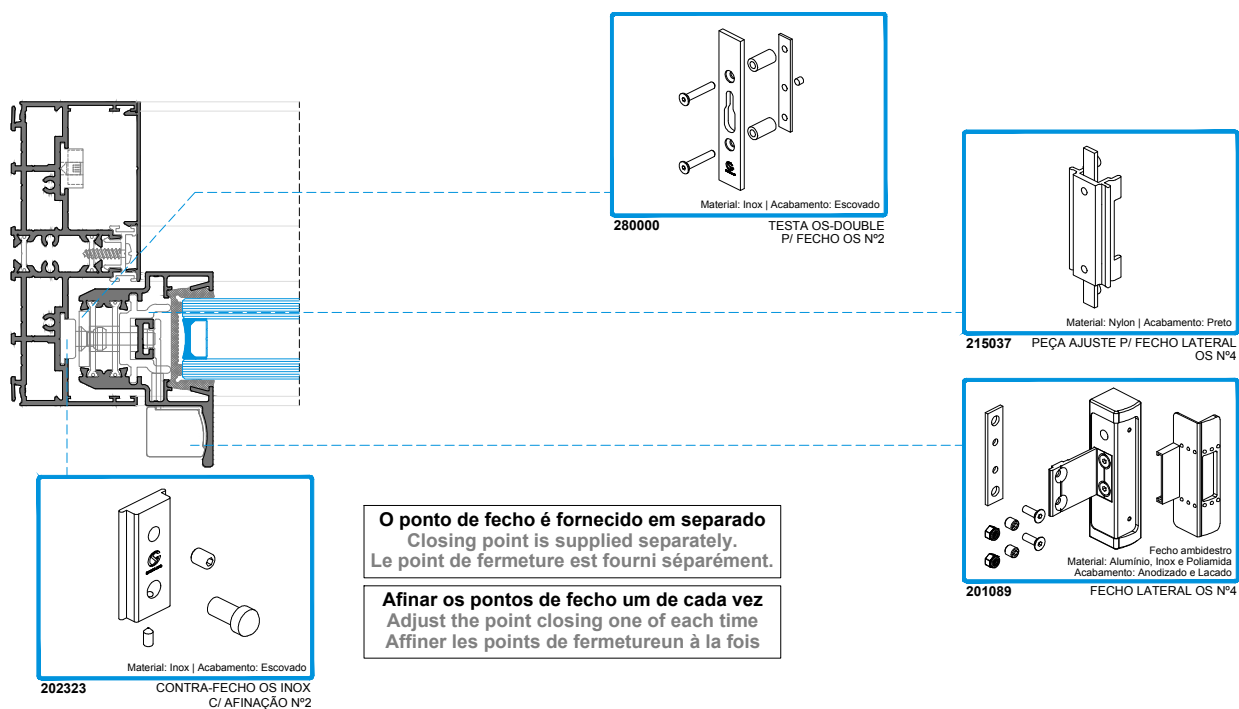

APLICAÇÃO DAS PEÇAS DE AJUSTE
ADJUSTMENT PIECES APPLICATION
APPLICATION DES PIÈCES DE REGLAGE

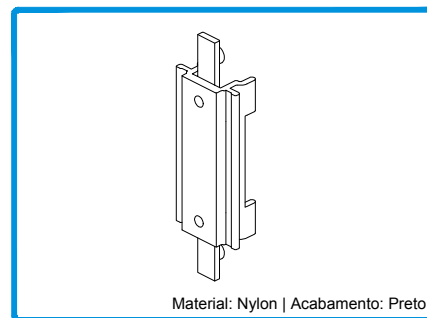

Material: Nylon | Acabamento: Preto

215037 PEÇA AJUSTE P/ FECHO LATERAL OS Nº4

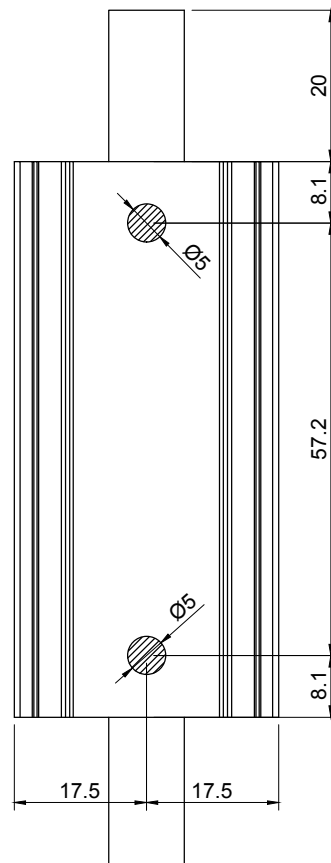
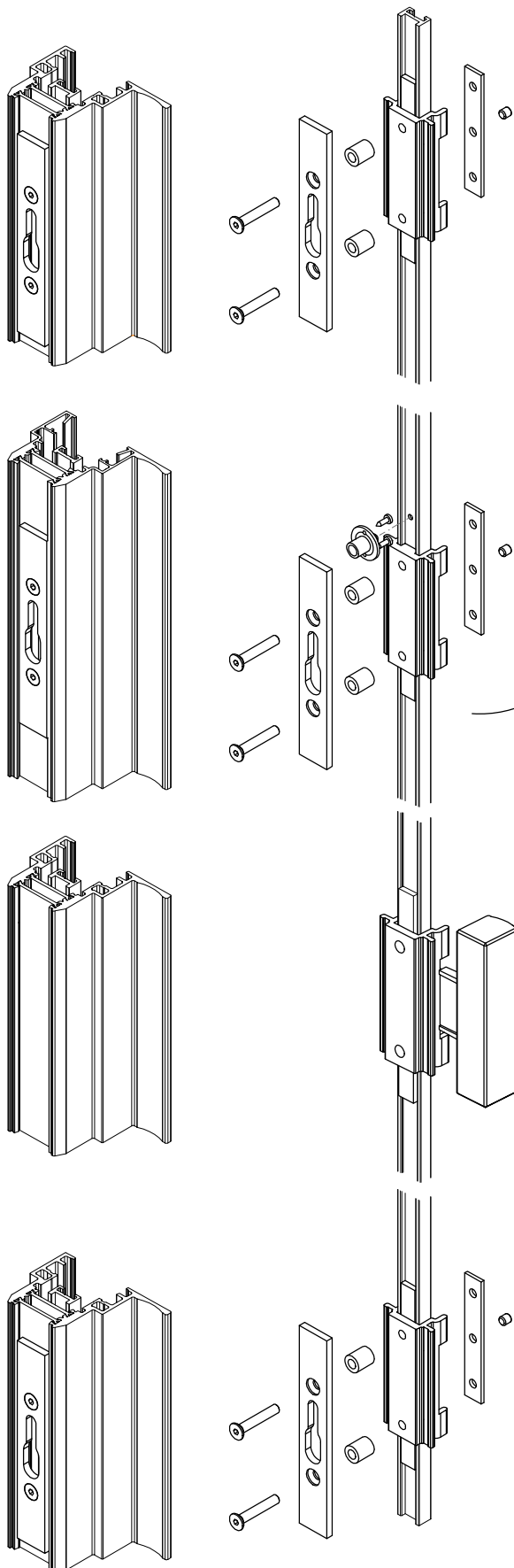

IMPORTANTE | IMPORTANT | IMPORTANT:

Necessário corte na zona superior da peça devido à proximidade à mola.
Necessary cut in the upper part of the piece due to the proximity to the spring.
Coupe nécessaire dans la partie supérieure de la pièce, en raison de la proximité du ressort.

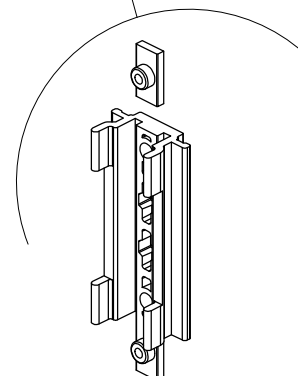

APLICAÇÃO DA MOLDA DE RETENÇÃO PARA FECHO OS Nº4
APPLICATION OF RETAINER SPRING FOR LOCK OS N.4
APPLICATION DE RESORT POUR RÉTENTION DE SERRURE OS N.4

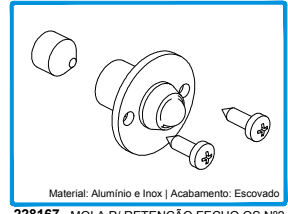

Posição "ABERTO"
"OPEN" position
Position "OUVERT"

24

90

Posição "FECHADO"
"CLOSED" position
Position "FERMÉ"

1. Puxar o Fecho Lateral para cima (**posição "aberto"**)
Push the Lateral Lock to the upper position ("open" position)
Tirer la Serrure vers le haut (**position "ouvert"**)

2. Fazer furo Ø3mm coincidente entre a vareta SO 30 e as poliamidas.
Make Ø3mm hole between SO 30 profile and polyamides.
Faire trou Ø3mm coïncidents entre le tige SO 30 et les polyamides.

Ø3.5

3. Retirar a vareta SO 30 e furar as 2 poliamidas com furo Ø10mm.
Remove the SO 30 profile and drill both polyamides with Ø10mm holes.
Retirer le tige SO 30 et faire les 2 polyamides avec des trous Ø10mm.

Ø10

13

passar as duas poliamidas
drill both polyamides
perforer les deux polyamides

Ø10

13

14.5

96

4. Aplicar a Mola de retenção e o parafuso
Apply the Retainer spring and the screw
Appliquer le Resort pour rétention et le vis

Posição "FECHADO"
"CLOSED" position
Position "FERMÉ"

24

5. Colocar novamente a vareta SO 30
Insert again the SO 30 profile
Remettre de nouveau le tige SO 30

6. Puxar o fecho para baixo (**Posição "fechado"**)
Push the lock down ("closed" position)
Pousser la serrure vers le bas (**position "fermé"**)

7. Utilizar um fixador de rosca do tipo LOCTITE e afinar a mola
Use fixing screw LOCTITE type and adjust the retainer spring
Utiliser freinage des filetages type LOCTITE et régler le ressort

FECHO DE EMBUTIR MONODIRECCIONAL
MONODIRECTIONAL RECESSED LOCK
SERRURE À ENCASTRER MONODIRECTIONNEL

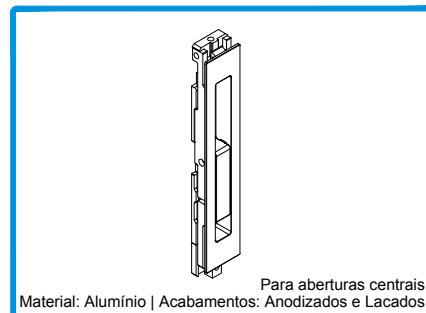

201097 FECHO DE EMBUTIR OS MONODIR.

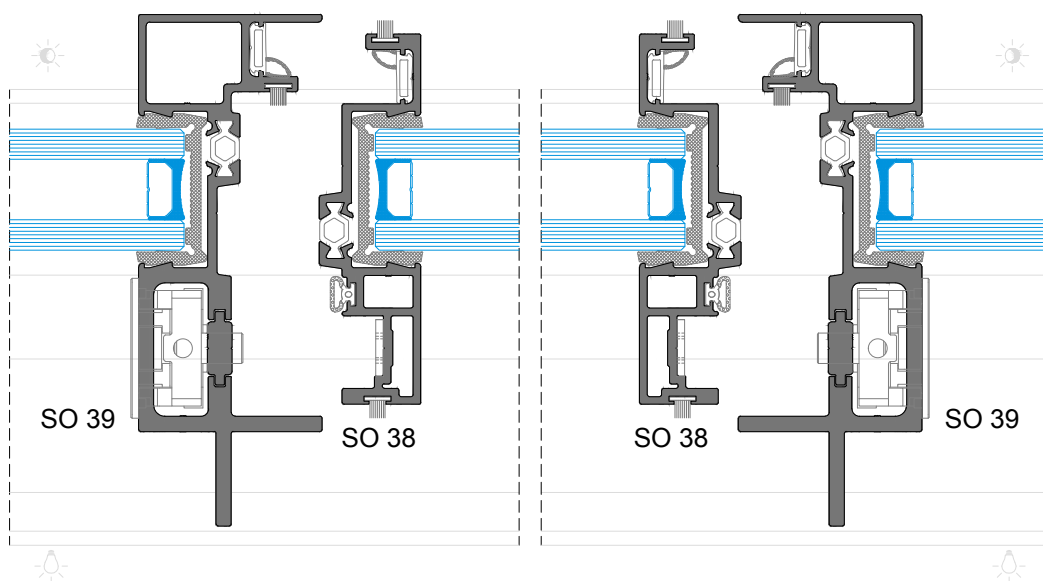
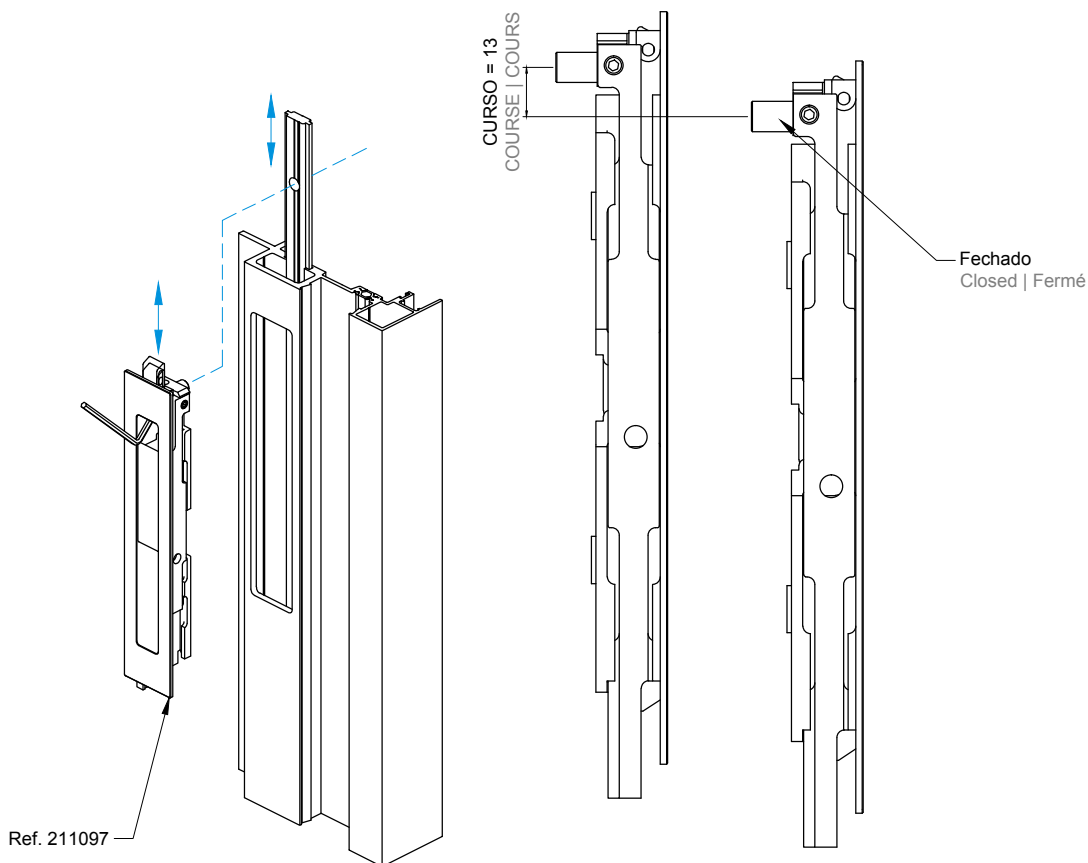

APLICAÇÃO DO FECHO DE EMBUTIR MONODIRECIONAL
MONO DIRECTIONAL RECESSED LOCK DEVICES APPLICATION
APPLICATION DE SERRURE À ENCASTRER MONODIRECTIONNEL

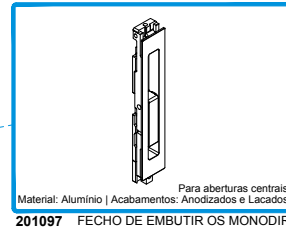
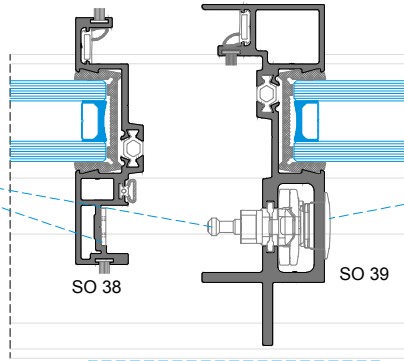
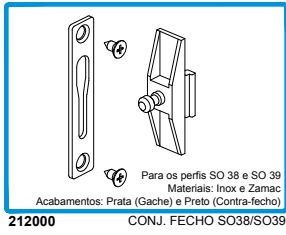

Afinar os pontos de fecho um de cada vez
Adjust the point closing one of each time
Affiner les points de fermeture un à la fois

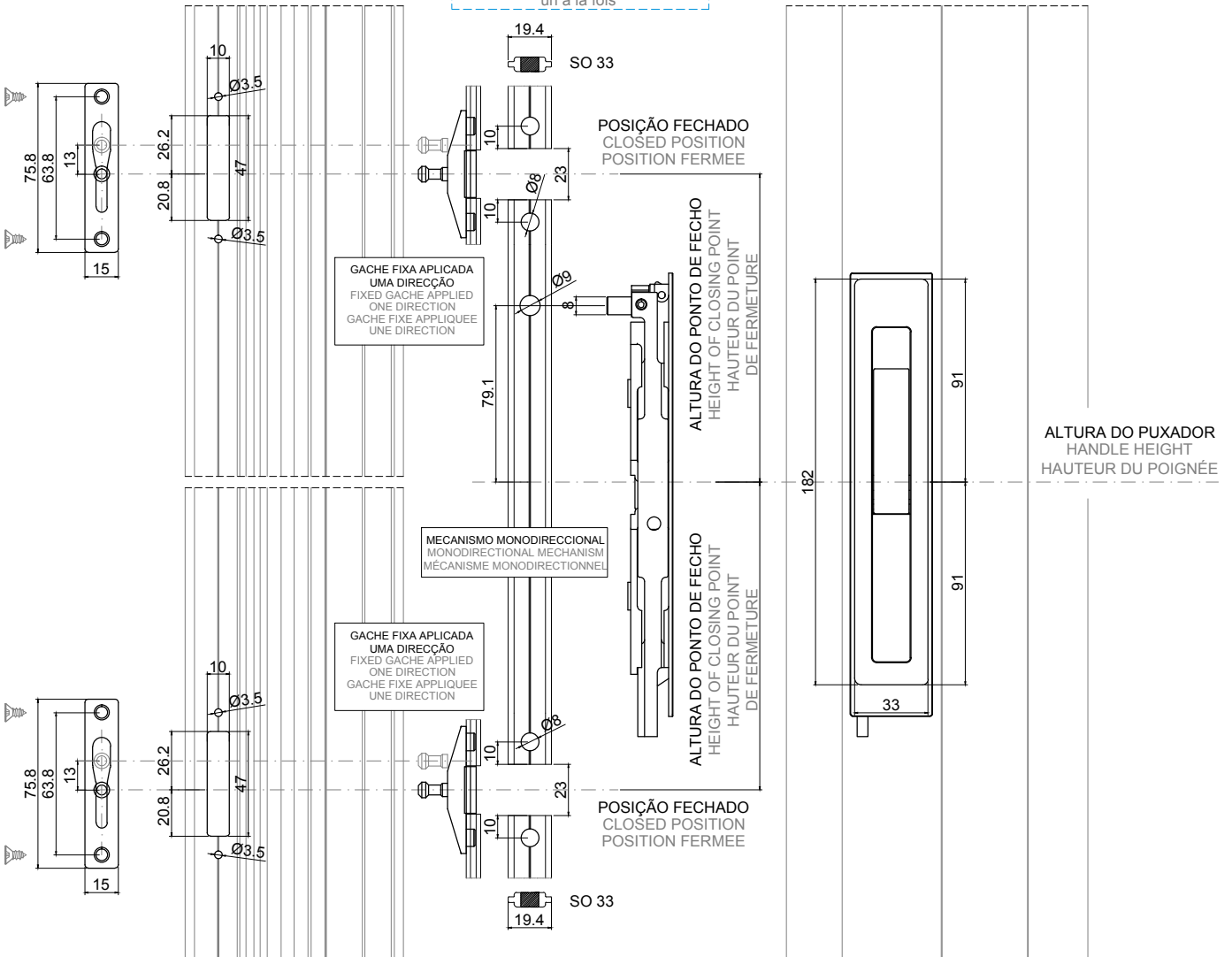
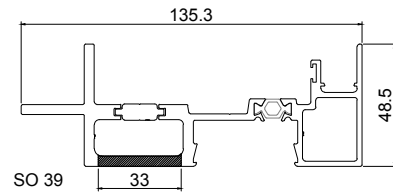
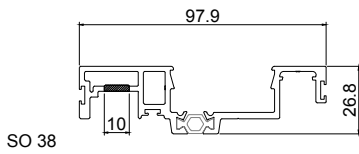

PORMENORES DE MONTAGEM DO FECHO CENTRAL OS Nº5
CENTRAL LOCK OS Nº5 ASSEMBLY DETAIL
DÉTAIL D'ASSEMBLAGE DE SERRURE CENTRAL OS Nº5

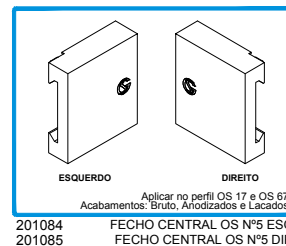

Maquinações no perfil OS 17
Machining on OS 17 profile
Usinage sur le profilé OS 17

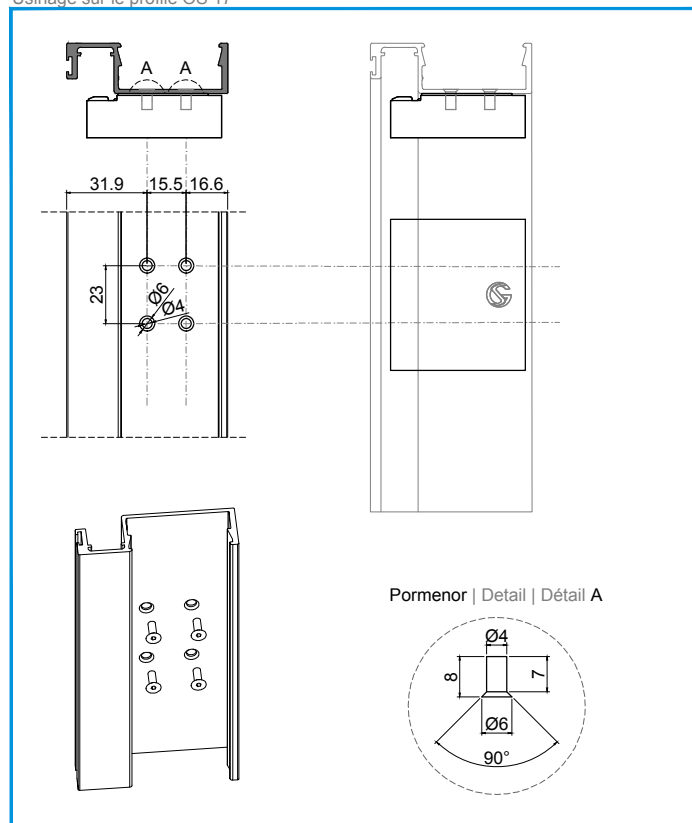

Maquinações no perfil OS 67
Machining on OS 67 profile
Usinage sur le profilé OS 67

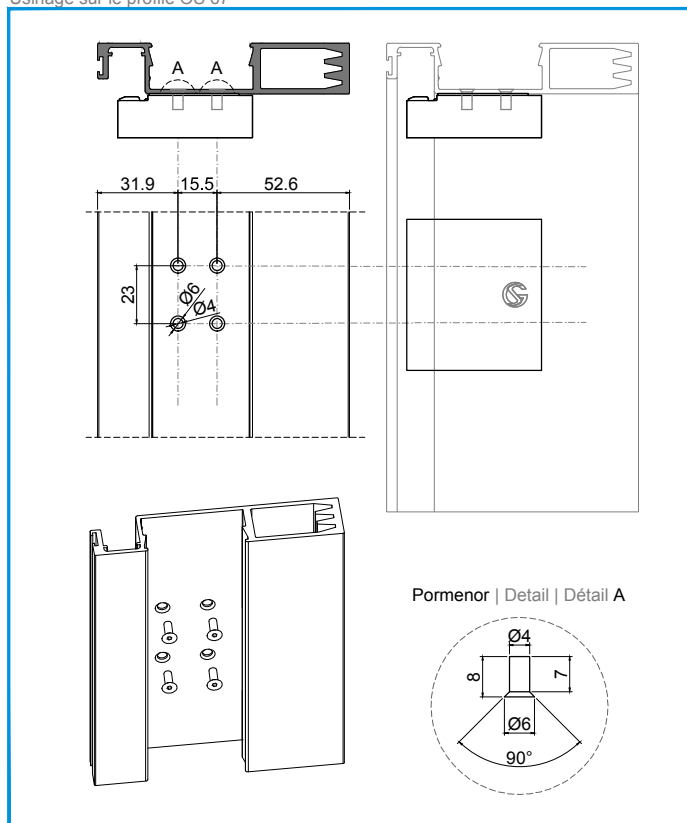

Pormenor de montagem no perfil OS 17
Assembly detail on OS 17 profile
Détail d'assemblage sur le profilé OS 17

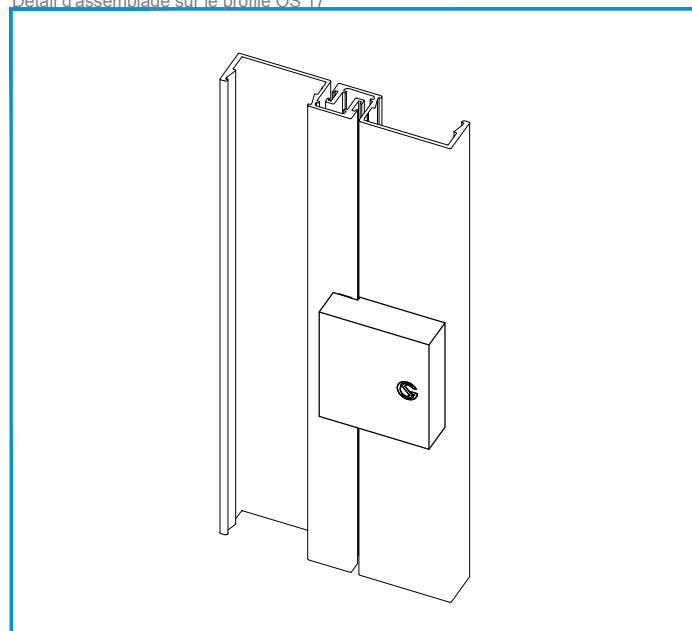

Pormenor de montagem no perfil OS 67
Assembly detail on OS 67 profile
Détail d'assemblage sur le profilé OS 67

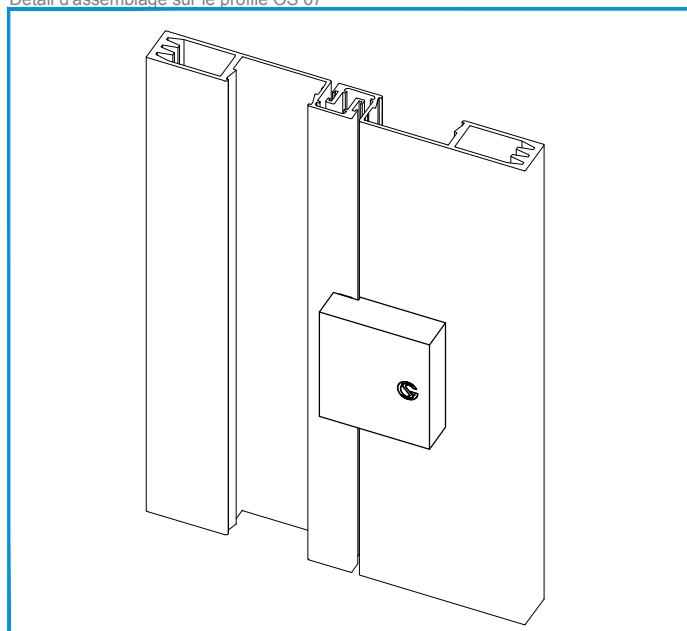

APLICAÇÃO DOS ACESSÓRIOS DE FECHADURA
LOCK ACCESSORIES APPLICATION
APPLICATION DES ACCESSOIRES DE SERRURE

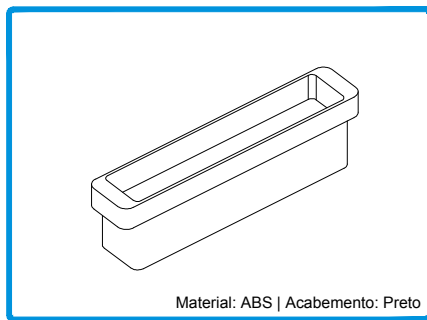

Material: ABS | Acabamento: Preto

203306

COPO P/ TESTA FECHADURA OS-D Nº2

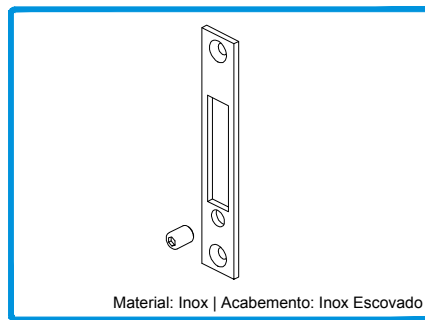

Material: Inox | Acabamento: Inox Escovado

280037

TESTA FECHADURA OS-D Nº2

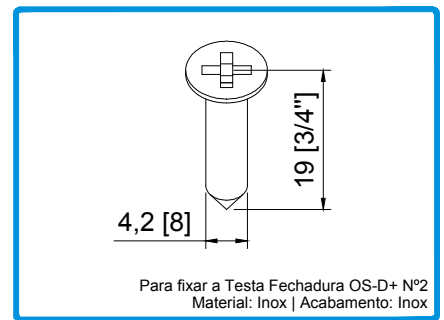

Para fixar a Testa Fechadura OS-D+ Nº2
Material: Inox | Acabamento: Inox

290105

PARAF. INOX A2 DIN7982 8X3/4 RB

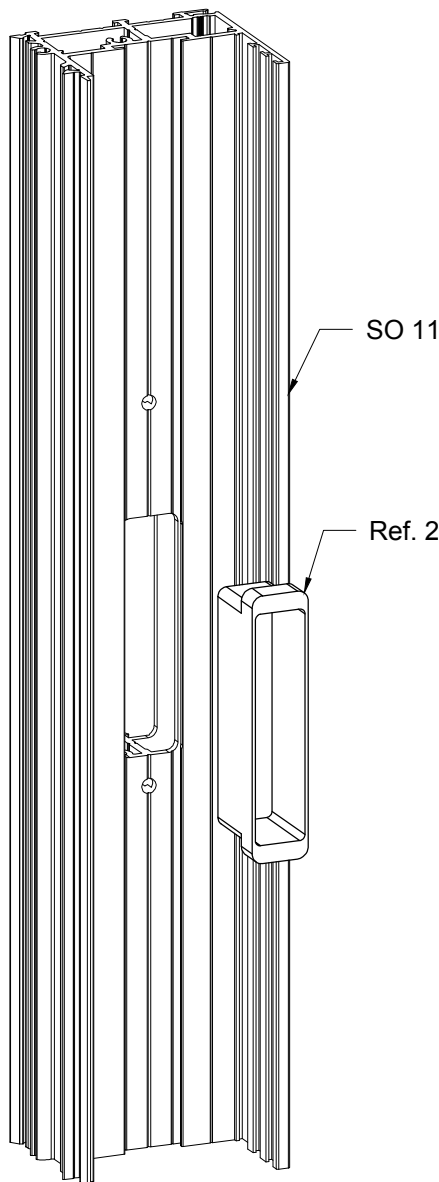

SO 11

Ref. 203306

IMPORTANTE | IMPORTANT | IMPORTANT:

O perfil SO 40 tem de ser colocado de gaveta, antes do fecho das esquadrias.

The SO 40 profile must be placed in a drawer, before closing the frames.

Le profilé SO 40 doit être placé dans un tiroir, avant de fermer les cadres.

SO 40

IMPORTANTE | IMPORTANT | IMPORTANT:

Furo com broca 3,25/3,5, escarear e fixar com 4,2x16
Drill hole with 3,35/3,5. Countersink and Fix with 4,2x16
Trou 3,25/3,5. Fraiser et fixé avec unde vis 4,2x16

Ref. 280037

Ref. 290105

IMPORTANTE | IMPORTANT | IMPORTANT:

Colar o perno depois de afinado
Glue the nut after adjustment.
Coller le vis après réglage

Ref. 290105

Importante | Important | Important:

Entalhar o perfil na zona inferior para a passagem da guia.

Mill the profile in the lower area for the passage of the guide.

Fraiser le profilé dans la zone inférieure pour le passage du guide.

APLICAÇÃO DO AMORTECEDOR N°3
SHOCK ABSORBER NO.3 APPLICATION
APPLICATION DE L'AMORTISSEUR N°3

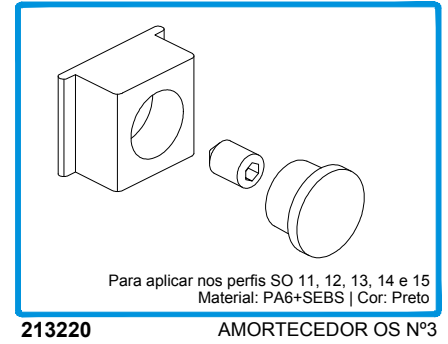
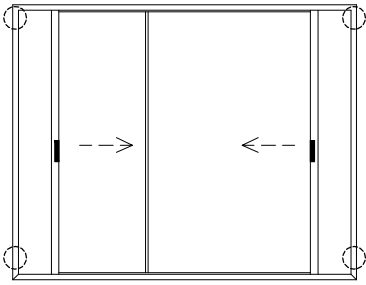

Os Amortecedores deverão ser posicionados nas zonas superior e inferior do perfil ombreira, de forma a fazerem de batente ao perfil lateral (em baixo, colocar acima da peça anti-levantamento da guia inox OS).

The Shock Absorbers must be positioned in the upper and lower zones of the jamb profile, in order to stop the lateral profile (in the bottom, place above the anti-lifting part of the OS stainless steel guide).

Les Amortisseurs doivent être positionnés dans les zones supérieure et inférieure du profilé de jambage, de manière à arrêter le profilé latéral (en bas, placer au-dessus de la partie anti-soulèvement du guide en acier inoxydable OS).

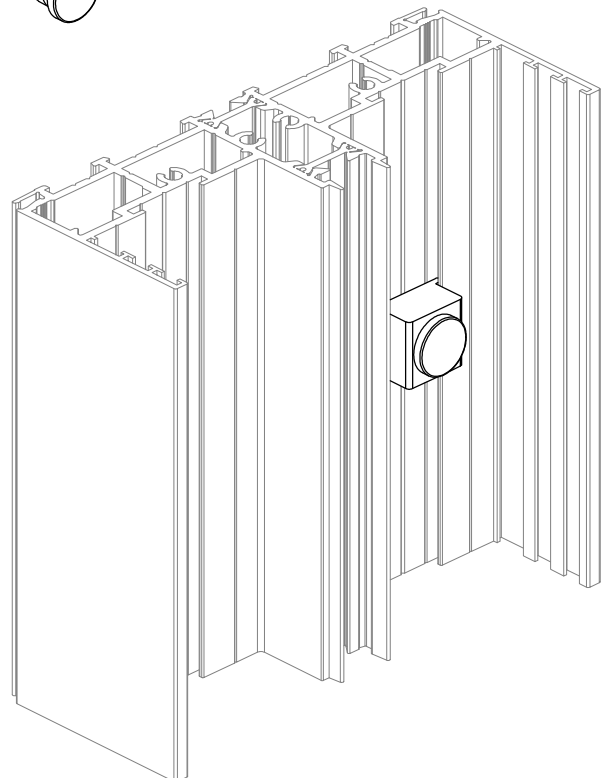
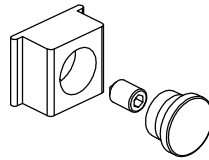
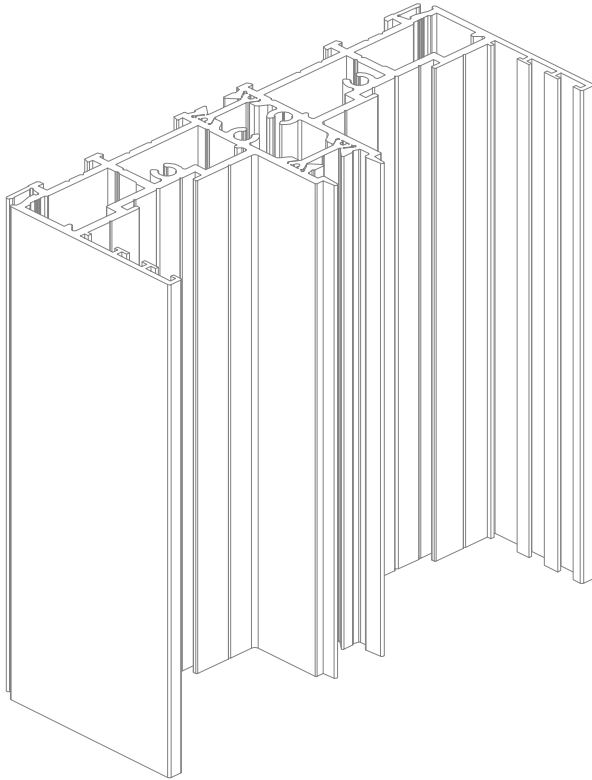

FIXAÇÃO DOS CAIXILHOS EM OBRA
FRAMES FIXING
FIXATION DES CHÂSSIS

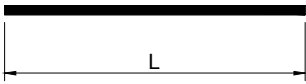
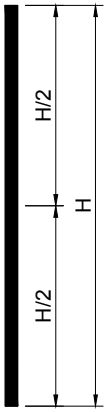
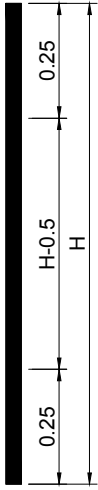
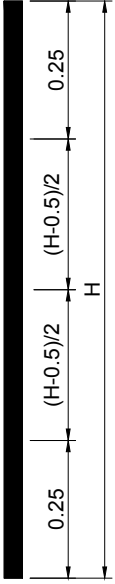
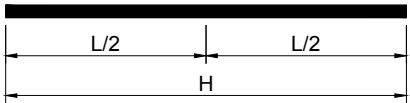
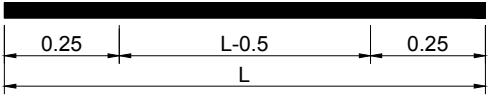
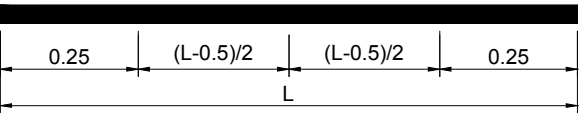
<p style="text-align: center;">$L \leq 0,90 \text{ m}$</p>  <p>Nenhuma fixação No fixations Pas des fixations</p>	<p style="text-align: center;">$H \leq 0,65\text{m}$</p>  <p>1 Fixação 1 Fixation 1 Fixation</p>	<p style="text-align: center;">$0,65\text{m} < H \leq 1,45\text{m}$</p>  <p>2 Fixações 2 Fixations 2 Fixations</p>	<p style="text-align: center;">$1,45\text{m} < H \leq 2,45\text{m}$</p>  <p>3 Fixações 3 Fixations 3 Fixations</p>
<p style="text-align: center;">$0,90 < L \leq 1,60 \text{ m}$</p>  <p>1 Fixação 1 Fixation 1 Fixation</p>			
<p style="text-align: center;">$1,60 < L \leq 2,40 \text{ m}$</p>  <p>2 Fixações 2 Fixations 2 Fixations</p>			
<p style="text-align: center;">$2,40 < L \leq 3,20 \text{ m}$</p>  <p>3 Fixações 3 Fixations 3 Fixations</p>			
<p style="text-align: center;">$L > 3,20\text{m}$</p> <p>1 Fixação a mais por cada troço suplementar de 0,8m 1 Extra fixation for each additional section of 0,8m 1 Fixation plus pour chaque section supplémentaire de 0,8m</p>			



NU.MA Unipessoal Lda | Fotografia Ivo Tavares

VIII

PRÉ-AROS
PRE-FRAMES | PRÉ-CADRES

RELAÇÃO DE PERFIS PRÉ-AROS
PRE-FRAME PROFILES LIST
LISTE DES PROFILÉS PRÉ-CADRES

SO 89

(bite)
(bead | parclose)

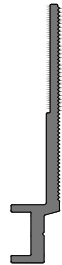

SO 98

pré-aro 1 rail
1 rail pre-frame profile | profilé pré-cadres 1 rail

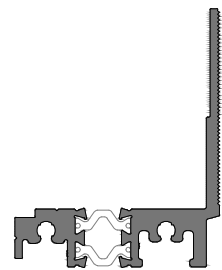

SO 90

(pré-aro 2 rail)
(2 rail pre-frame profile | profilé pré-cadres 2 rail)

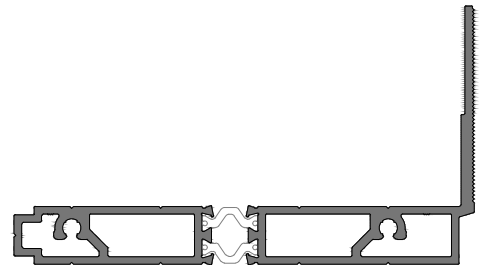

SO 91

(pré-aro 2 rail)
(2 rail pre-frame profile | profilé pré-cadres 2 rail)



SO 92

(pré-aro 3 rail)
(3 rail pre-frame profile | profilé pré-cadres 3 rail)

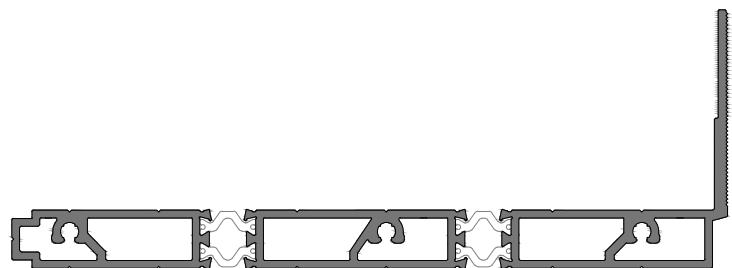

SO 93

(pré-aro 3 rail)
(3 rail pre-frame profile | profilé pré-cadres 3 rail)



RELAÇÃO DE PERFIS SOLEIRA
SILLS PROFILES LIST
LISTE DES PROFILÉS DE SEUILS

SO 80

(soleira 1-rail para caleira)
(1-rail sill for drainage gutter | seuil 1-rail pour gouttière de sol)



SO 82

(soleira 2-rail para caleira)
(2-rail sill for drainage gutter | seuil 2-rail pour gouttière de sol)



SO 84

(soleira 3-rail para caleira)
(3-rail sill for drainage gutter | seuil 3-rail pour gouttière de sol)

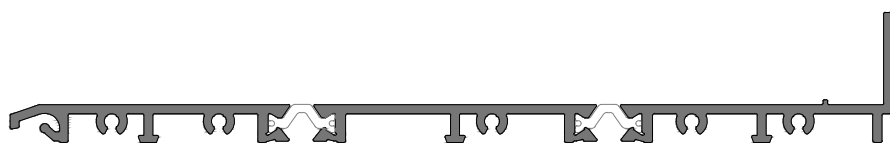

SO 83

(soleira 4-rail para caleira)
(4-rail sill for drainage gutter | seuil 4-rail pour gouttière de sol)

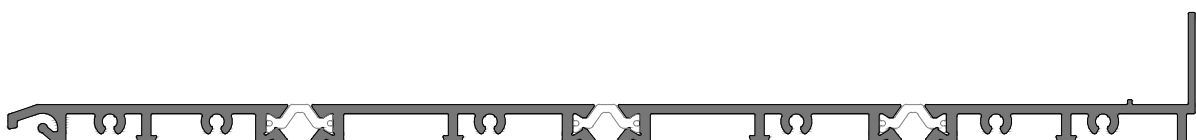

ACESSÓRIOS
ACCESSORIES
ACCESSOIRES

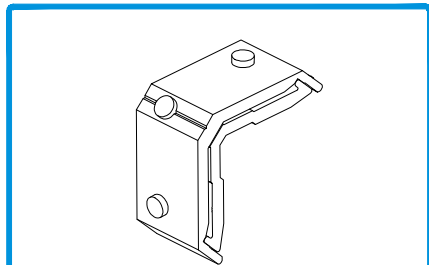

Para os perfis SO 11, SO 12, SO 13, SO 21, SO 22,
SO 23, SO 90, SO 91, SO 92, SO 93, SO 68 e SO 69

205172

ESQUADRO 18-2210-D

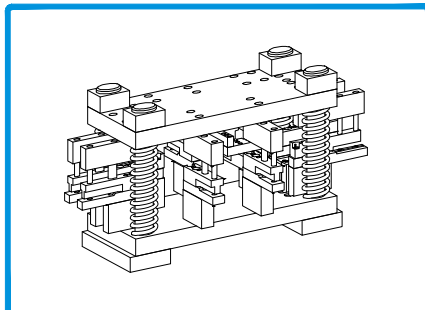

408175

CORTANTE ESQUADROS OS Nº2

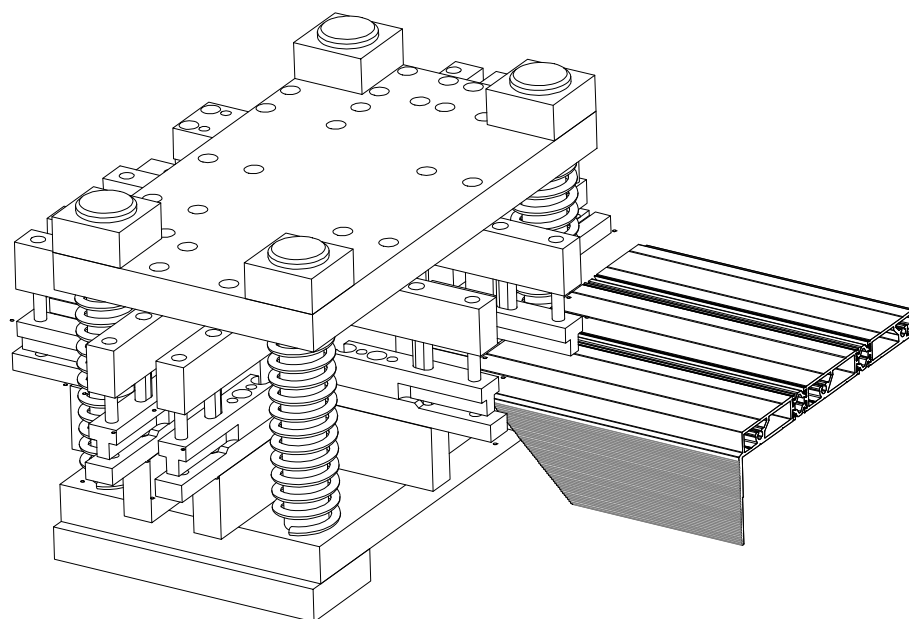

CORTANTE ESQUADROS OS Nº2
N. 2 OS CORNER CLEATS PUNCHING TOOL
POINÇON ÉQUERRES OS N.2

APLICAÇÃO DE PRÉ AROS - 1-RAIL

PRE-FRAMES APPLICATION - 1-RAIL | APPLICATION DES PRÉ-CADRES - 1-RAIL

APLICAÇÃO PERIMETRAL

PERIMETER APPLICATION | APPLICATION PÉRIMÉTRALE

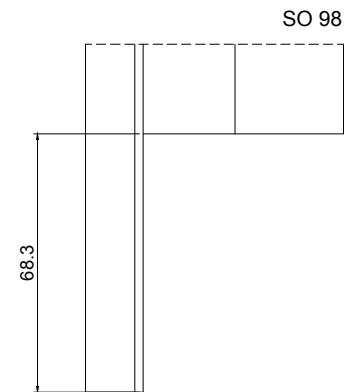
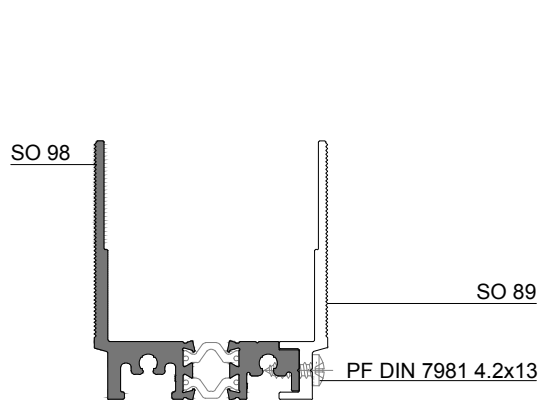
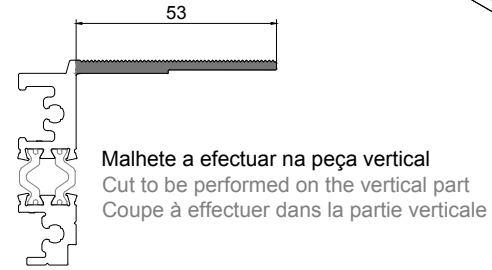
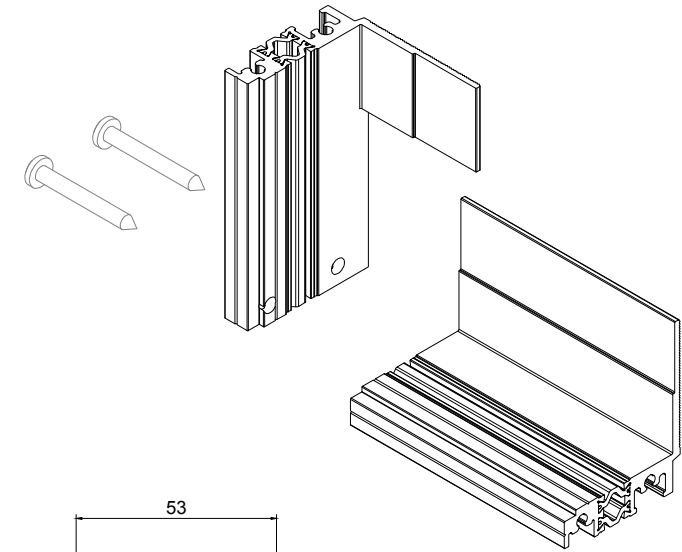
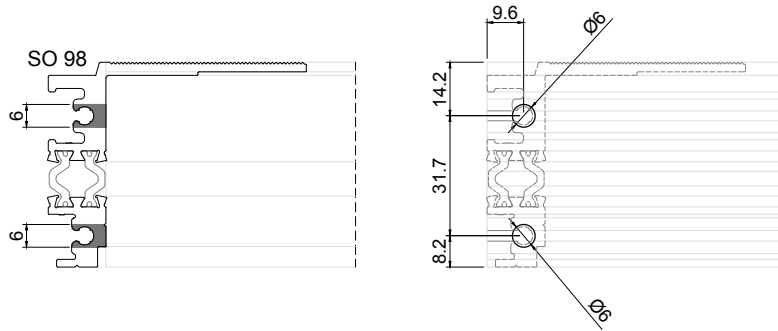
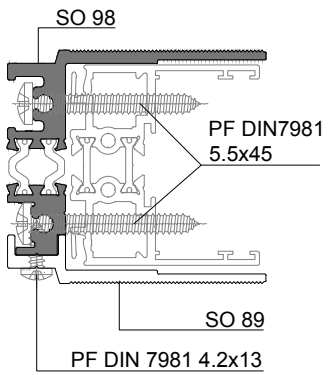

APLICAÇÃO DE PRÉ AROS - 1-RAIL

PRE-FRAMES APPLICATION - 1-RAIL | APPLICATION DES PRÉ-CADRES - 1-RAIL

APLICAÇÃO PRÉ-ARO NAS LATERAIS + PERFIL DE SOLEIRA

PRE-FRAMES ON LATERALS + SILL PROFILE APPLICATION | PRÉ-CADRES DANS LES LATÉRAUX + PROFILÉ DE SEUIL

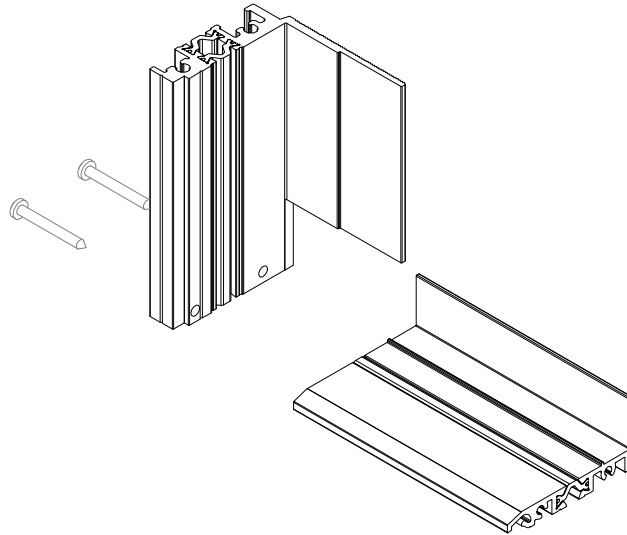

Malhete a efectuar na peça vertical

Cut to be performed on the vertical part
Coupe à effectuer dans la partie verticale

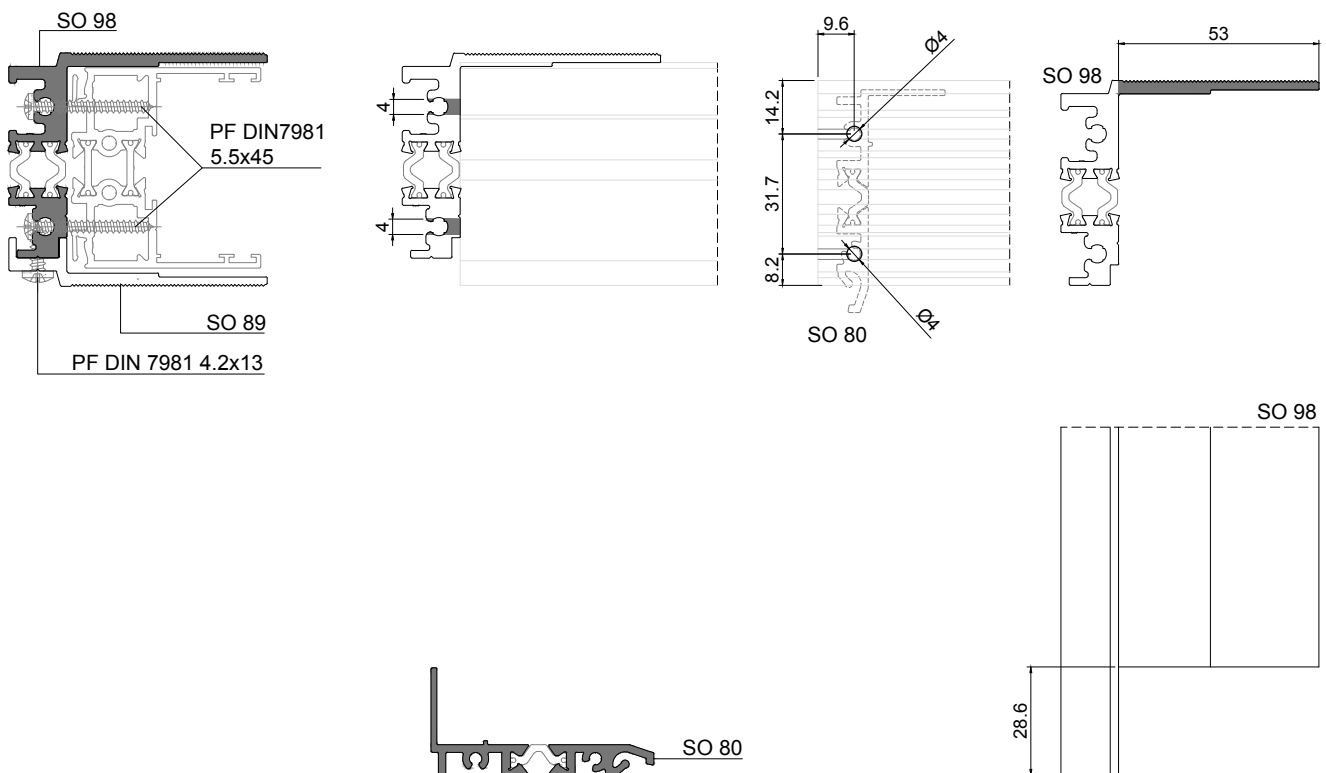

APLICAÇÃO DE PRÉ AROS - 2-RAIL

PRE-FRAMES APPLICATION - 2-RAIL | APPLICATION DES PRÉ-CADRES - 2-RAIL

LIGAÇÃO A 90° COM MALHETE NA PEÇA VERTICAL

90° CONNECTION WITH CUT ON THE VERTICAL PART | LIAISON À 90° AVEC CUP DANS LA PARTIE VERTICALE

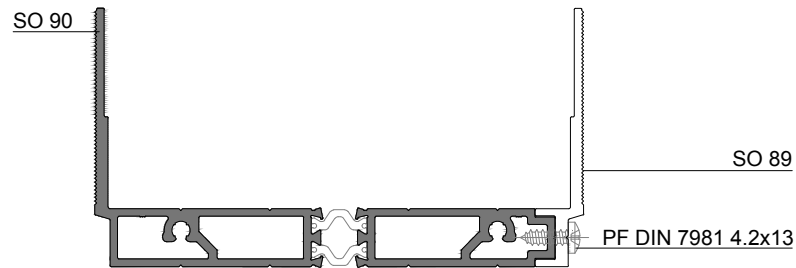
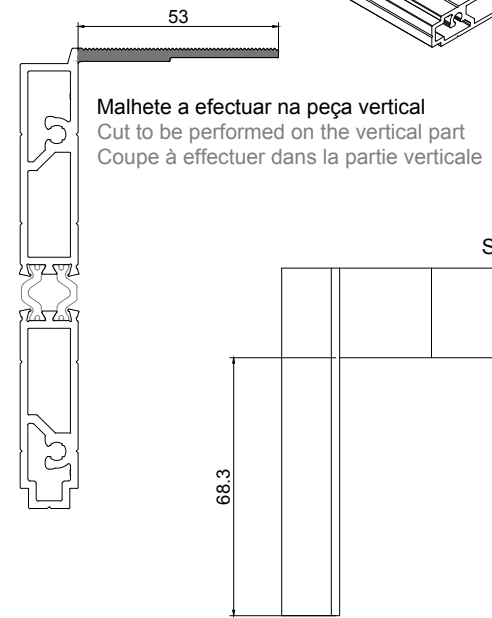
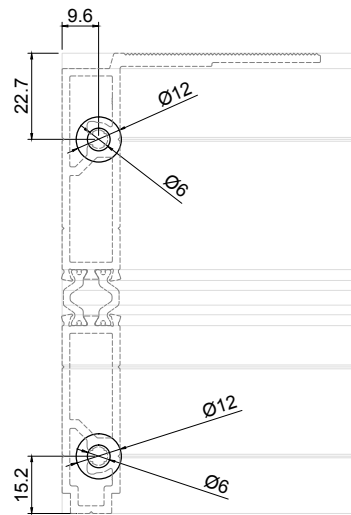
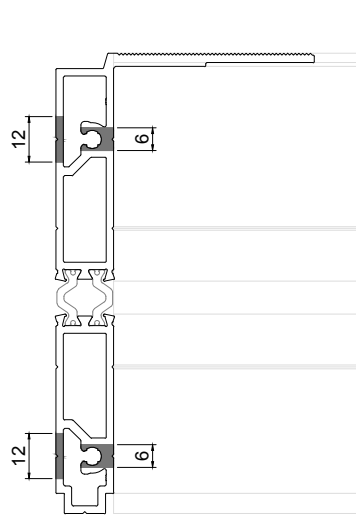
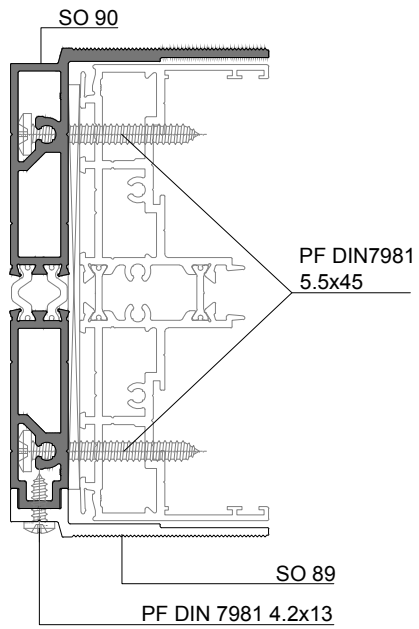
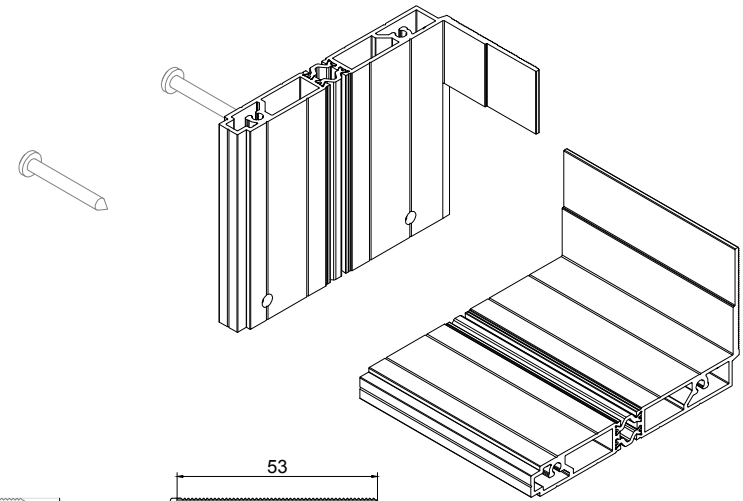

APLICAÇÃO DE PRÉ AROS - 2-RAIL

PRE-FRAMES APPLICATION - 2-RAIL | APPLICATION DES PRÉ-CADRES - 2-RAIL

LIGAÇÃO A 90° SEM MALHETE

90° CONNECTION WITHOUT CUTS | LIAISON À 90° SANS CUPS

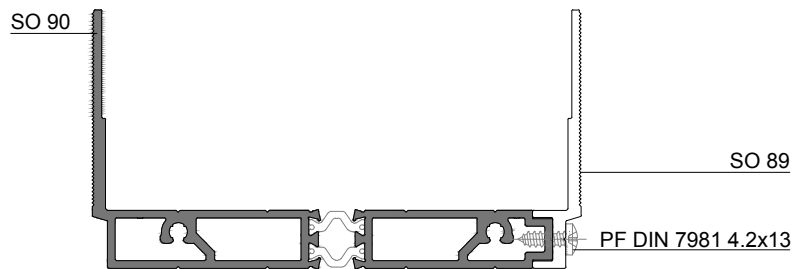
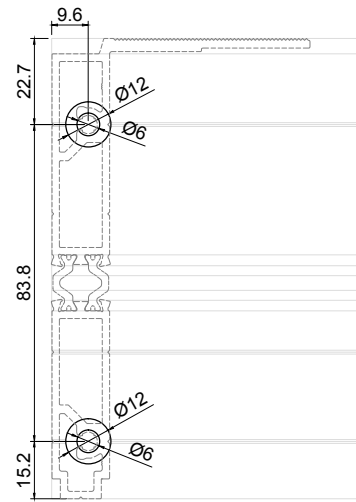
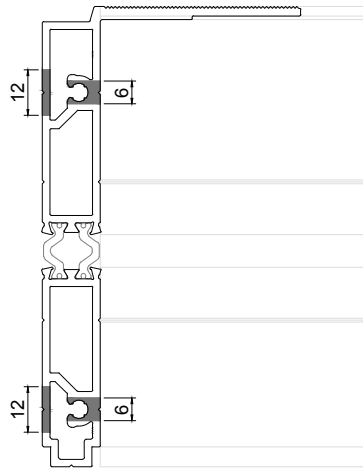
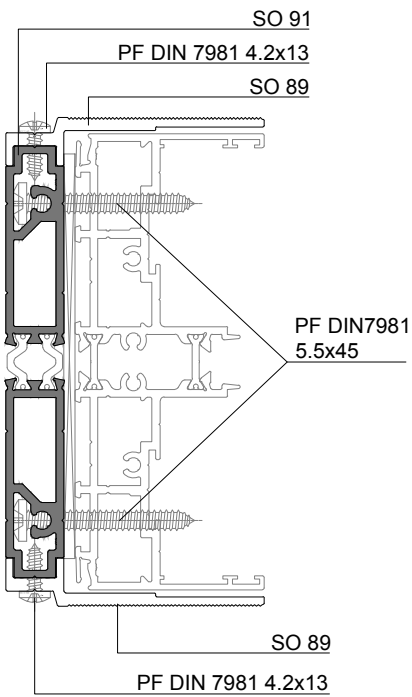
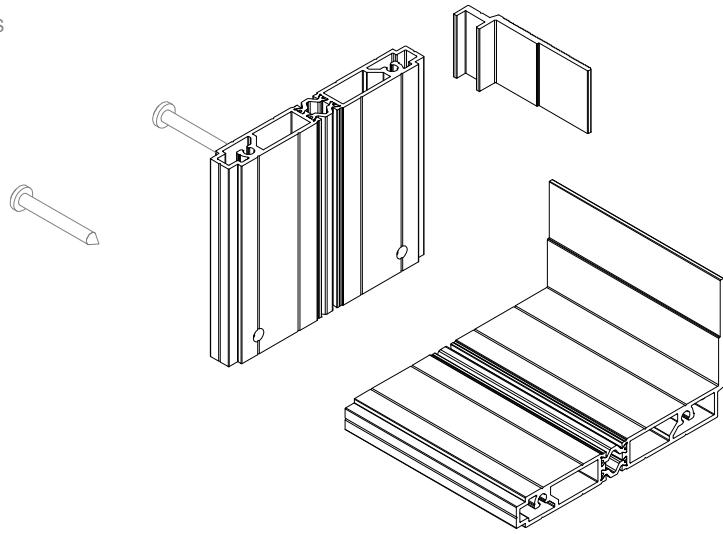

APLICAÇÃO DE PRÉ AROS - 2-RAIL

PRE-FRAMES APPLICATION - 2-RAIL | APPLICATION DES PRÉ-CADRES - 2-RAIL

LIGAÇÃO A 45° COM ESQUADRO

45° CONNECTION WITH CORNER CLEATS | LIAISON À 45° AVEC EQUÉRRES

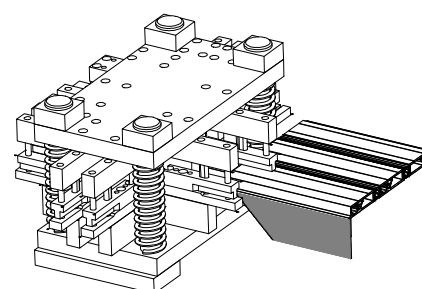
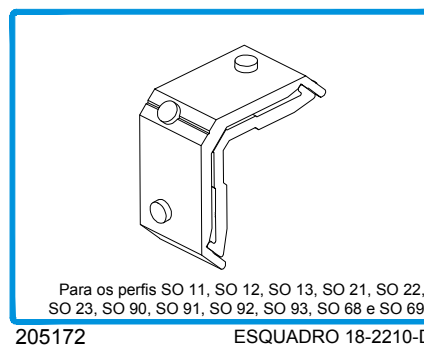
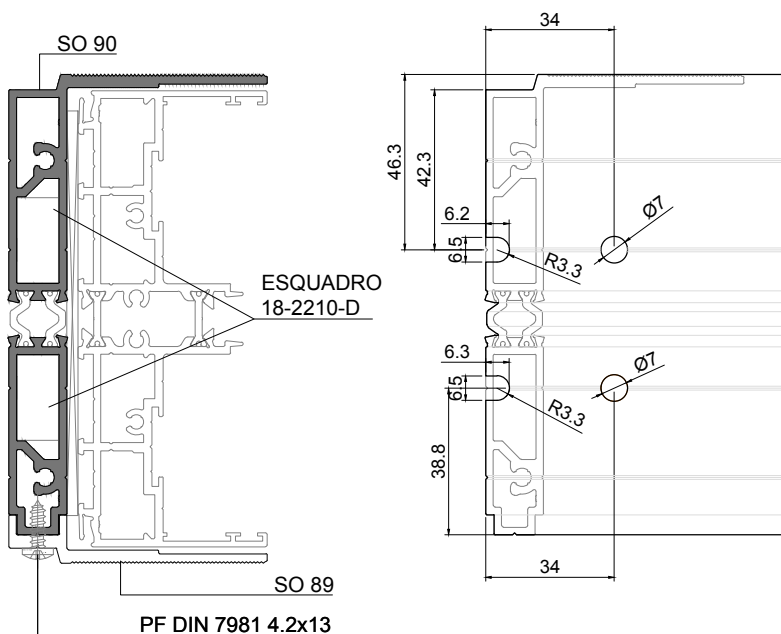
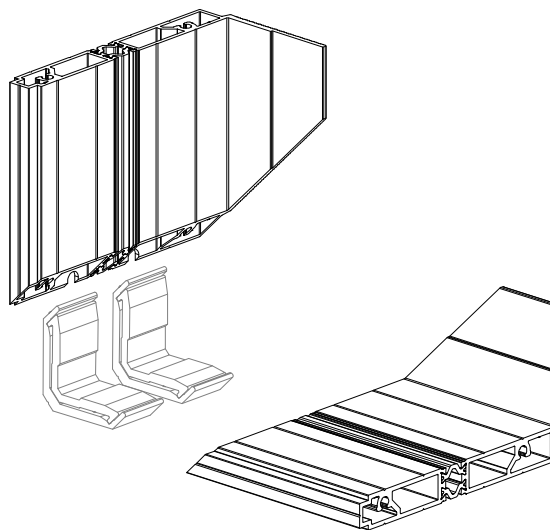

CORTANTE ESQUADROS OS Nº2
N. 2 OS CORNER CLEATS PUNCHING TOOL
POINÇON ÉQUERRES OS N.2

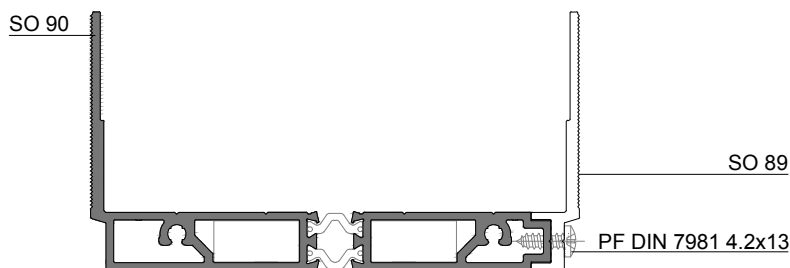

APLICAÇÃO DE PRÉ AROS - 2-RAIL

PRE-FRAMES APPLICATION - 2-RAIL | APPLICATION DES PRÉ-CADRES - 2-RAIL

LIGAÇÃO A 45° COM ESQUADRO

45° CONNECTION WITH CORNER CLEATS | LIAISON À 45° AVEC EQUÉRRES

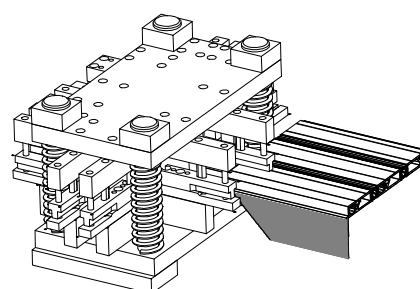
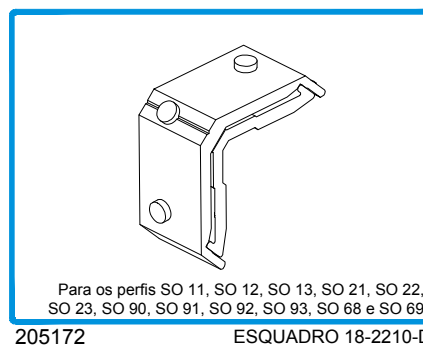
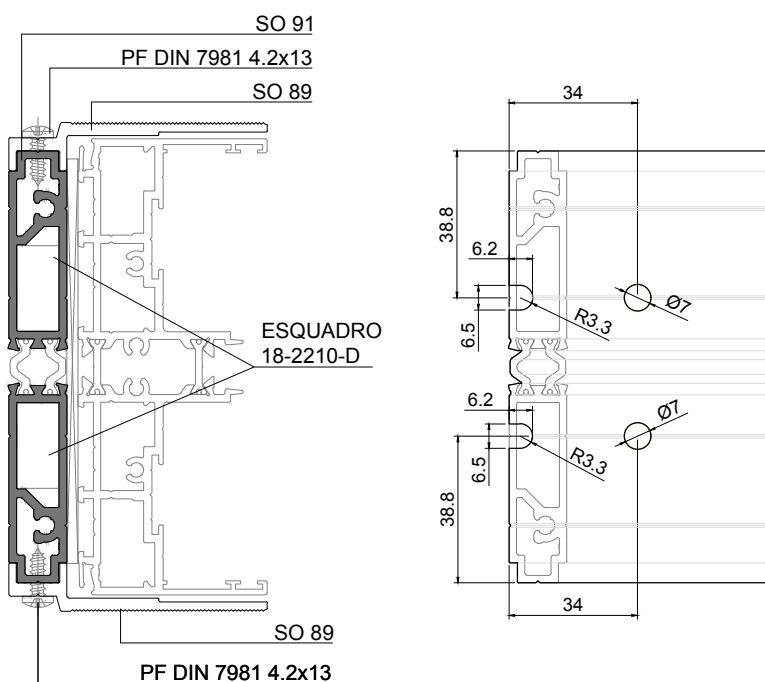
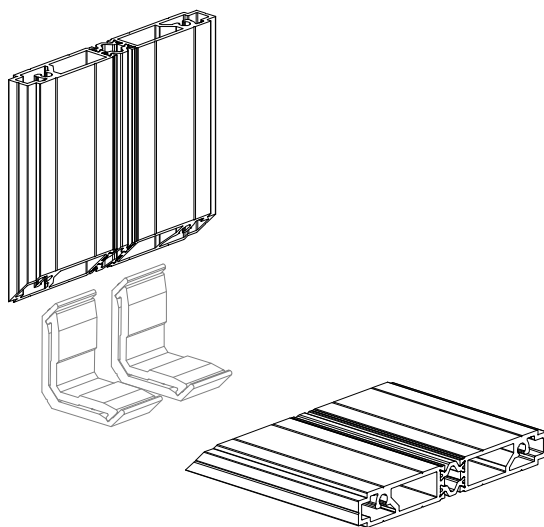

CORTANTE ESQUADROS OS Nº2
N. 2 OS CORNER CLEATS PUNCHING TOOL
POINÇON ÉQUERRES OS N.2

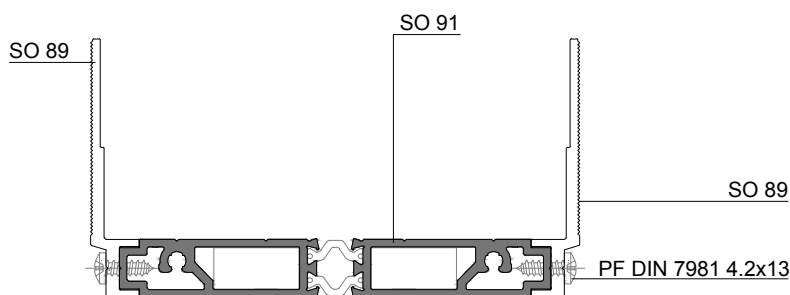

APLICAÇÃO DE PRÉ AROS - 2-RAIL

PRE-FRAMES APPLICATION - 2-RAIL | APPLICATION DES PRÉ-CADRES - 2-RAIL

LIGAÇÃO A 45° COM PARAFUSOS

45° CONNECTION WITH SCREWS | LIAISON À 45° AVEC VIS

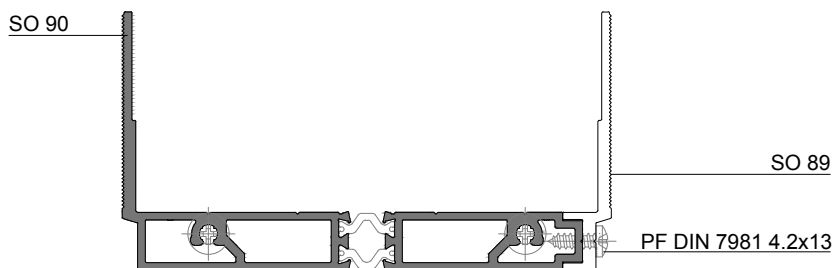
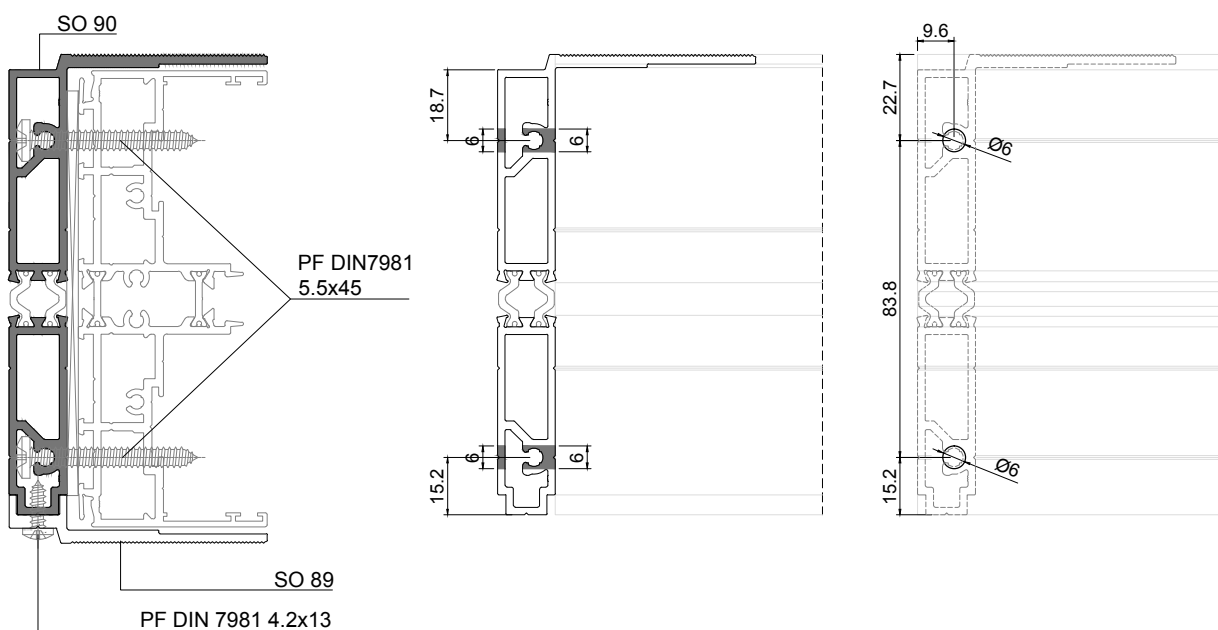
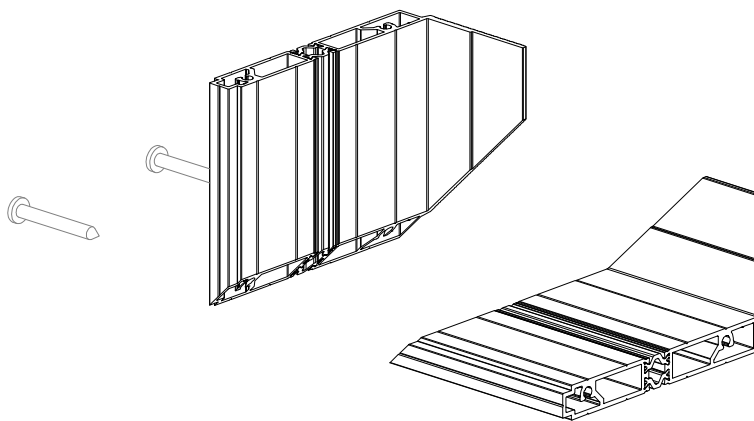

APLICAÇÃO DE PRÉ AROS - 2-RAIL

PRE-FRAMES APPLICATION - 2-RAIL | APPLICATION DES PRÉ-CADRES - 2-RAIL

APLICAÇÃO PRÉ-ARO EMALHETADO NAS LATERAIS + PERFIL DE SOLEIRA

CUTED PRE-FRAMES ON LATERALS + SILL PROFILE APPLICATION | PRÉ-CADRES COUPÉS DANS LES LATÉRAUX + PROFILÉ DE SEUIL

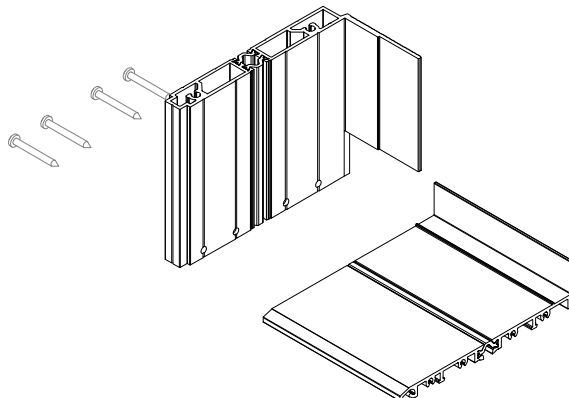

Malhete a efectuar na peça vertical
Cut to be performed on the vertical part
Coupe à effectuer dans la partie verticale

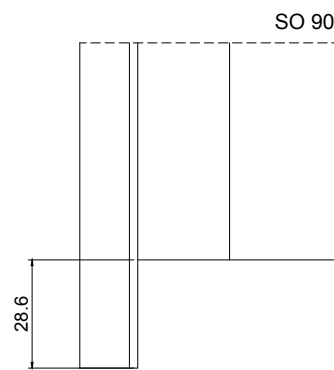
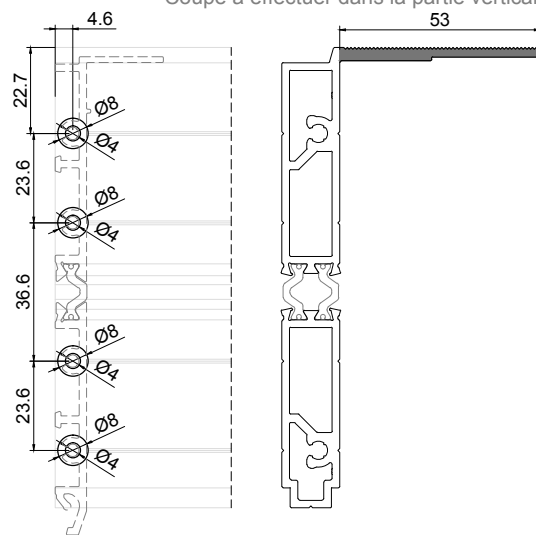
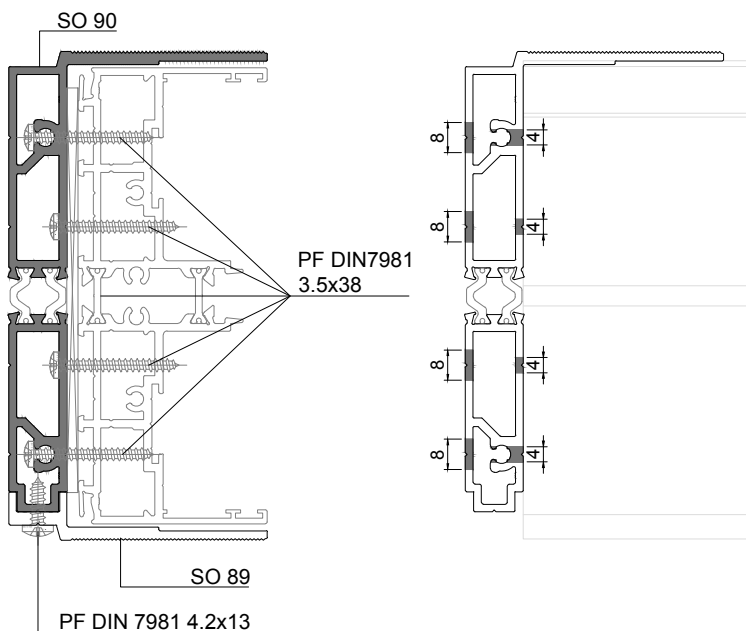

APLICAÇÃO DE PRÉ AROS - 2-RAIL

PRE-FRAMES APPLICATION - 2-RAIL | APPLICATION DES PRÉ-CADRES - 2-RAIL

LIGAÇÃO A 90° SEM MALHETE + PERFIL DE SOLEIRA

90° CONNECTION WITHOUT CUTS + SILL PROFILE APPLICATION | LIAISON À 90° SANS CUPS + PROFILÉ DE SEUIL

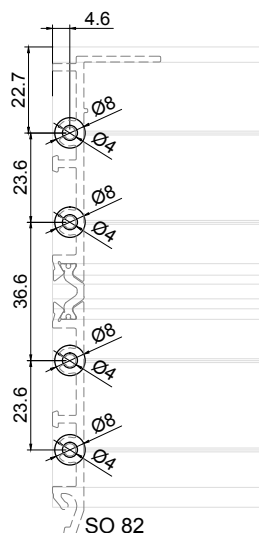
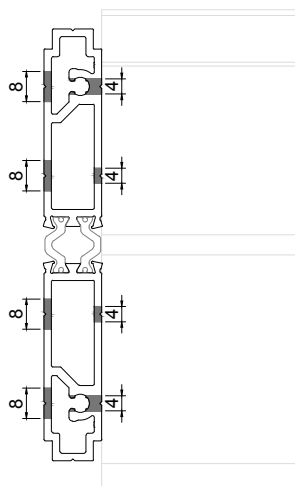
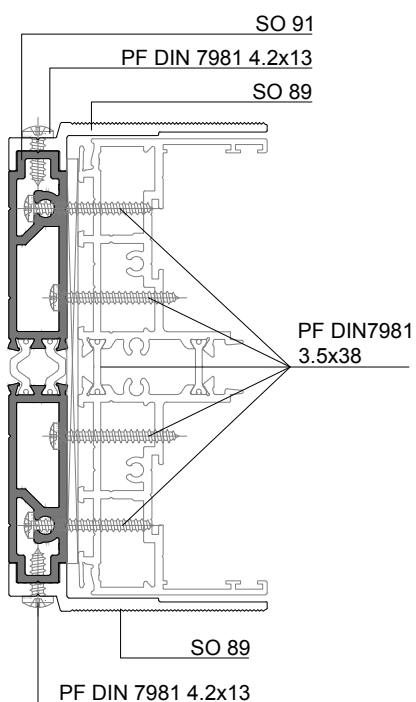
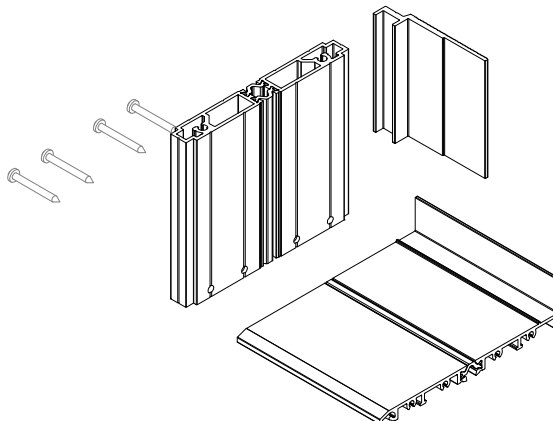

APLICAÇÃO DE PRÉ AROS - 3-RAIL

PRE-FRAMES APPLICATION - 3-RAIL | APPLICATION DES PRÉ-CADRES - 3-RAIL

LIGAÇÃO A 90° SEM MALHETE

90° CONNECTION WITHOUT CUTS | LIAISON À 90° SANS CUPS

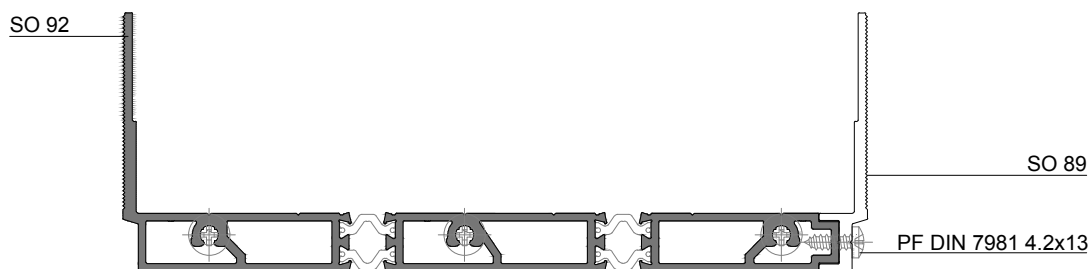
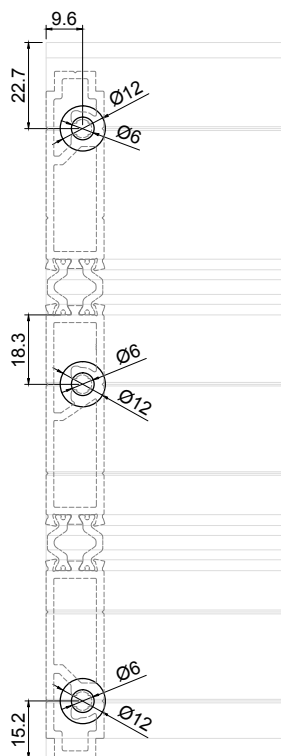
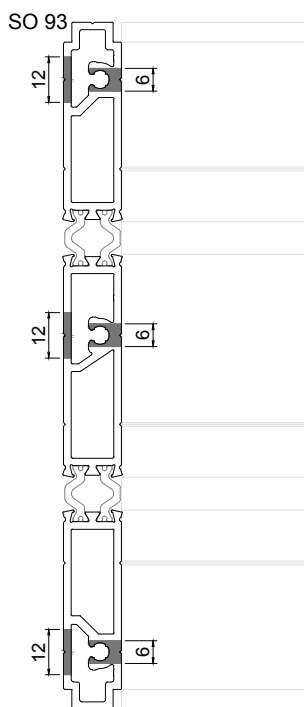
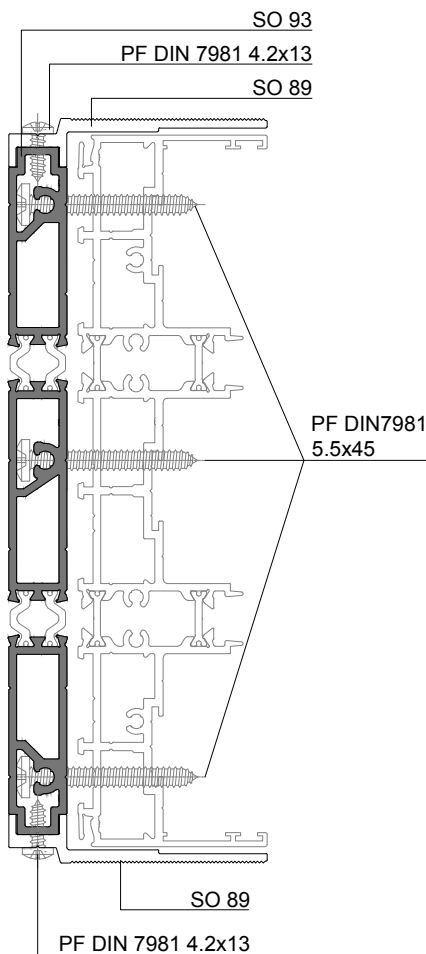
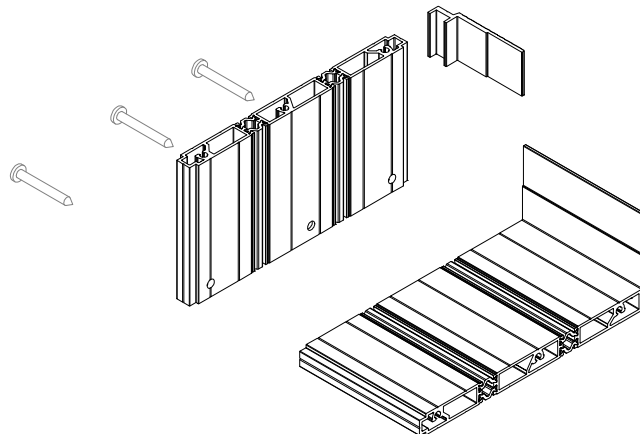

APLICAÇÃO DE PRÉ AROS - 3-RAIL

PRE-FRAMES APPLICATION - 3-RAIL | APPLICATION DES PRÉ-CADRES - 3-RAIL

LIGAÇÃO A 45° COM ESQUADRO

45° CONNECTION WITH CORNER CLEATS | LIAISON À 45° AVEC EQUÉRRES

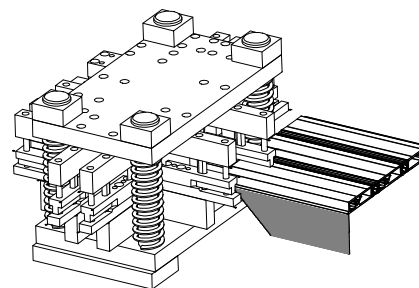
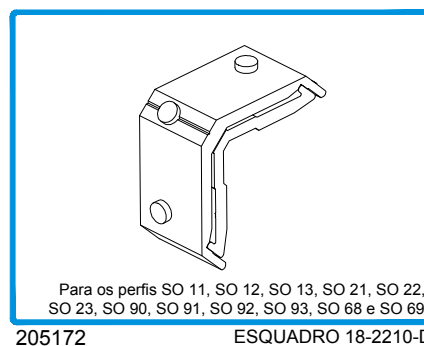
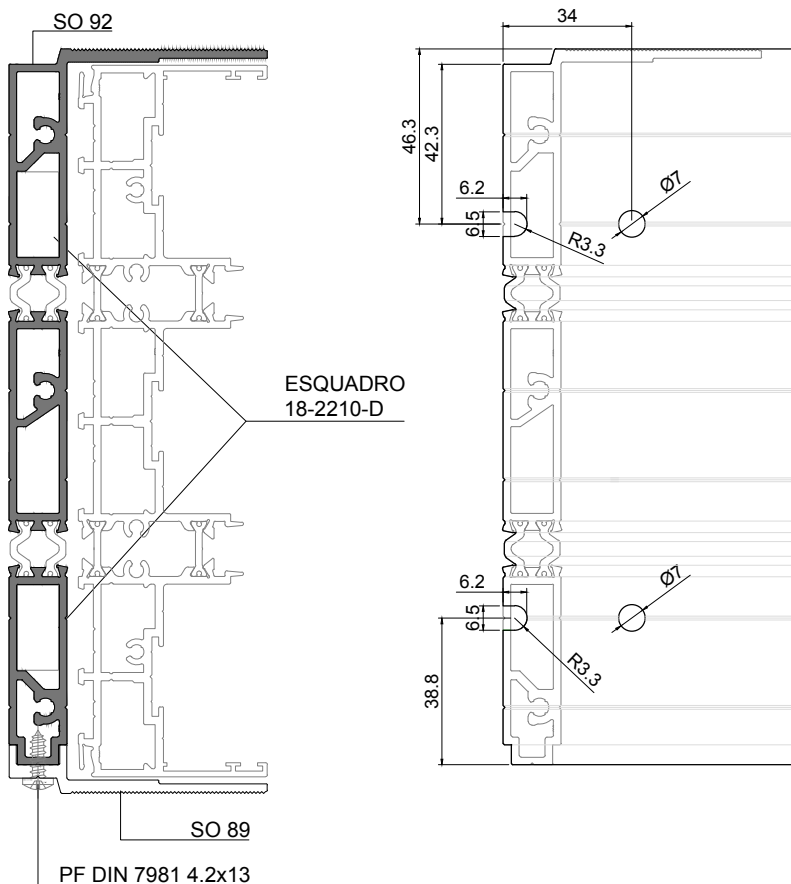
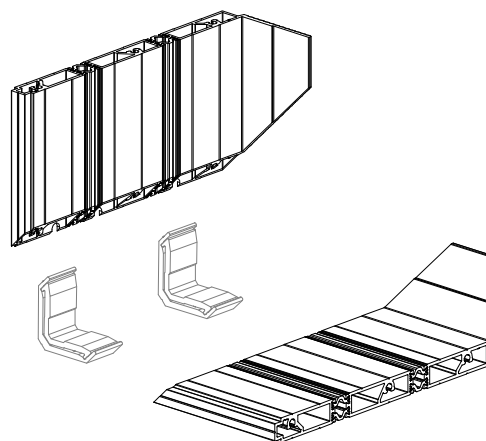

CORTANTE ESQUADROS OS Nº2
N. 2 OS CORNER CLEATS PUNCHING TOOL
POINÇON ÉQUERRES OS N.2

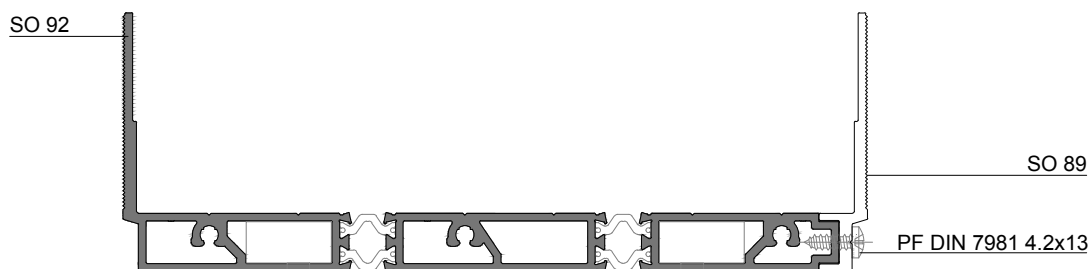

APLICAÇÃO DE PRÉ AROS - 3-RAIL

PRE-FRAMES APPLICATION - 3-RAIL | APPLICATION DES PRÉ-CADRES - 3-RAIL

LIGAÇÃO A 45° COM ESQUADRO

45° CONNECTION WITH CORNER CLEATS | LIAISON À 45° AVEC EQUÉRRES

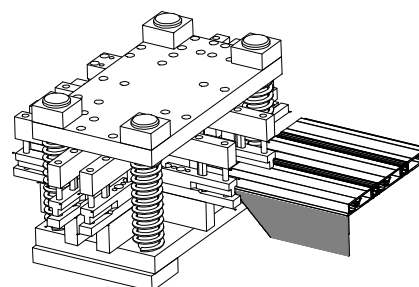
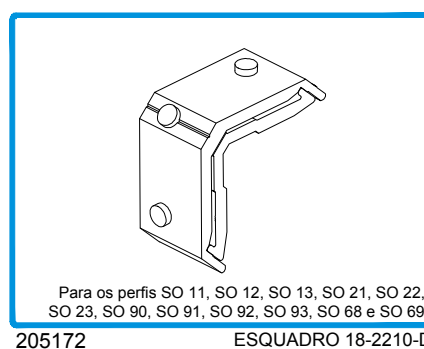
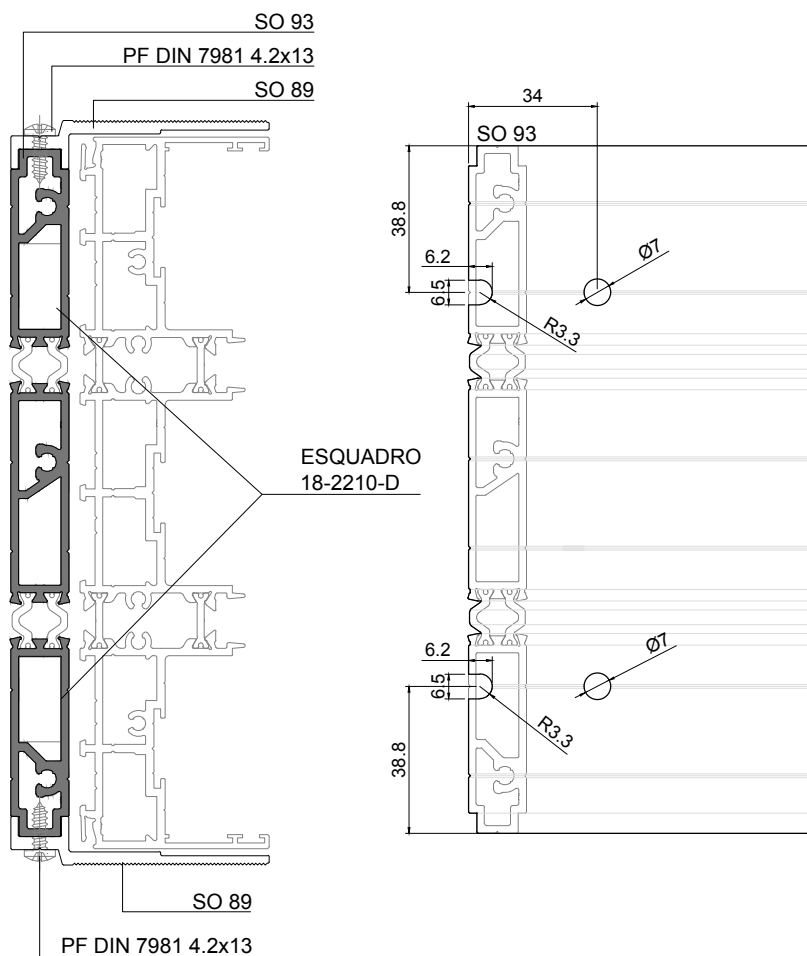
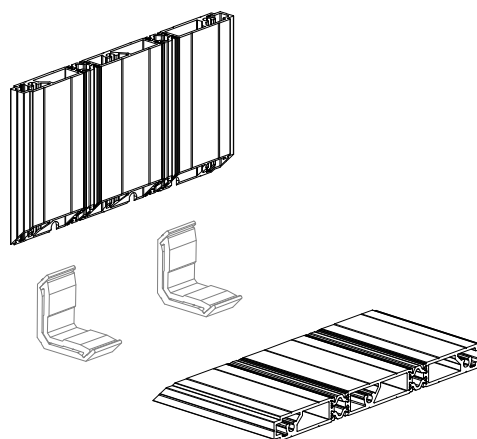

CORTANTE ESQUADROS OS Nº2
N. 2 OS CORNER CLEATS PUNCHING TOOL
POINÇON ÉQUERRES OS N.2

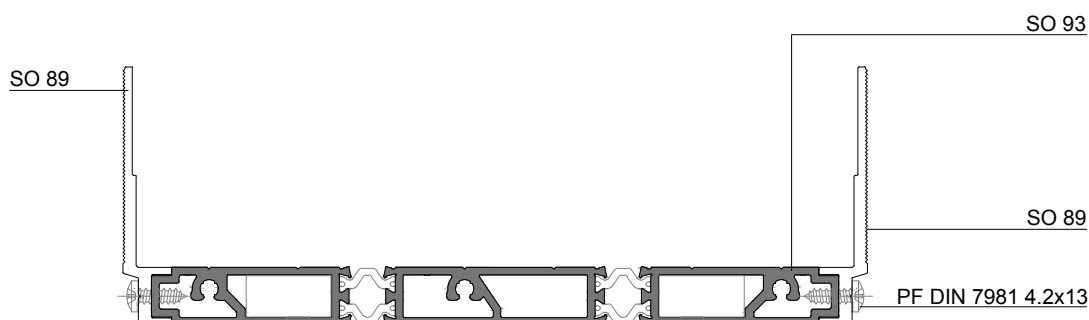

APLICAÇÃO DE PRÉ AROS - 3-RAIL

PRE-FRAMES APPLICATION - 3-RAIL | APPLICATION DES PRÉ-CADRES - 3-RAIL

LIGAÇÃO A 45° COM PARAFUSOS

45° CONNECTION WITH SCREWS | LIAISON À 45° AVEC VIS

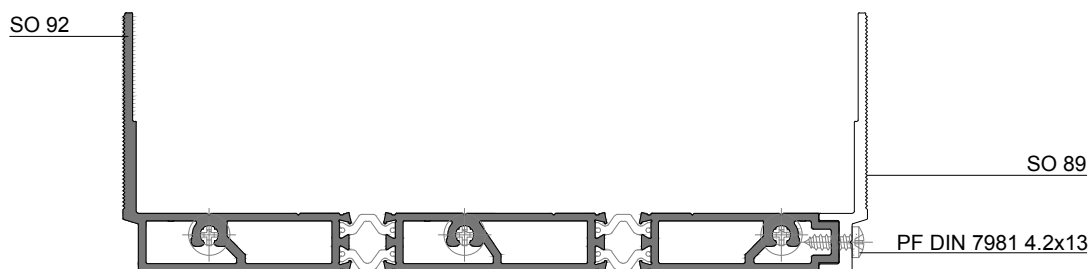
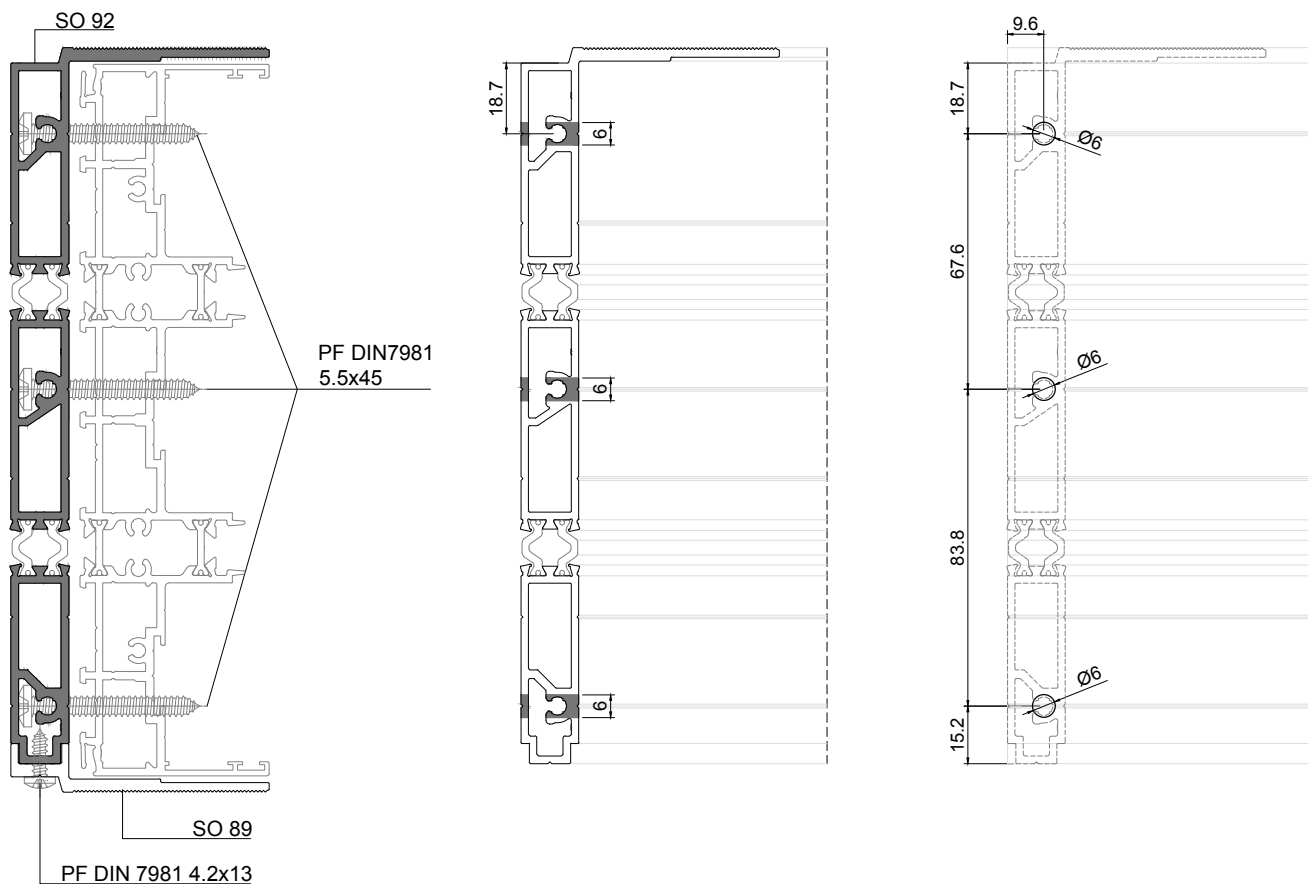
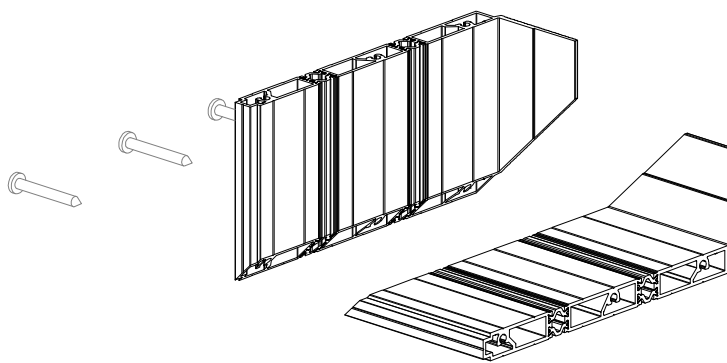

APLICAÇÃO DE PRÉ AROS - 3-RAIL

PRE-FRAMES APPLICATION - 3-RAIL | APPLICATION DES PRÉ-CADRES - 3-RAIL

APLICAÇÃO PRÉ-ARO EMALHETADO NAS LATERAIS + PERFIL DE SOLEIRA

CUTED PRE-FRAMES ON LATERALS + SILL PROFILE APPLICATION | PRÉ-CADRES COUPÉS DANS LES LATÉRAUX + PROFILÉ DE SEUIL

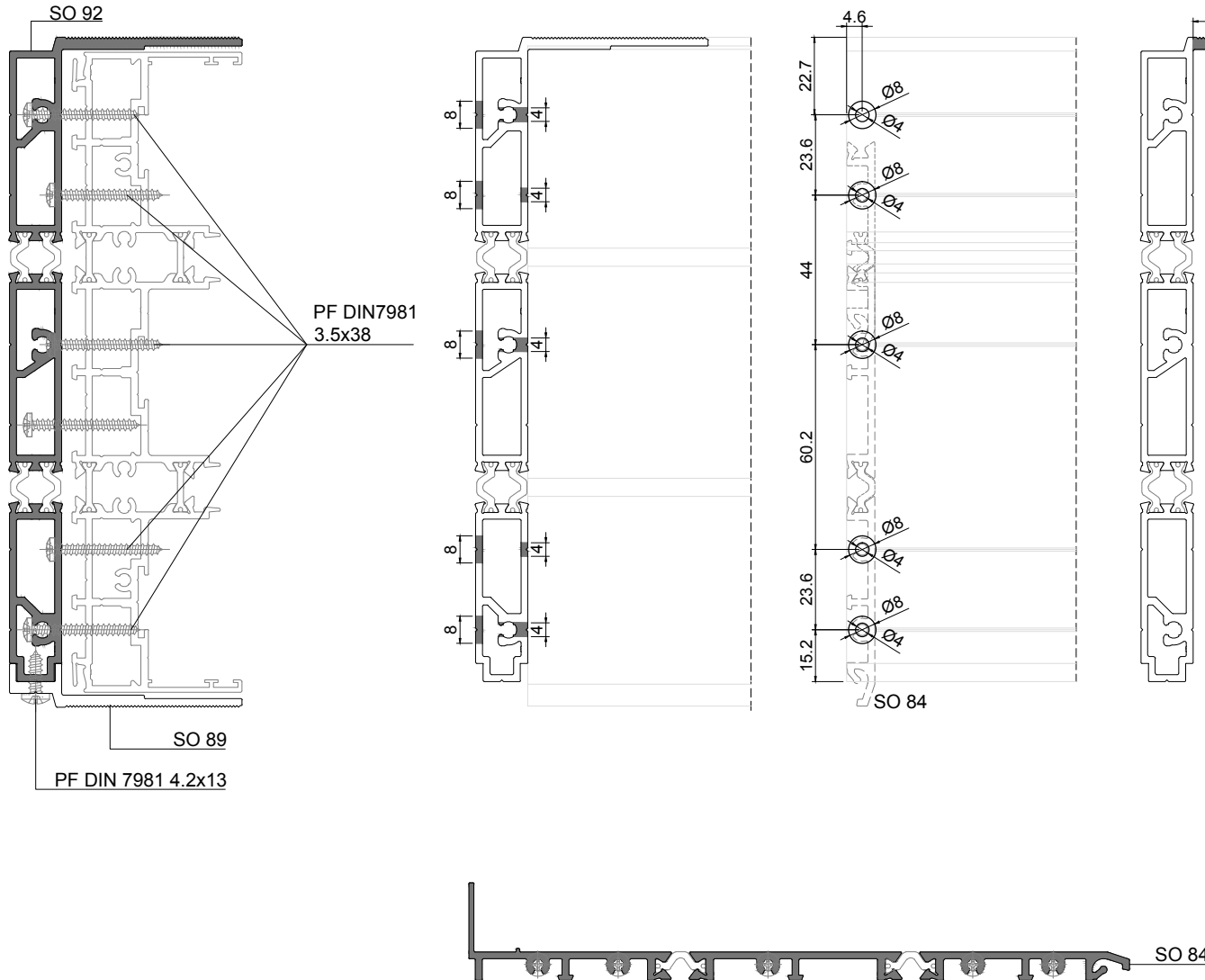
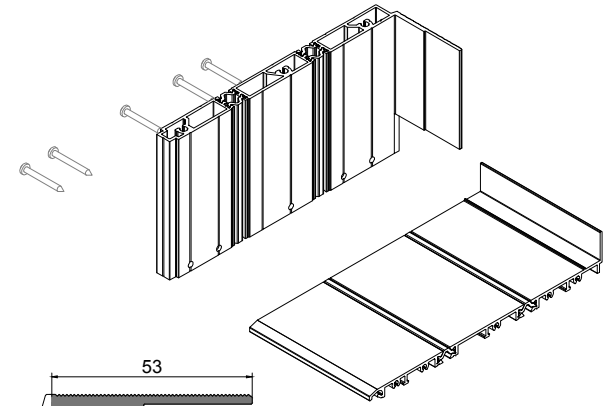

Malhete a efectuar na peça vertical
Cut to be performed on the vertical part
Coupe à effectuer dans la partie verticale

APLICAÇÃO DE PRÉ AROS - 3-RAIL

PRE-FRAMES APPLICATION - 3-RAIL | APPLICATION DES PRÉ-CADRES - 3-RAIL

LIGAÇÃO A 90° SEM MALHETE + PERFIL DE SOLEIRA

90° CONNECTION WITHOUT CUTS + SILL PROFILE APPLICATION | LIAISON À 90° SANS CUPS + PROFILÉ DE SEUIL

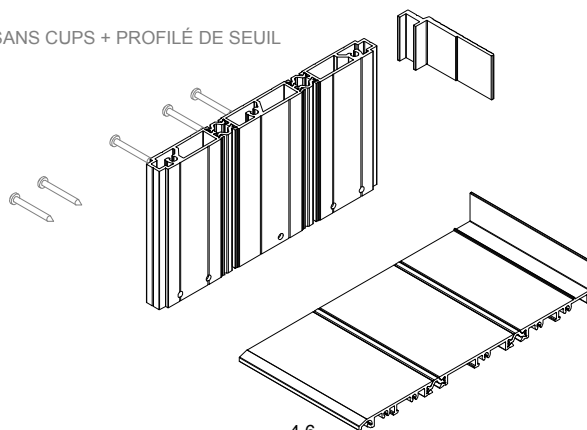

SO 93
PF DIN 7981 4.2x13
SO 89

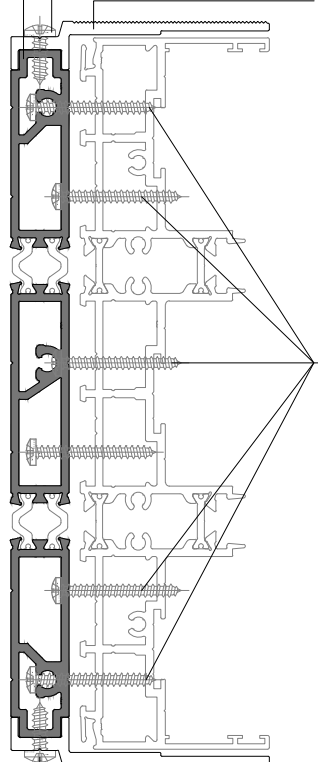

PF DIN7981
3.5x38

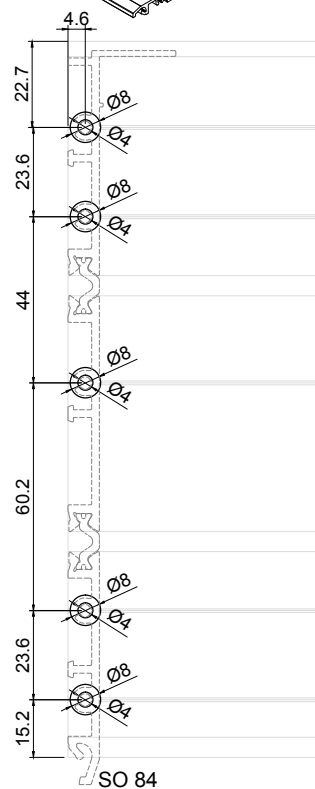
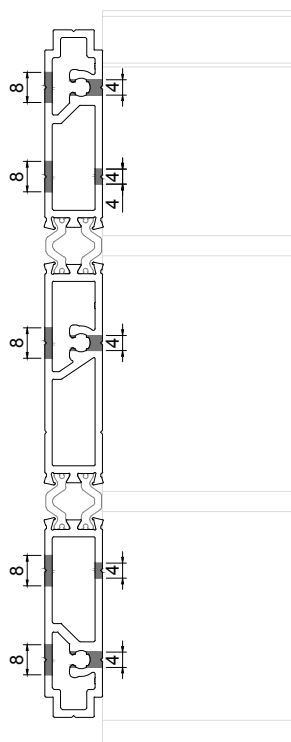

SO 89
PF DIN 7981 4.2x13



APLICAÇÃO DE PRÉ AROS - 4-RAIL

PRE-FRAMES APPLICATION - 4-RAIL | APPLICATION DES PRÉ-CADRES - 4-RAIL

LIGAÇÃO A 90° COM MALHETE NA PEÇA VERTICAL

90° CONNECTION WITH CUT ON THE VERTICAL PART | LIAISON À 90° AVEC CUP DANS LA PARTIE VERTICALE

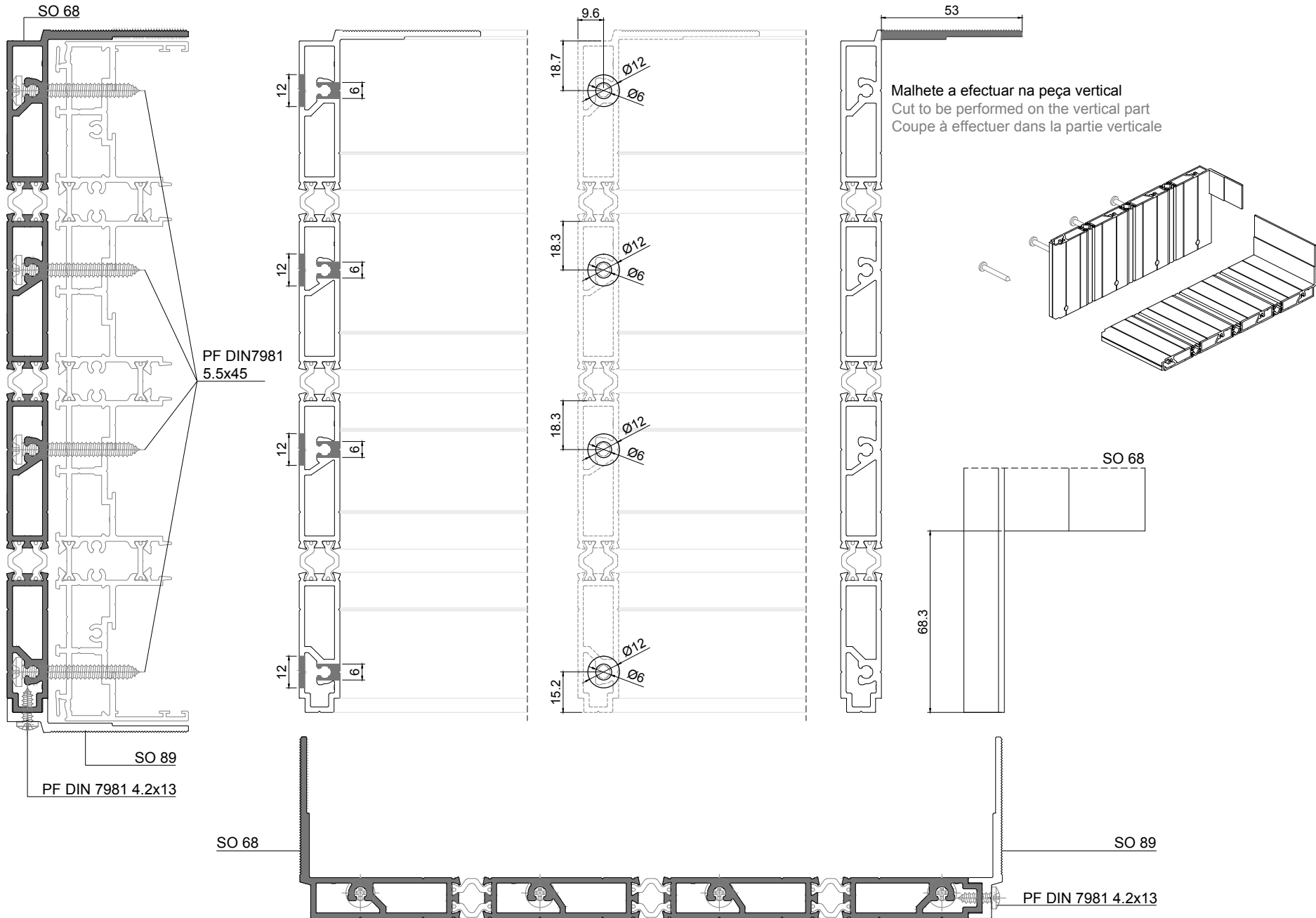

APLICAÇÃO DE PRÉ AROS - 4-RAIL

PRE-FRAMES APPLICATION - 4-RAIL | APPLICATION DES PRÉ-CADRES - 4-RAIL

LIGAÇÃO A 90° SEM MALHETE

90° CONNECTION WITHOUT CUTS | LIAISON À 90° SANS CUPS

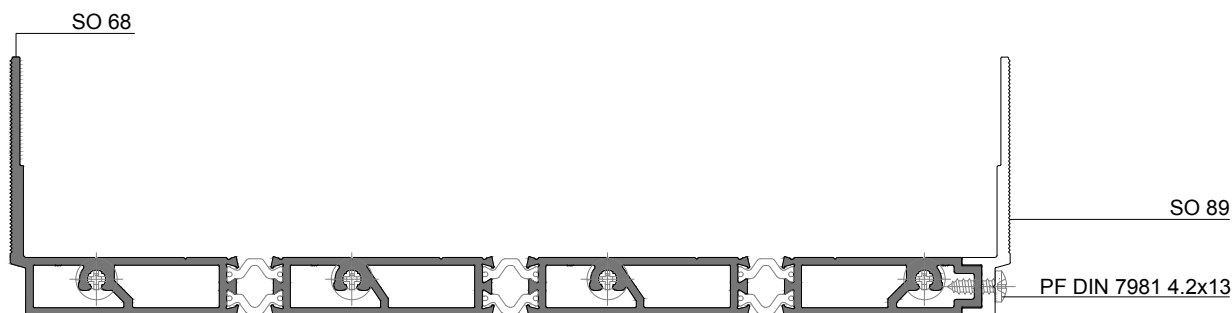
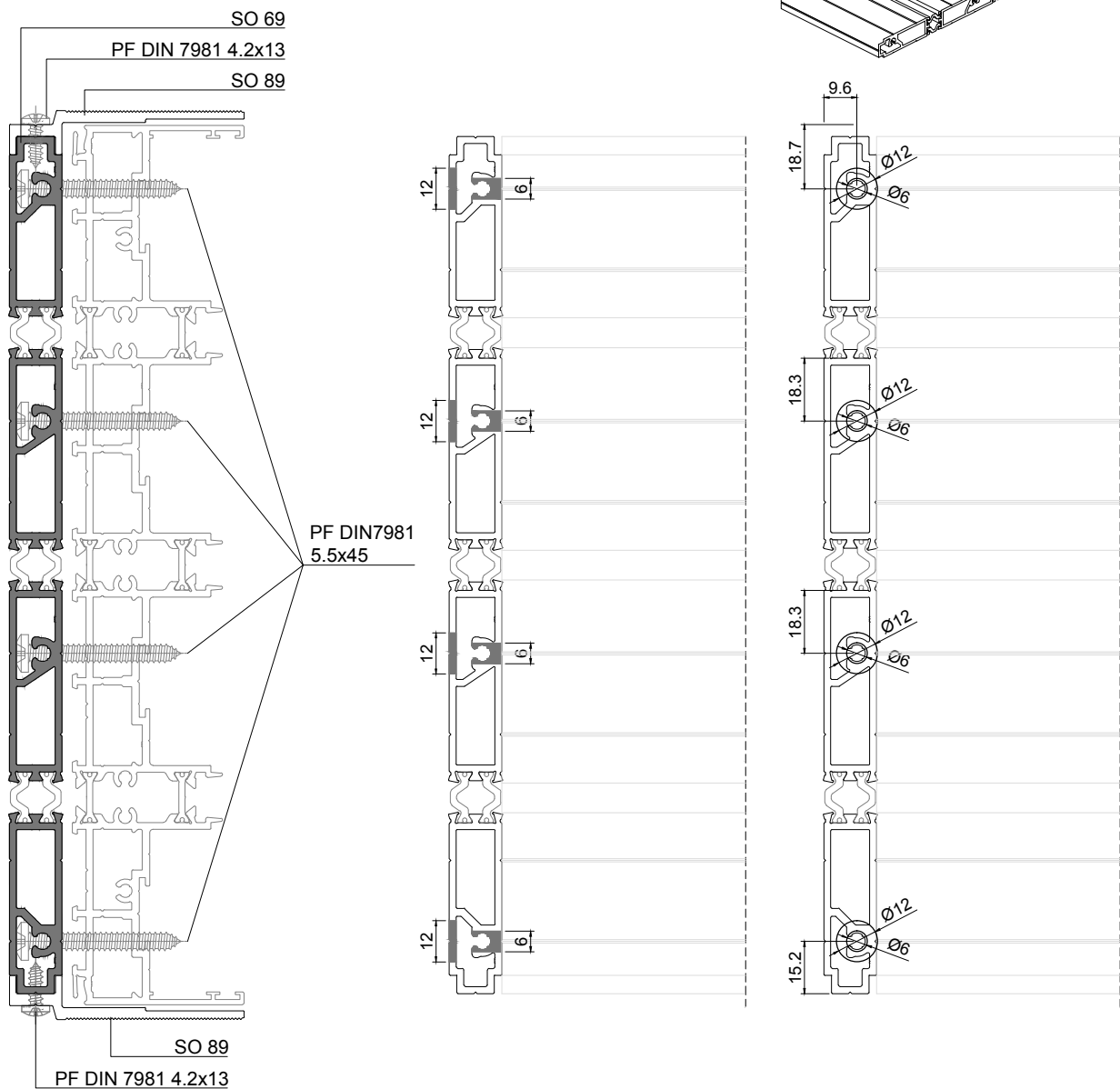
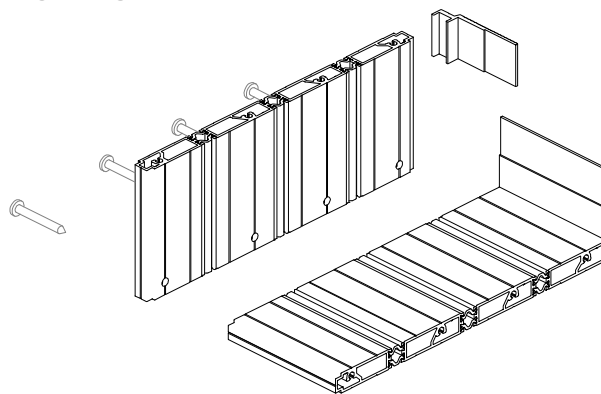

APLICAÇÃO DE PRÉ AROS - 4-RAIL

PRE-FRAMES APPLICATION - 4-RAIL | APPLICATION DES PRÉ-CADRES - 4-RAIL

LIGAÇÃO A 45° COM ESQUADRO

45° CONNECTION WITH CORNER CLEATS | LIAISON À 45° AVEC EQUÉRRES

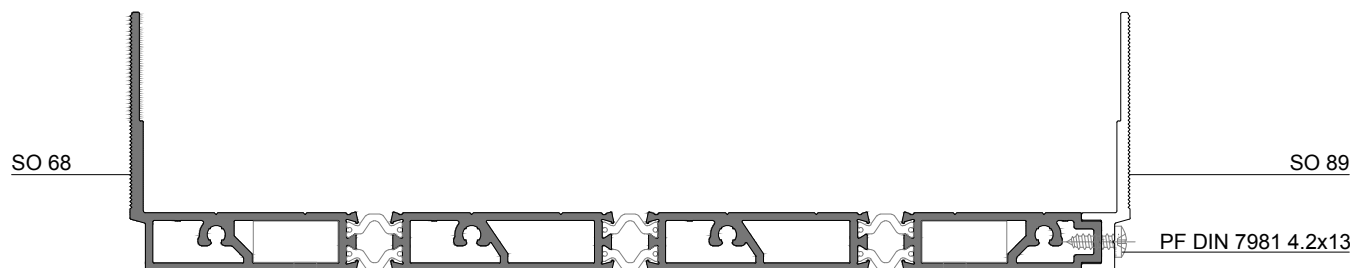
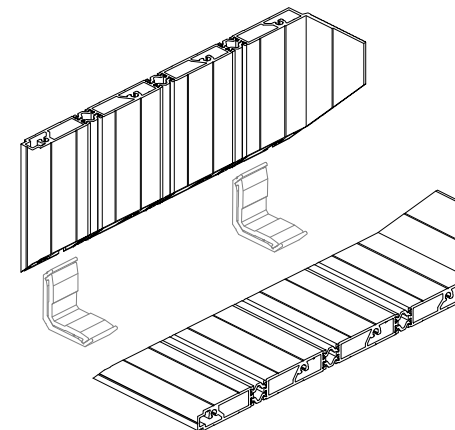
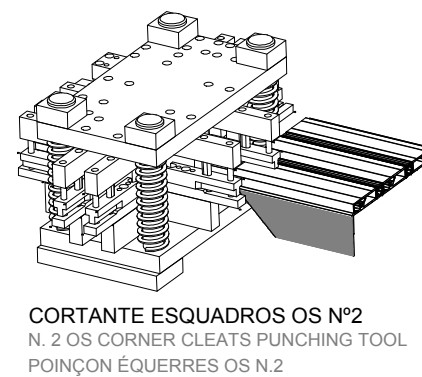
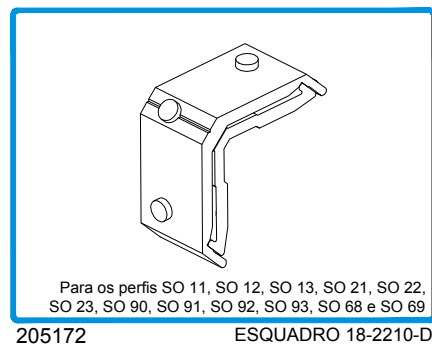
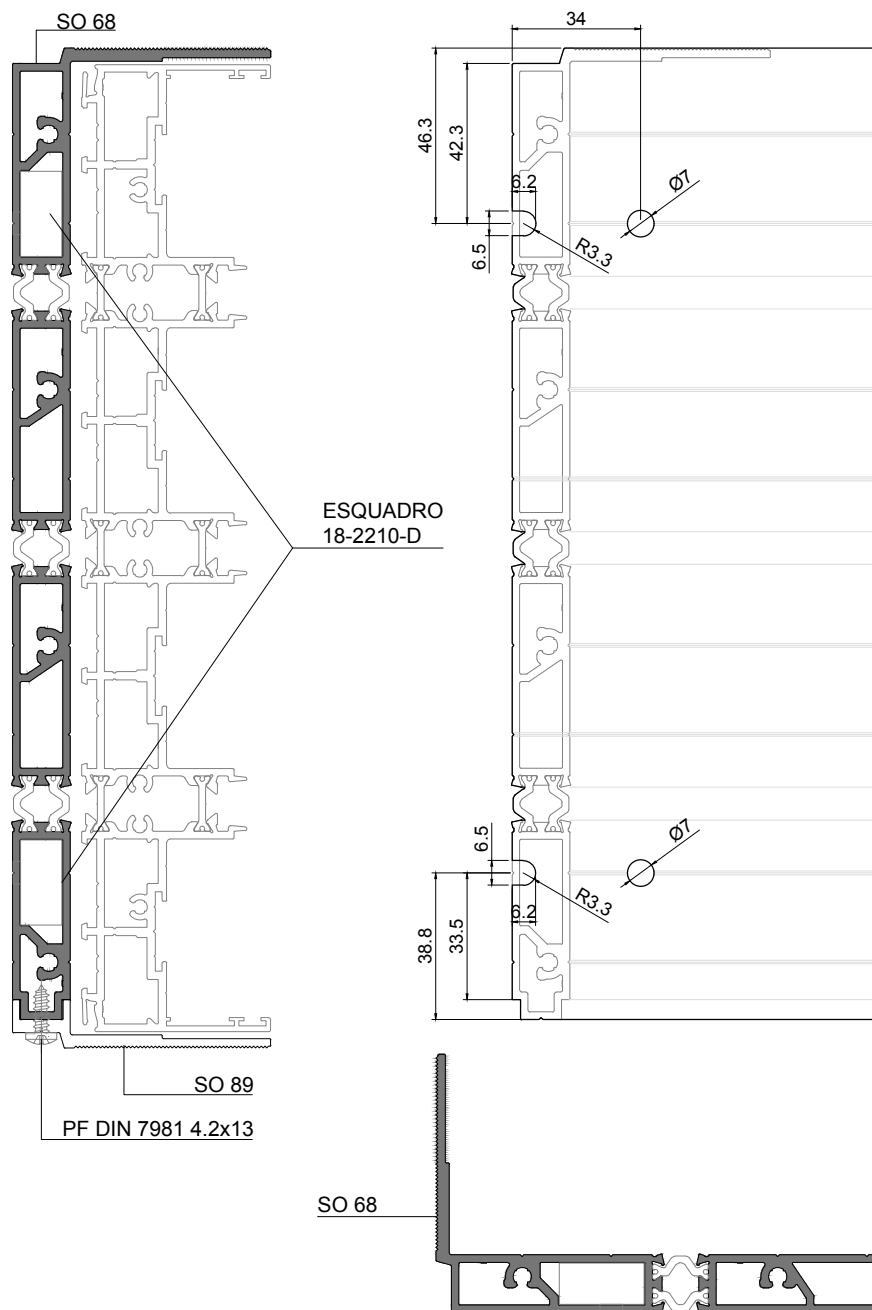

APLICAÇÃO DE PRÉ AROS - 4-RAIL

PRE-FRAMES APPLICATION - 4-RAIL | APPLICATION DES PRÉ-CADRES - 4-RAIL

LIGAÇÃO A 45° COM ESQUADRO

45° CONNECTION WITH CORNER CLEATS | LIAISON À 45° AVEC EQUÉRRES

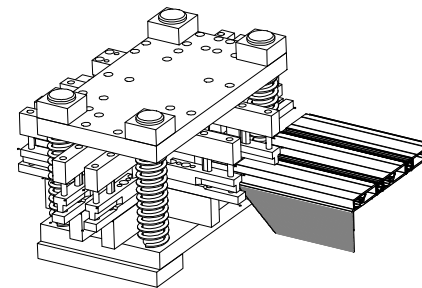
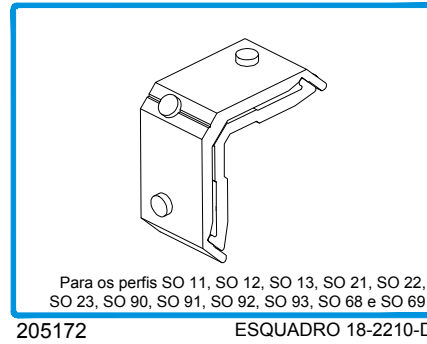
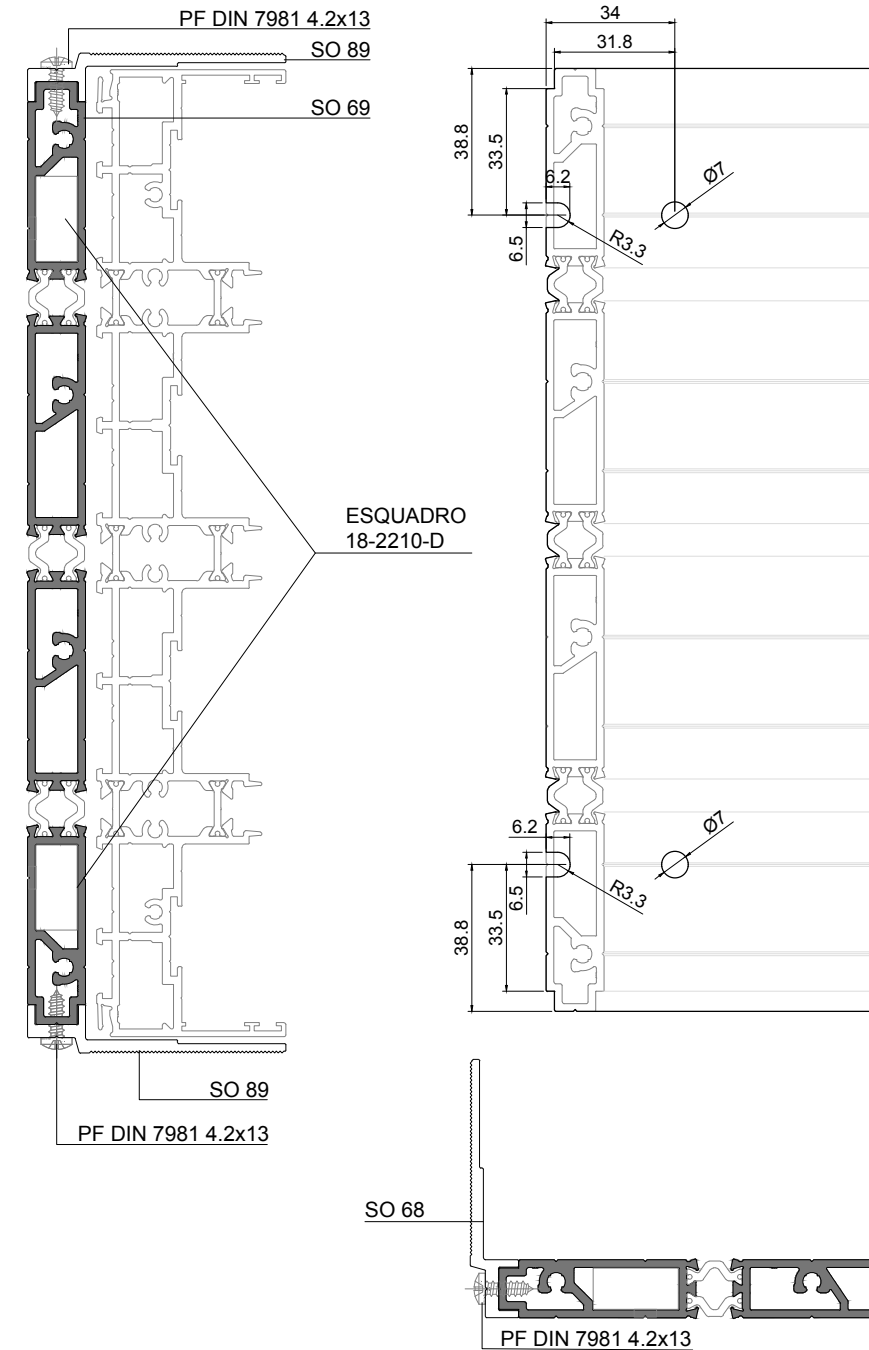

CORTANTE ESQUADROS OS Nº2
N. 2 OS CORNER CLEATS PUNCHING TOOL
POINÇON ÉQUERRES OS N.2

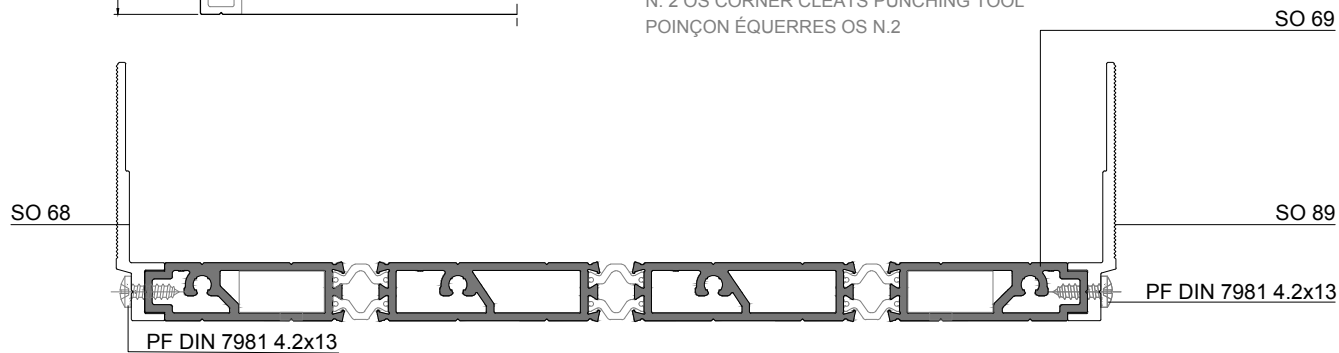
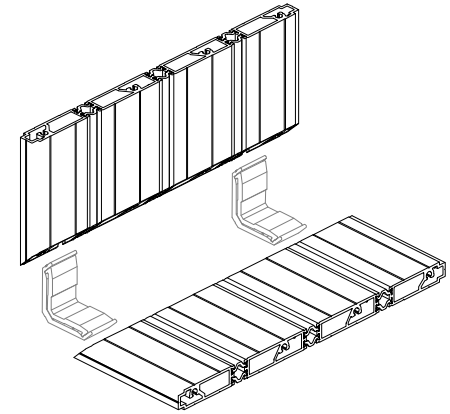

APLICAÇÃO DE PRÉ AROS - 4-RAIL

PRE-FRAMES APPLICATION - 4-RAIL | APPLICATION DES PRÉ-CADRES - 4-RAIL

LIGAÇÃO A 45° COM PARAFUSOS

45° CONNECTION WITH SCREWS | LIAISON À 45° AVEC VIS

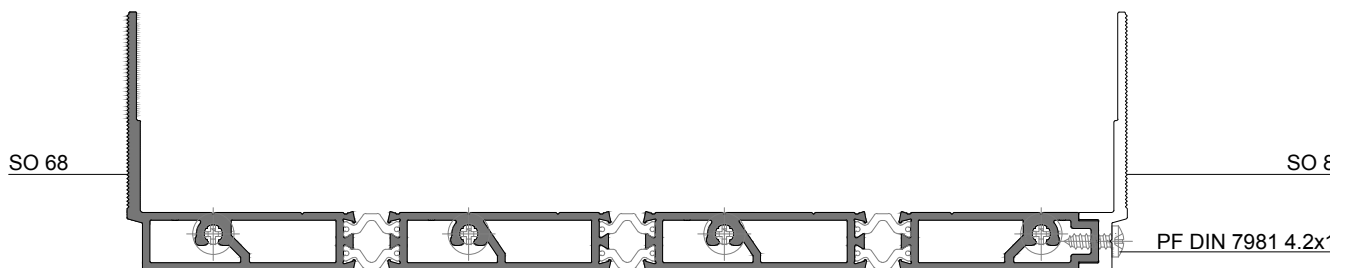
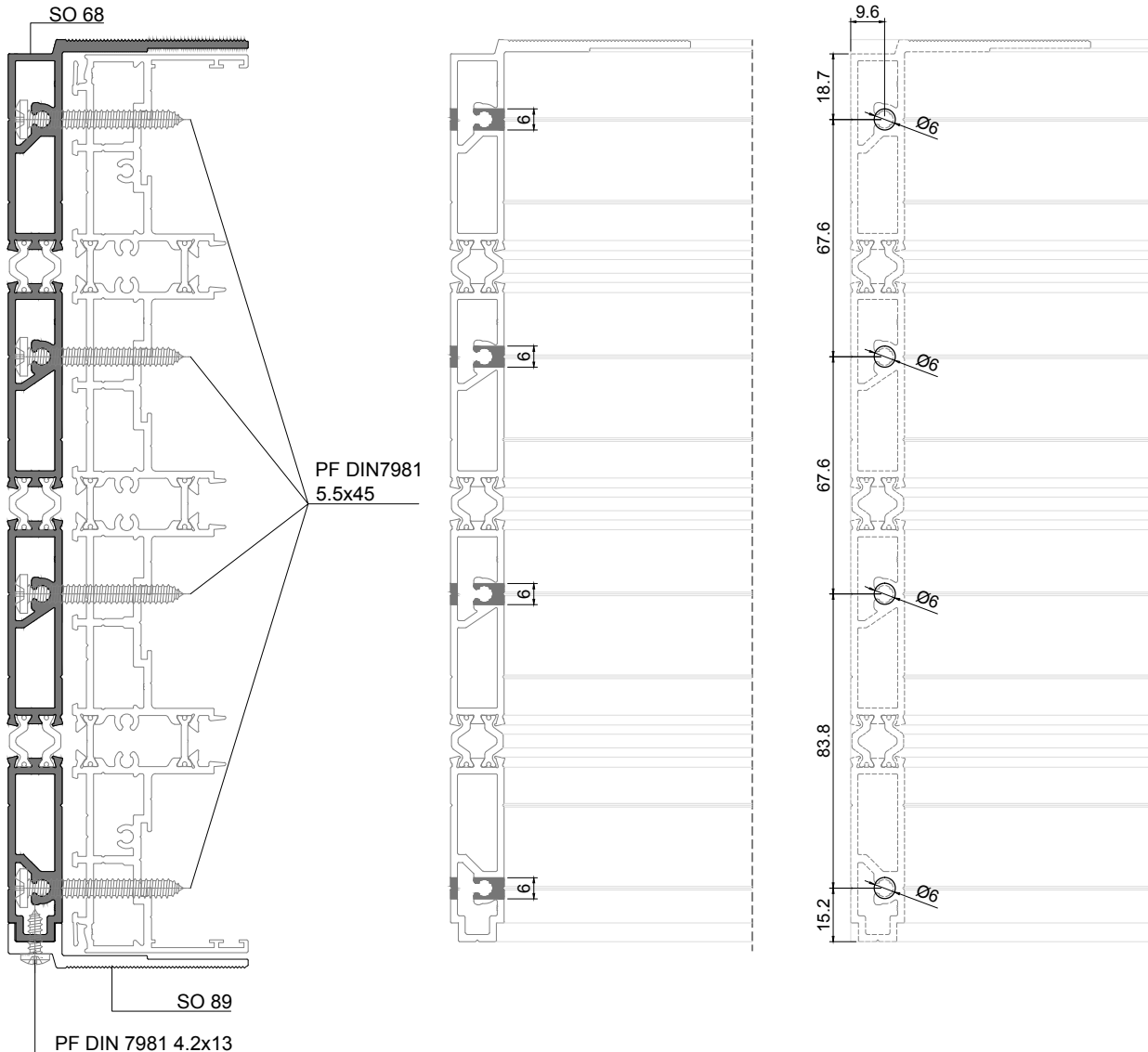
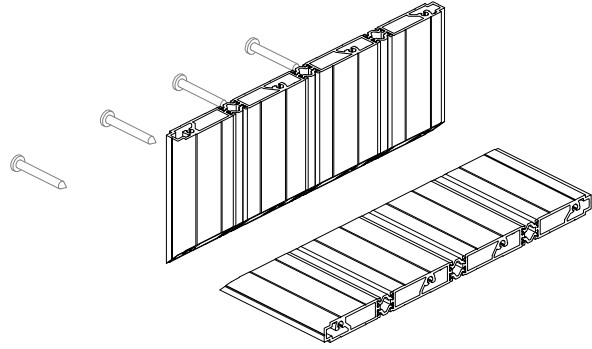

APLICAÇÃO DE PRÉ AROS - 4-RAIL

PRE-FRAMES APPLICATION - 4-RAIL | APPLICATION DES PRÉ-CADRES - 4-RAIL

APLICAÇÃO PRÉ-ARO EMALHETADO NAS LATERAIS + PERFIL DE SOLEIRA

CUTED PRE-FRAMES ON LATERALS + SILL PROFILE APPLICATION | PRÉ-CADRES COUPÉS DANS LES LATÉRAUX + PROFILÉ DE SEUIL

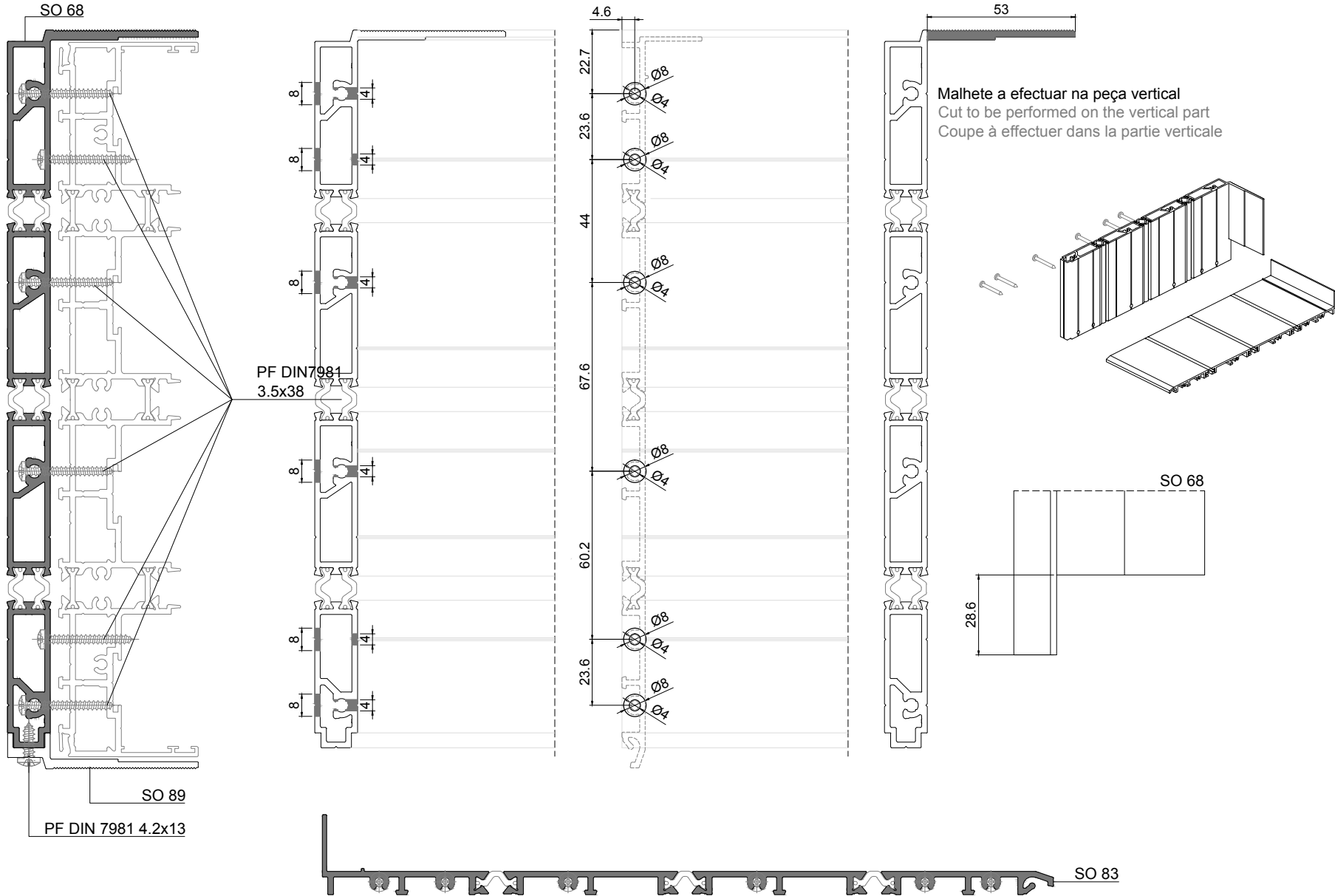

APLICAÇÃO DE PRÉ AROS - 4-RAIL

PRE-FRAMES APPLICATION - 4-RAIL | APPLICATION DES PRÉ-CADRES - 4-RAIL

LIGAÇÃO A 90° SEM MALHETE + PERFIL DE SOLEIRA

90° CONNECTION WITHOUT CUTS + SILL PROFILE APPLICATION | LIAISON À 90° SANS CUPS + PROFILÉ DE SEUIL

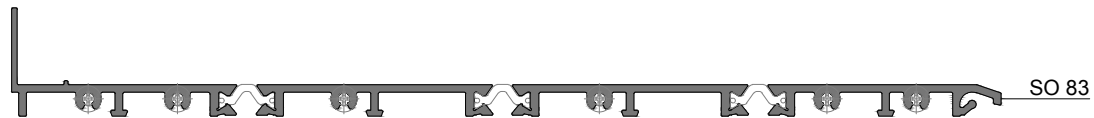
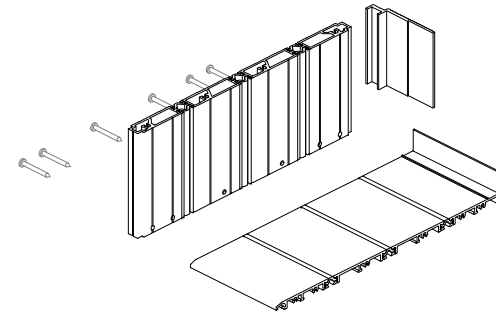
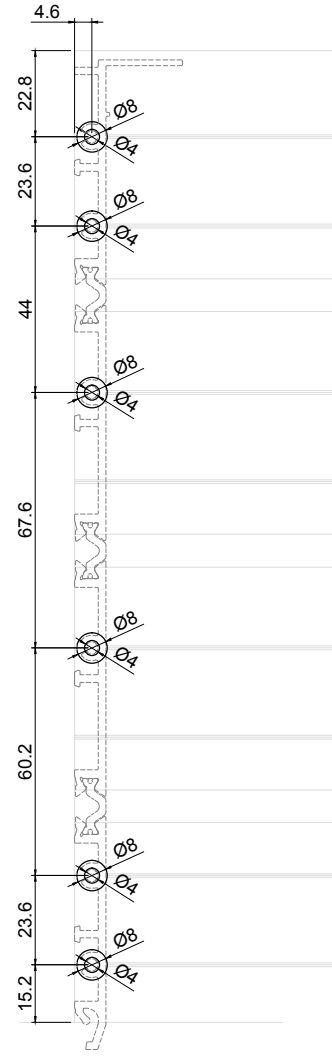
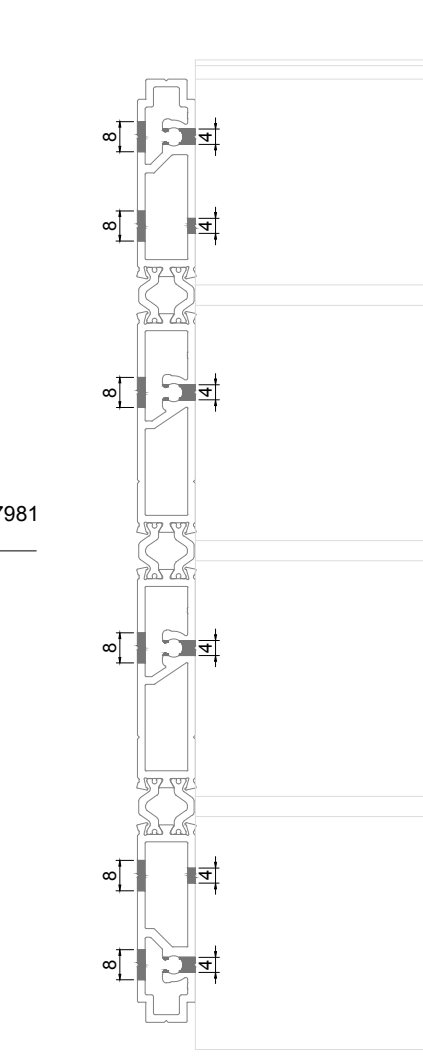
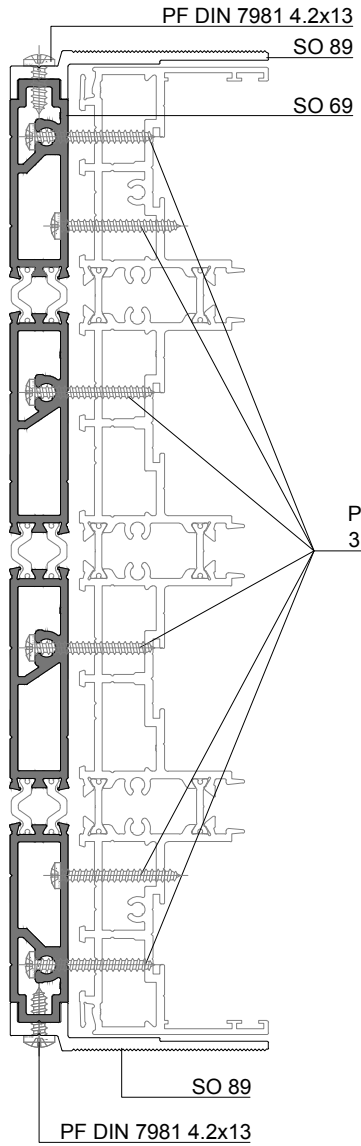



IX

SOLEIRAS E CALEIRAS
SILLS AND DRAINAGE CHANNELS | SEUILS ET GOUTTIÈRES DE VIDANGE

RELAÇÃO DE PERFIS SOLEIRA
SILLS PROFILES LIST | LISTE DES PROFILÉS DE SEUILS

SO 80
(soleira 1-rail para caleira)
(1-rail sill for drainage gutter | seuil 1-rail pour gouttière de sol)



SO 82
(soleira 2-rail para caleira)
(2-rail sill for drainage gutter | seuil 2-rail pour gouttière de sol)



SO 84
(soleira 3-rail para caleira)
(3-rail sill for drainage gutter | seuil 3-rail pour gouttière de sol)

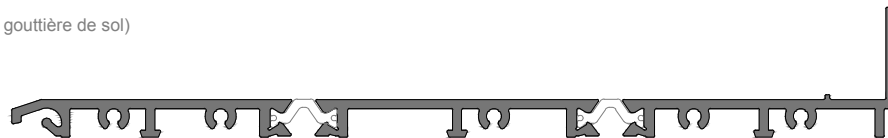

SO 83
(soleira 4-rail para caleira)
(4-rail sill for drainage gutter | seuil 4-rail pour gouttière de sol)

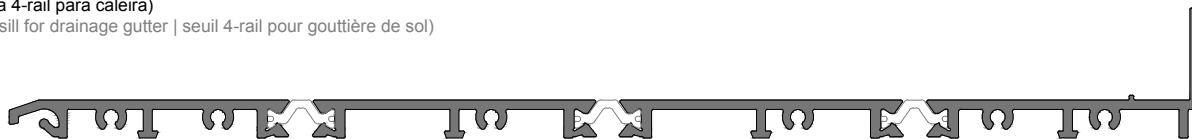

VO 22
(Soleira alta 2-rail para caleira)
(2-rail high Sill for drainage gutter | Seuil haut 2-rail pour gouttière de sol)

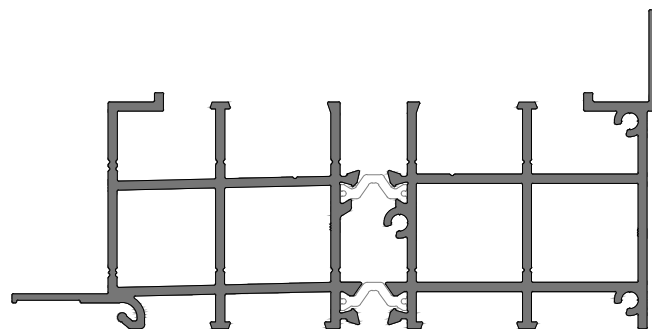

VO 23
(Soleira alta 3-rail para caleira)
(3-rail high Sill for drainage gutter | Seuil haut 3-rail pour gouttière de sol)

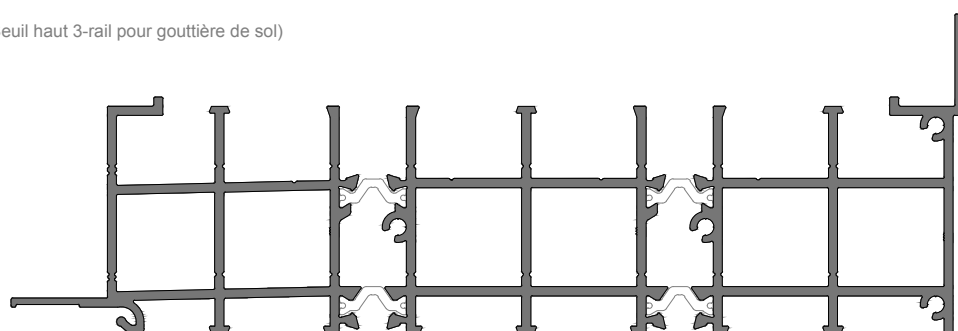

RELAÇÃO DE PERFIS CALEIRA

DRAINAGE CHANNEL PROFILES LIST | LISTE DES PROFILÉS POUR GOUTTIÈRE DE VIDANGE

SO 26 | SO 58

(tampas baixas para caleira)

(short drainage channel grids | grilles bas pour gouttière de vidange)



SO 27 | SO 59

(tampas altas para caleira)

(tall drainage channel grids | grilles hautes pour gouttière de vidange)



VO 11

(perfil fixação da tampa de caleira)

(drainage channel grid profile | profilé pour fixation de grille pour gouttière de vidange)

Peças com 400mm, aplicadas aproximadamente a cada 800mm.

Pieces 400mm long, applied approximately every 800mm.

Pièces de 400 mm, appliquées à environ tous les 800 mm.

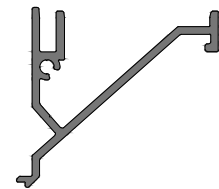

SO 25

(caleira)

(drainage channel | gouttière de vidange)

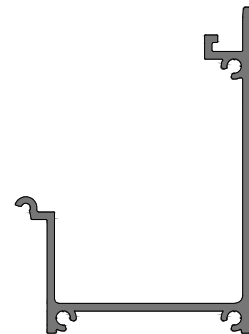

VO 25

(Caleira)

(Drainage channel | Gouttière de vidange)



APLICAÇÃO DE SOLEIRAS E CALEIRAS - LINHA OS-D⁺ TRADICIONAL
SILLS AND DRAINAGE CHANNEL APPLICATION - OS-D⁺ CLASSIC LINE
APPLICATION DES SEUILS ET DES GOUTIÈRES DE VIDANGE - LIGNE OS-D⁺ CLASSIQUE

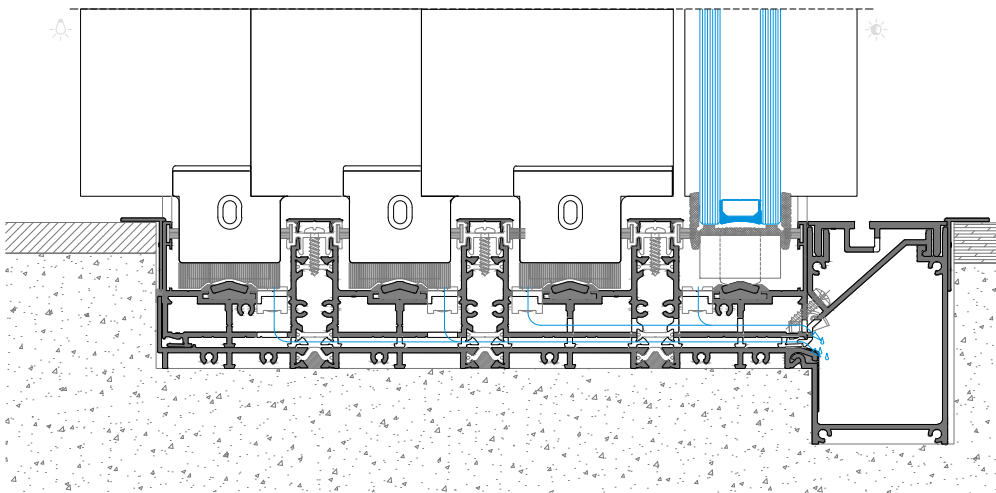
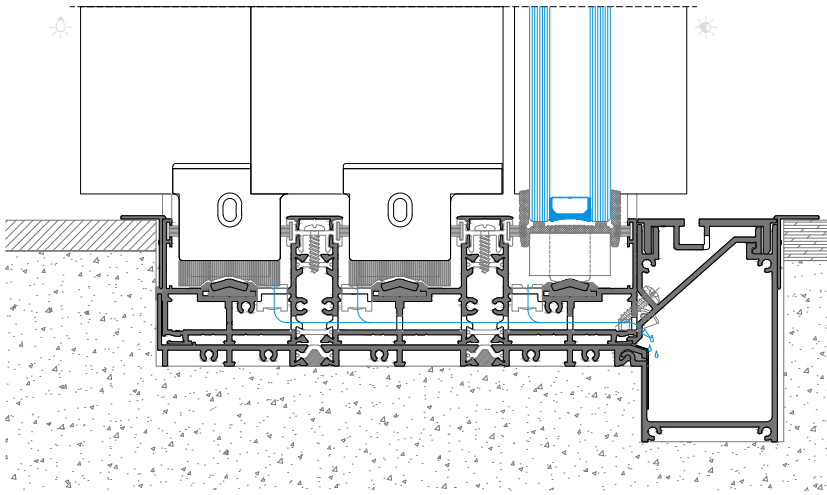
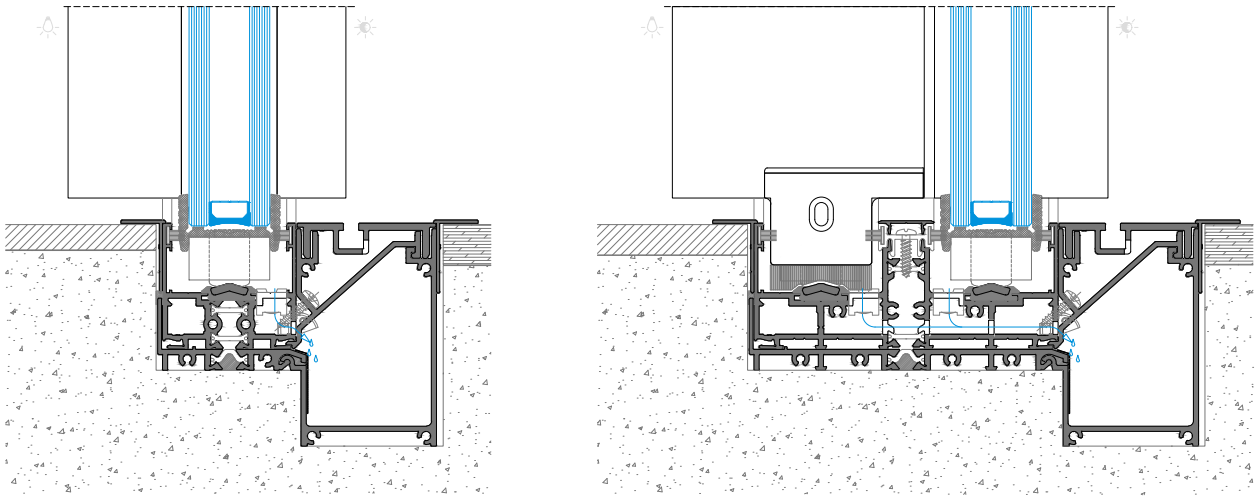

APLICAÇÃO DE SOLEIRAS E CALEIRAS - LINHA SOLEIRA OCULTA - Com Perfil OS 08

SILLS AND DRAINAGE CHANNEL APPLICATION - CONCEALED SILL LINE - With Profile OS 08

APPLICATION DES SEUILS ET DES GOUTTIÈRES DE VIDANGE - LIGNE SEUIL CACHÉ - Avec Profilé 08

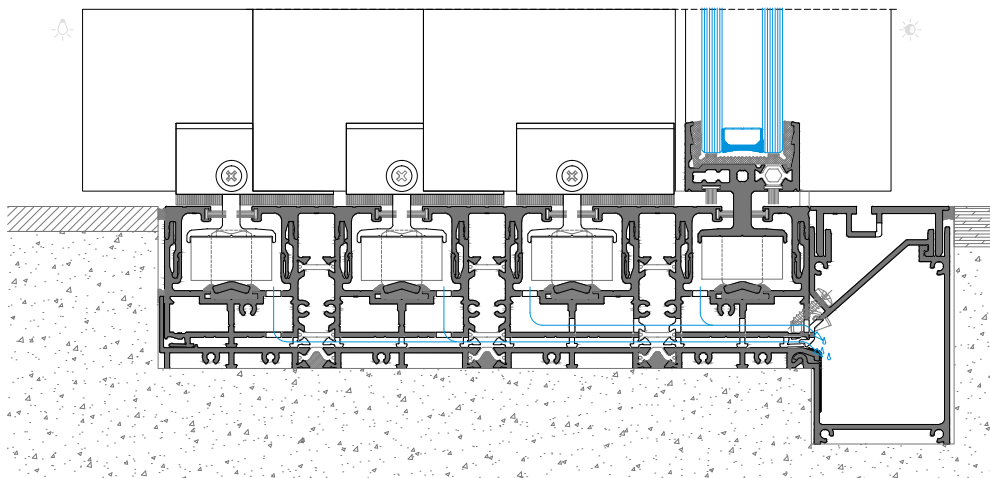
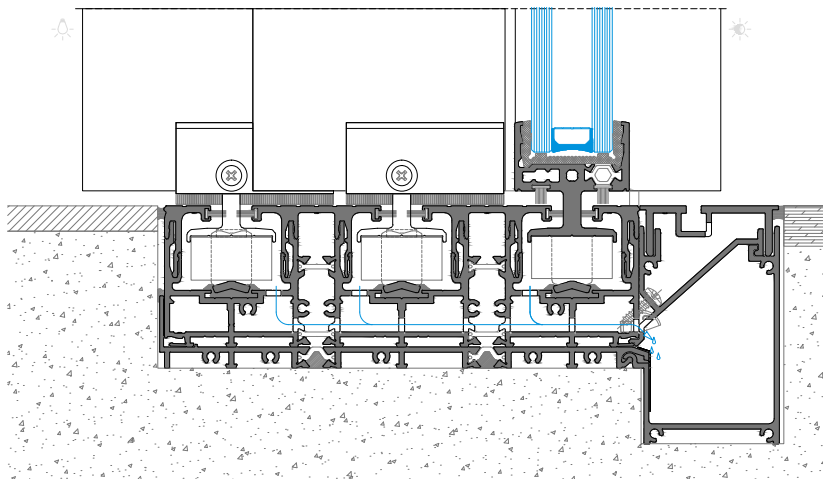
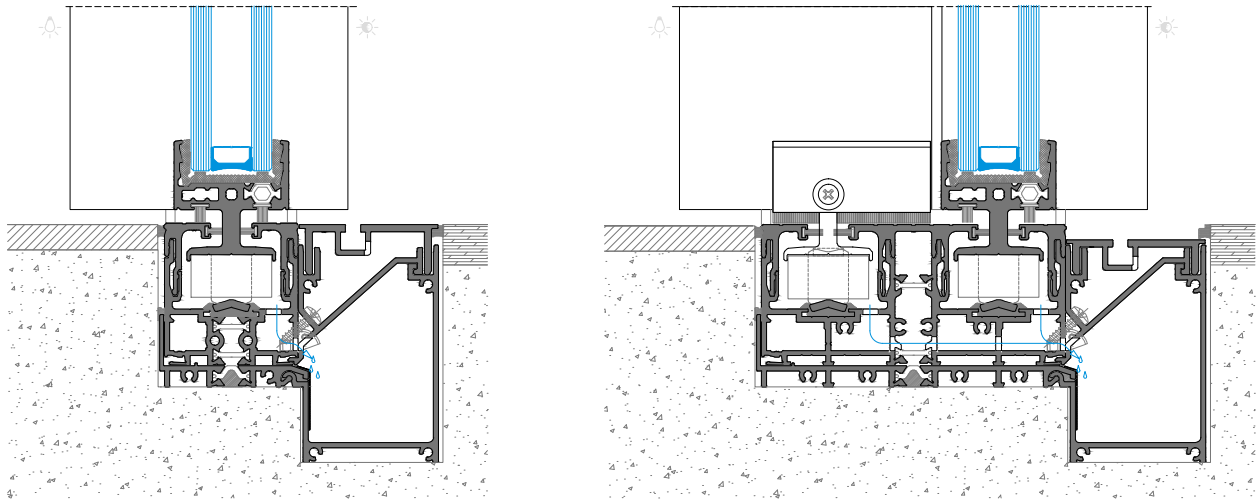

APLICAÇÃO DE SOLEIRAS E CALEIRAS - LINHA SOLEIRA OCULTA - Com Perfil OS 18

SILLS AND DRAINAGE CHANNEL APPLICATION - CONCEALED SILL LINE - With Profile OS 18

APPLICATION DES SEUILS ET DES GOUTTIÈRES DE VIDANGE - LIGNE SEUIL CACHÉ - Avec Profilé 18

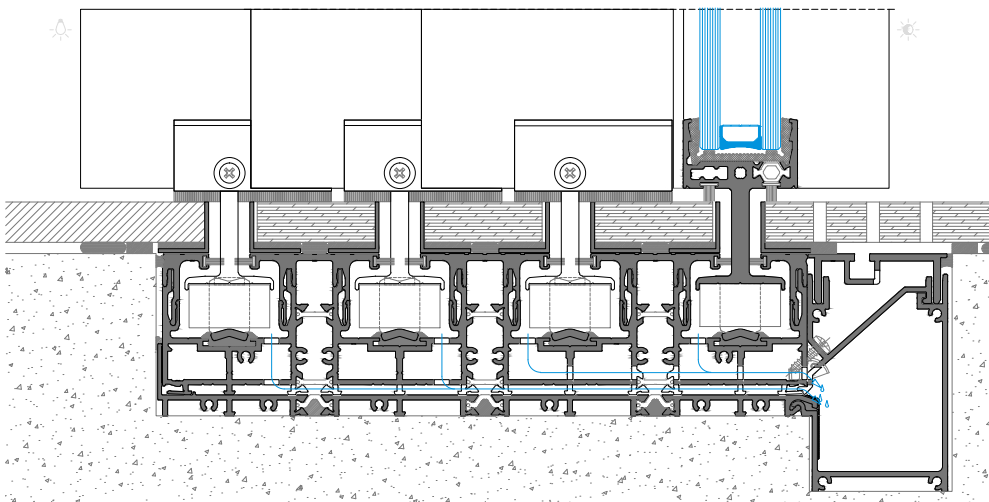
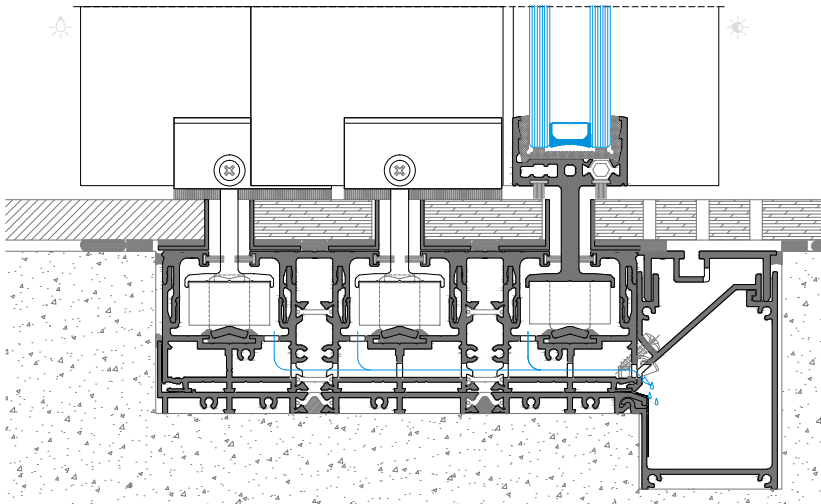
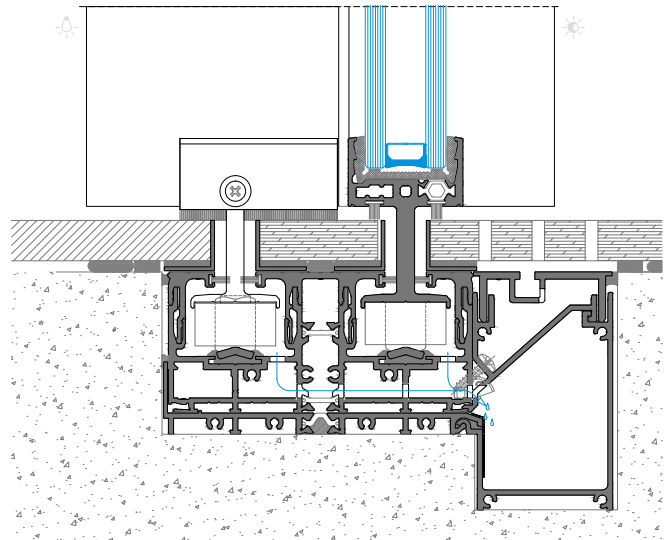
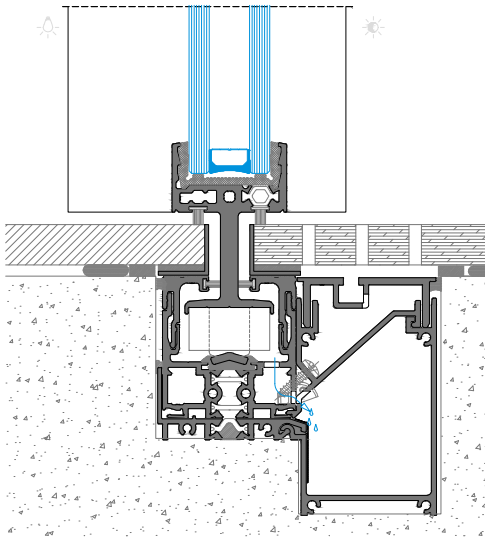

APLICAÇÃO DE SOLEIRAS E CALEIRAS ALTAS - LINHA OS-D⁺ TRADICIONAL COM PERFIL SO 58

HIGHT SILLS AND DRAINAGE CHANNEL APPLICATION - OS-D⁺ CLASSIC WITH SO 58 PROFILE

APPLICATION DES SEUILS ET DES GOUTTIÈRES DE VIDANGE HAUTES - LIGNE OS-D⁺ CLASSIQUE AVEC PROFILÉ SO 58

SOLUÇÃO 2-RAIL

2-RAIL SOLUTION | SOLUTION 2-RAIL

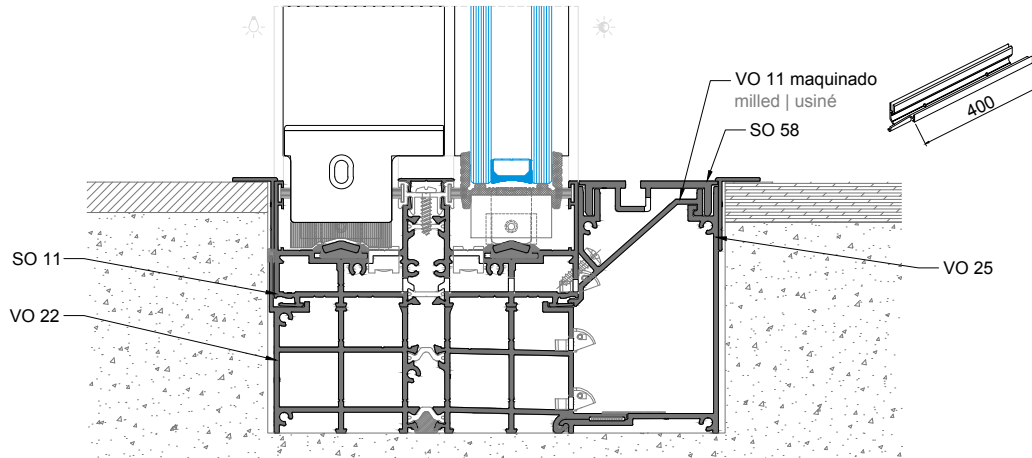

SOLUÇÃO 3-RAIL

3-RAIL SOLUTION | SOLUTION 3-RAIL

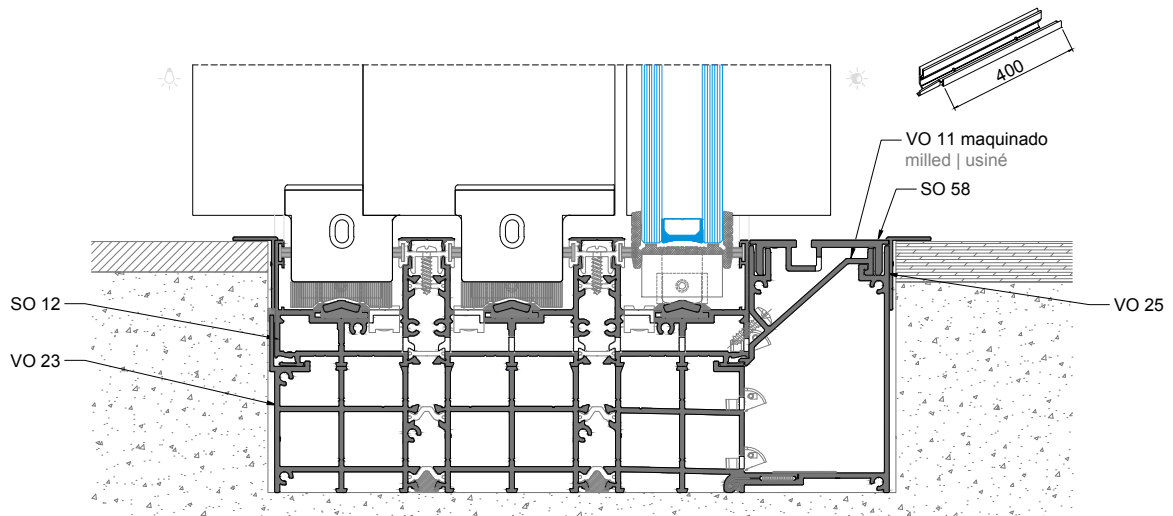

APLICAÇÃO DE SOLEIRAS E CALEIRAS - LINHA SOLEIRA OCULTA - Com Perfil OS 08
SILLS AND DRAINAGE CHANNEL APPLICATION - CONCEALED SILL LINE - With Profile OS 08
APPLICATION DES SEUILS ET DES GOUTTIÈRES DE VIDANGE - LIGNE SEUIL CACHÉ - Avec Profilé 08

SOLUÇÃO 2-RAIL
2-RAIL SOLUTION | SOLUTION 2-RAIL

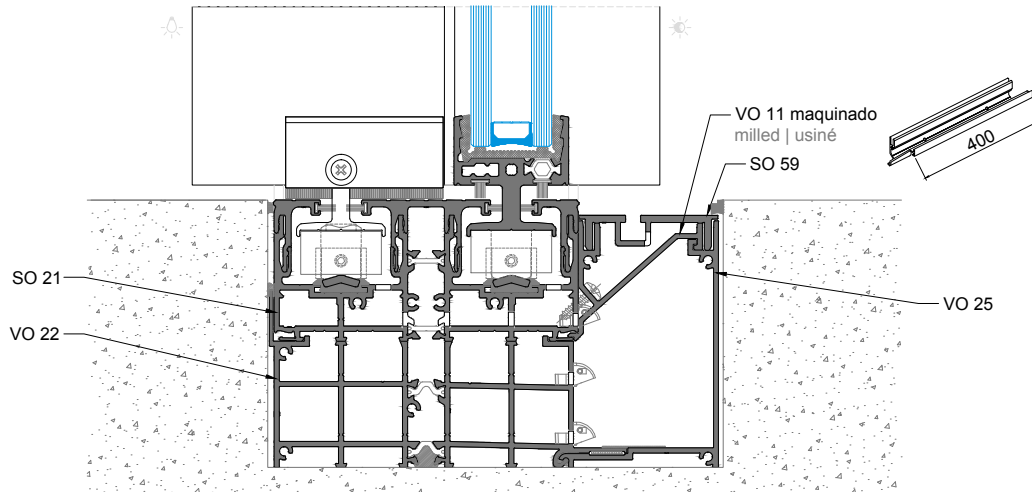

SOLUÇÃO 3-RAIL
3-RAIL SOLUTION | SOLUTION 3-RAIL

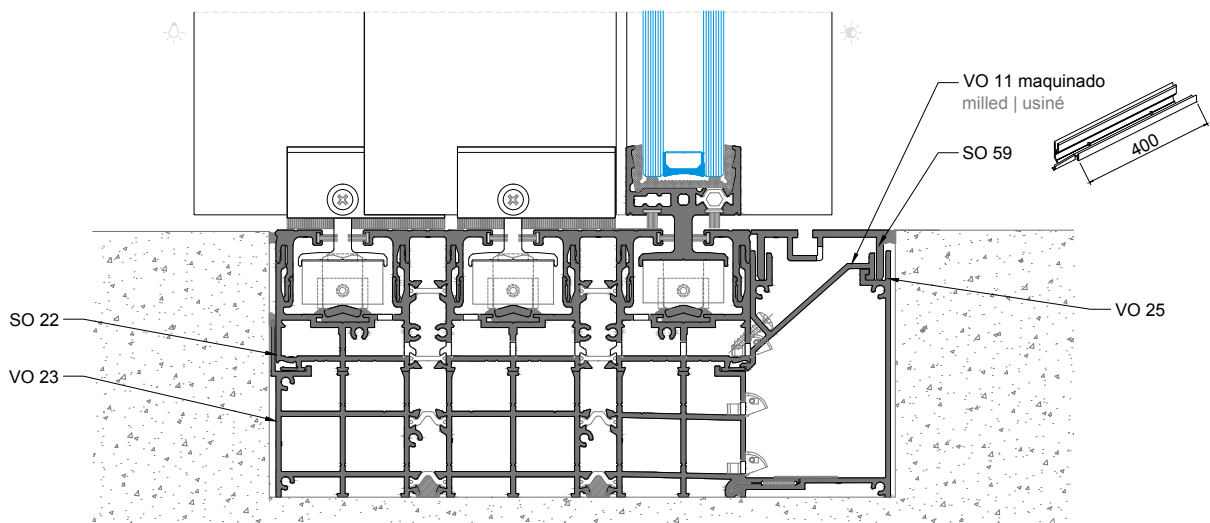

APLICAÇÃO DE SOLEIRAS E CALEIRAS - LINHA SOLEIRA OCULTA - Com Perfil OS 18
SILLS AND DRAINAGE CHANNEL APPLICATION - CONCEALED SILL LINE - With Profile OS 18
APPLICATION DES SEUILS ET DES GOUTTIÈRES DE VIDANGE - LIGNE SEUIL CACHÉ - Avec Profilé 18

SOLUÇÃO 2-RAIL
2-RAIL SOLUTION | SOLUTION 2-RAIL

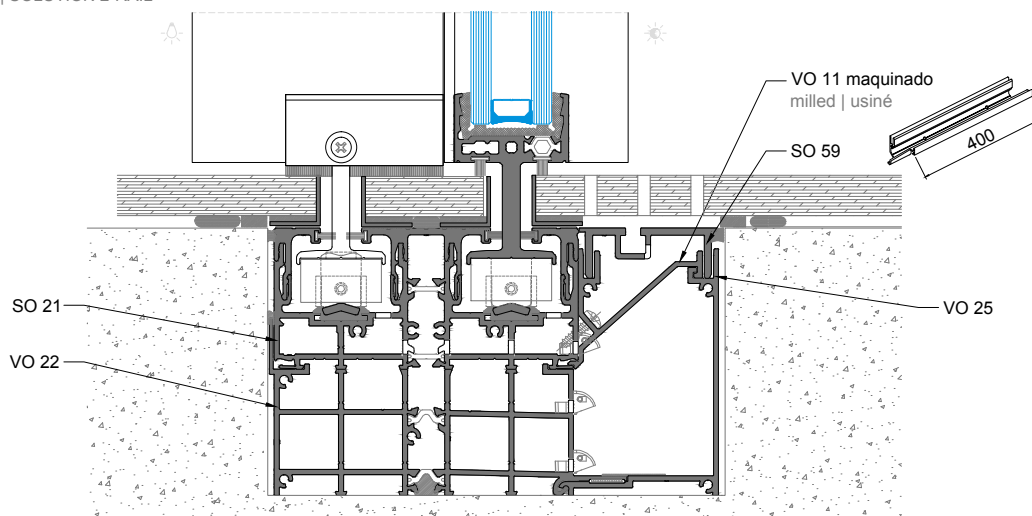

SOLUÇÃO 3-RAIL
3-RAIL SOLUTION | SOLUTION 3-RAIL

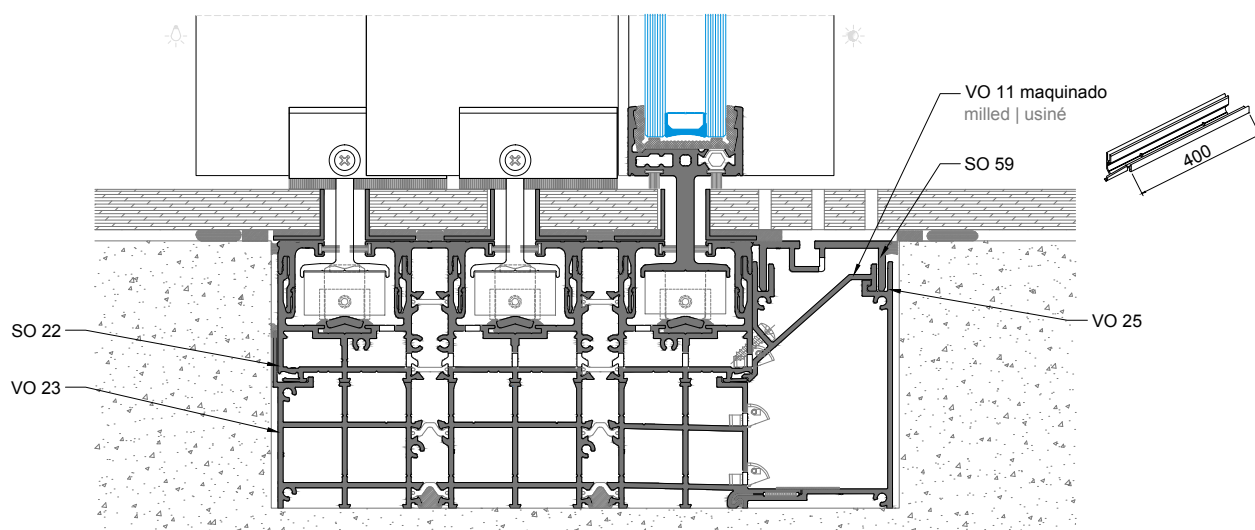

MAQUINAÇÃO DOS PERFIS SO 26 e SO 27

OS 26 and OS 27 PROFILES MACHINING

USINAGES DES PROFILÉS OS 26 et OS 27

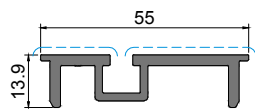

SO 26

(tampa baixa para caleira)
(short drainage channel grid | grille bas pour gouttière de vidange)

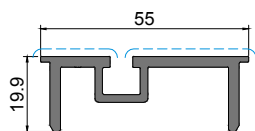

SO 27

(tampa alta para caleira)
(tall drainage channel grid | grille haute pour gouttière de vidange)

Acabamento | Finish | Finitions:
Anodizado | Anodised | Anodisé



Acabamento | Finish | Finitions:
Anodizado | Anodised | Anodisé



SO 58 E SO 59

Perfis previamente maquinados

OS 58 and OS 59 - Pre-machined profiles

OS 58 and OS 59 - Profilés pré-usinés

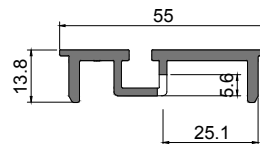

SO 58

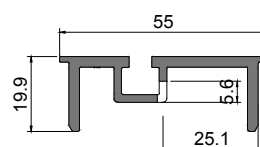

SO 59

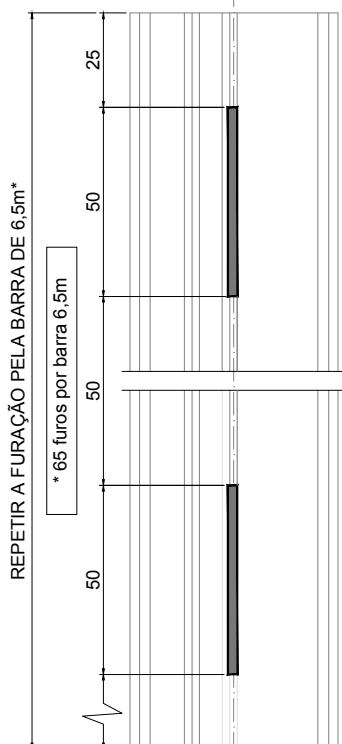
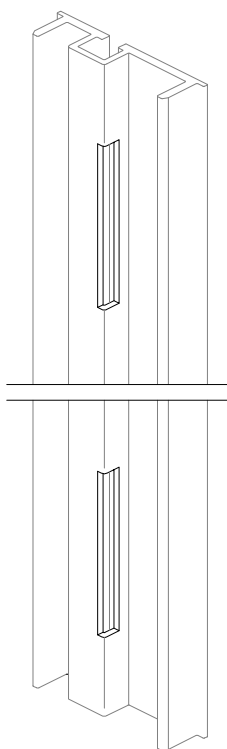

MAQUINAÇÃO DO PERFIL VO 11
VO 11 PROFILE MACHINING
USINAGE DE PROFILÉ VO 11

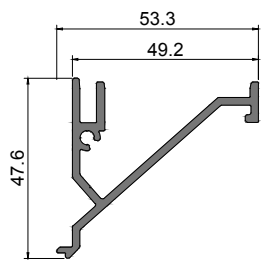

VO 11

(perfil fixação da tampa de caleira)
(drainage channel grid profile | profilé
pour fixation de grille pour gouttière de
vidange)

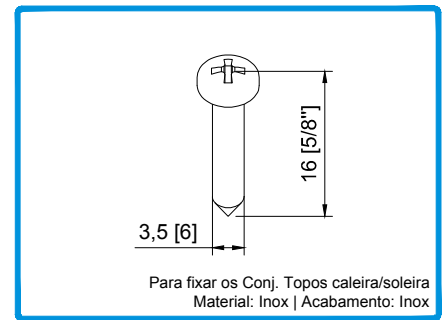
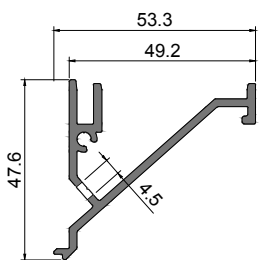

Para fixar os Conj. Topos caleira/soleira
Material: Inox | Acabamento: Inox

290729

PARAF PKI PH 5/8x6 CQ

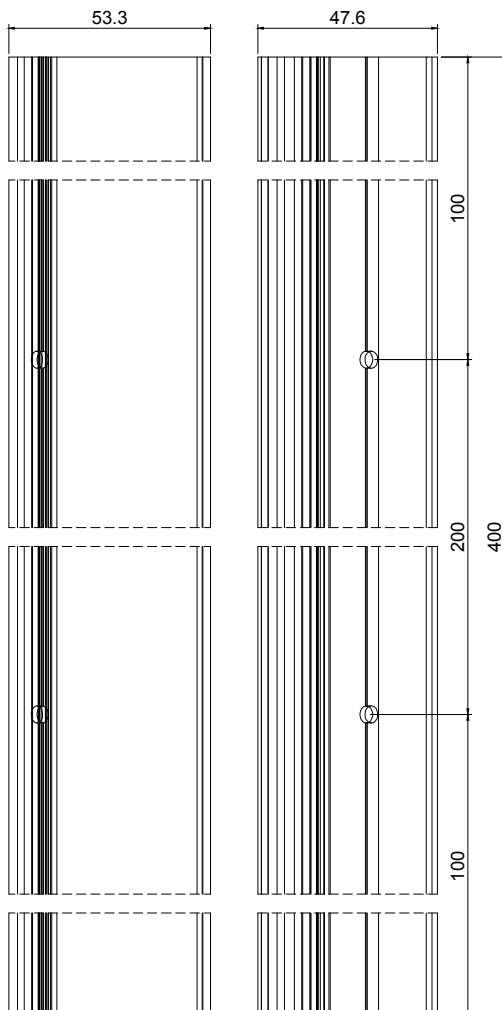
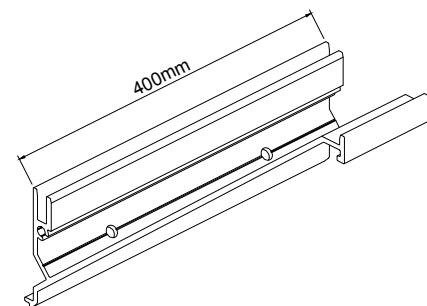

Peça de fixação da caleira fabricada a através do perfil VO 11.
Peças com 400mm, aplicadas aproximadamente a cada 800mm.

Channel grid fixing piece manufactured through VO 11 profile.
Pieces 400mm long, applied approximately every 800mm.

Pièce de fixation de grille fabriquée à partir du profilé VO 11.
Pièces de 400 mm, appliquées à environ tous les 800 mm.

MONTAGEM DA CALEIRA NA SOLEIRA

ASSEMBLY OF THE DRAINAGE CHANNEL IN THE DRAINAGE GUTTER

ASSEMBLAGE DE LA GOUÏTIÈRE DE VIDANGE SUR LE GOUÏTIÈRE DE SOL

OPERAÇÕES DE SELAGEM A EFECTUAR EM TODAS AS SOLEIRAS DAS SOLUÇÕES OS-D⁺

SEALING OPERATIONS IN ALL SOLUTIONS OS-D⁺

OPERATIONS D'ÉTANCHÉITÉ À RÉALISER SUR TOUS LES SOLUTIONS OS-D⁺

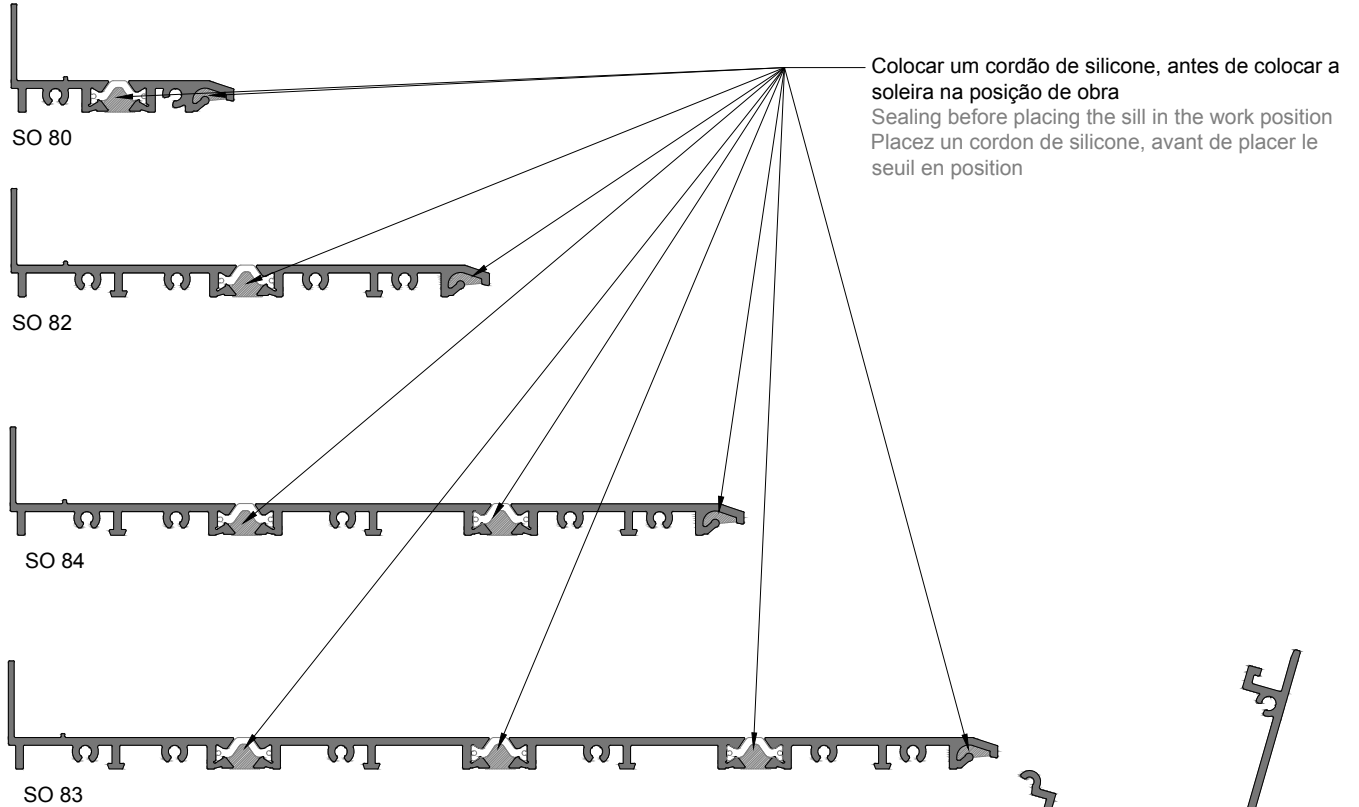

Colocar um cordão de silicone, antes de colocar a soleira na posição de obra
Sealing before placing the sill in the work position
Placez un cordon de silicone, avant de placer le seuil en position

Antes de aplicar o caixilho sobre a soleira, fazer uma selagem com cordão de silicone e fita entre a soleira e a caleira
Before applying the frame over the sill, seal it with a silicone and sealing membrane between the sill and the drainage channel
Avant placer le cadre sur le seuil, scellez avec un cordon de silicone et en membrane d'étanchéité entre le seuil et la gouttière

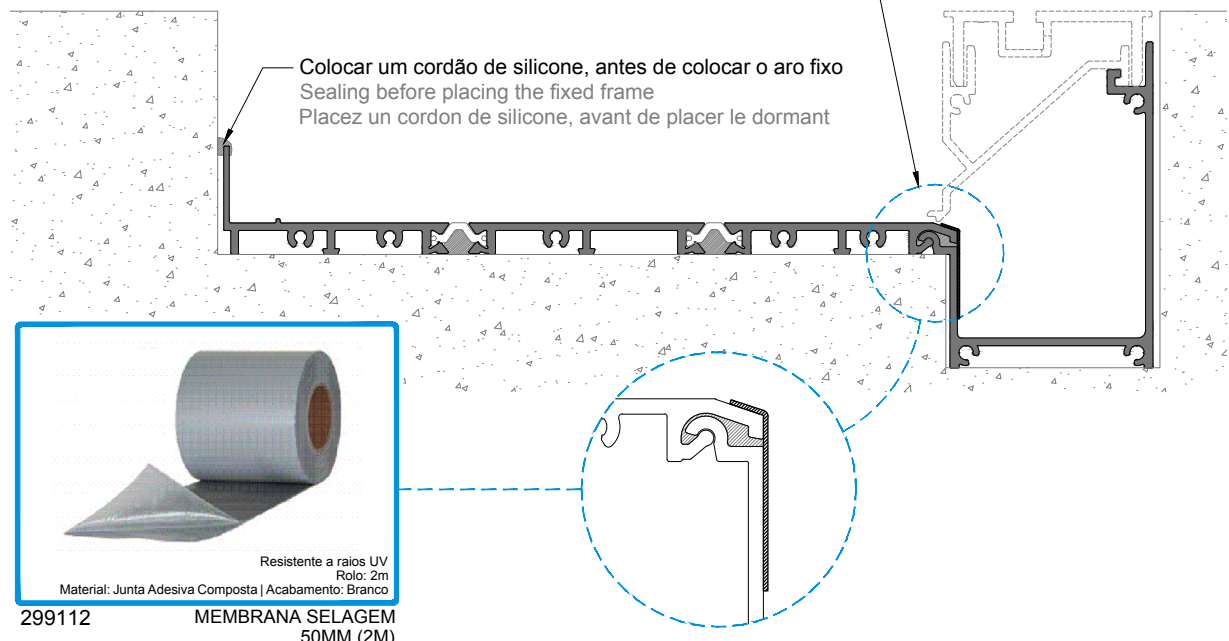

MONTAGEM DA CALEIRA ALTA NA SOLEIRA ALTA

ASSEMBLY OF THE HIGH DRAINAGE CHANNEL IN THE HIGH DRAINAGE GUTTER

MONTAGE DE LA GOUTTIÈRE DE VIDANGE HAUTE SUR LE GOUTTIÈRE DE SOL HAUTE

OPERAÇÕES DE SELAGEM A EFECTUAR EM TODAS AS SOLEIRAS ALTAS DAS SOLUÇÕES OS-D⁺

SEALING OPERATIONS TO BE CARRIED OUT ON ALL HIGH SILL SOLUTIONS OS-D⁺

OPERATIONS D'ÉTANCHÉITÉ À RÉALISER SUR TOUS LES SEUIL HAUT DES SOLUTIONS OS-D⁺

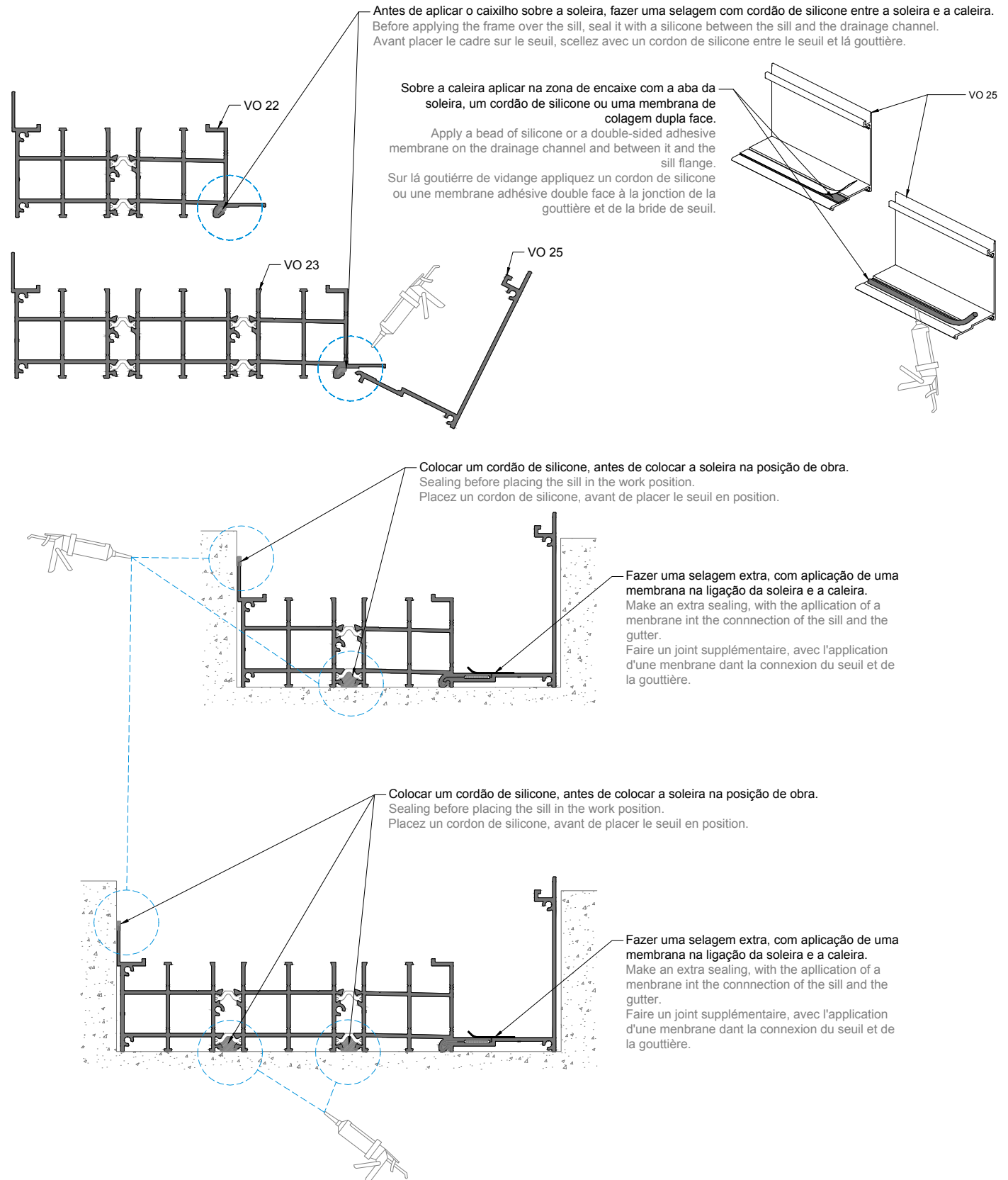

TOPOS PARA CALEIRA/SOLEIRA
DRAINAGE CHANNEL/DRAINAGE GUTTER END-CAPS
EMBOUTS POUR GOUTIÈRE DE VIDANGE/GOUTIÈRE DE SOL

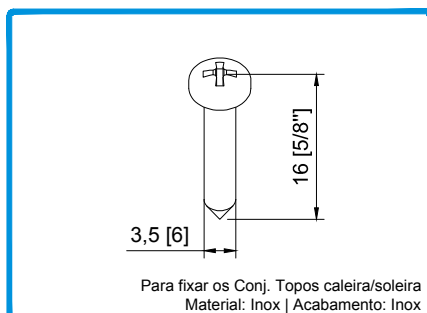

290729 PARAF PKI PH 5/8x6 CQ

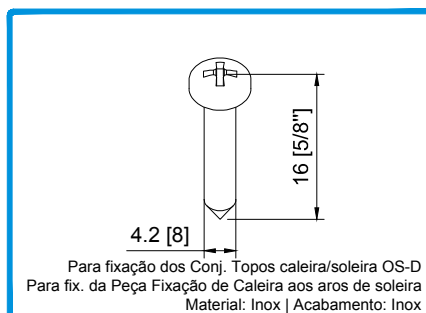

290088 PARAF. DIN7981 PH 4,2x16 INOX A2

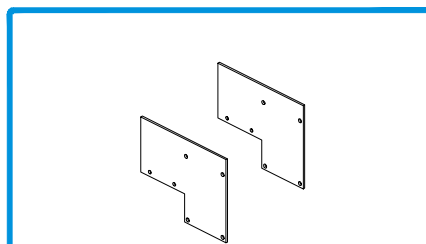
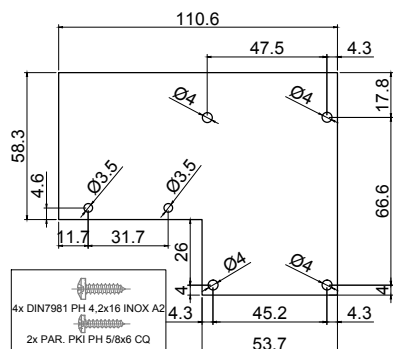

212245 CONJUNTO TOPOS CALEIRA/SOLEIRA OS-D 1-RAIL
Material: Alumínio (2mm espessura)

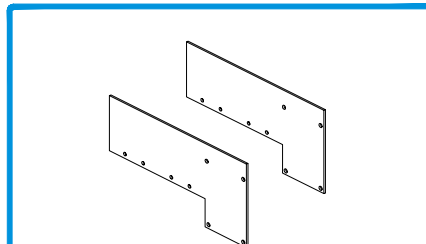
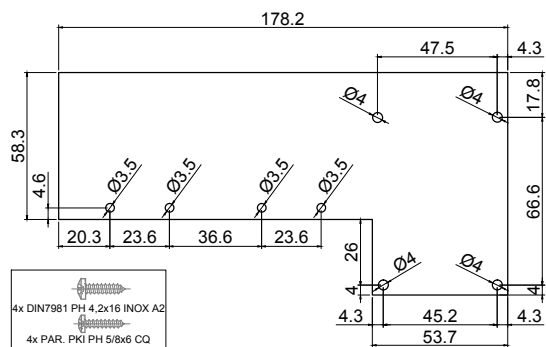

212246 CONJUNTO TOPOS CALEIRA/SOLEIRA OS-D 2-RAIL
Material: Alumínio (2mm espessura)

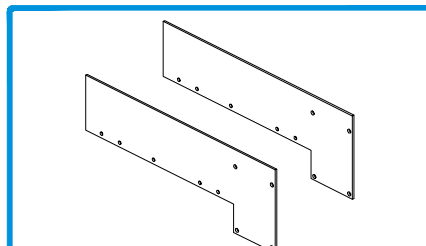
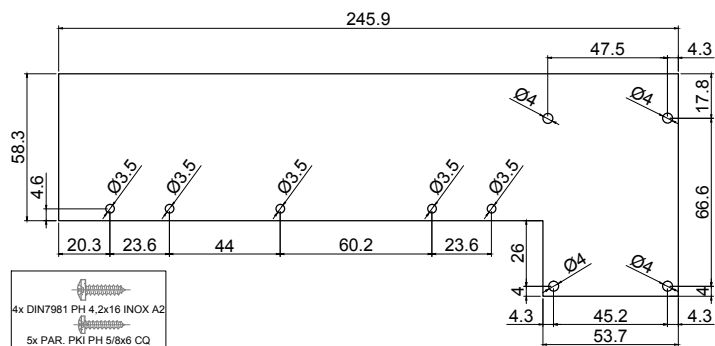

212247 CONJUNTO TOPOS CALEIRA/SOLEIRA OS-D 3-RAIL
Material: Alumínio (2mm espessura)

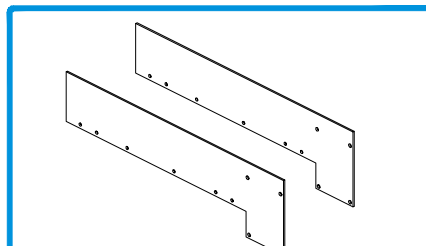
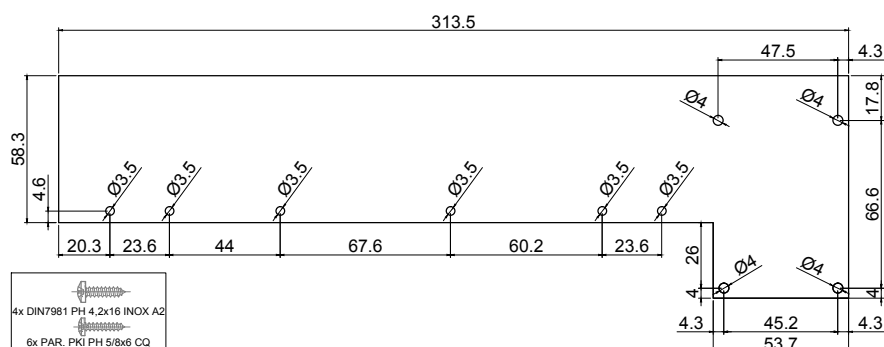

212251 CONJUNTO TOPOS CALEIRA/SOLEIRA OS-D 4-RAIL
Material: Alumínio (2mm espessura)

APLICAÇÃO DOS TOPOS PARA CALEIRA/SOLEIRA - LINHA TRADICIONAL
APPLICATION OF THE DRAINAGE CHANNEL/DRAINAGE GUTTER END-CAPS - CLASSIC LINE
APPLICATION D'EMBOUS POUR GOUTTIÈRE DE VIDANGE/GOUTTIÈRE DE SOL - LIGNE CLASSIQUE

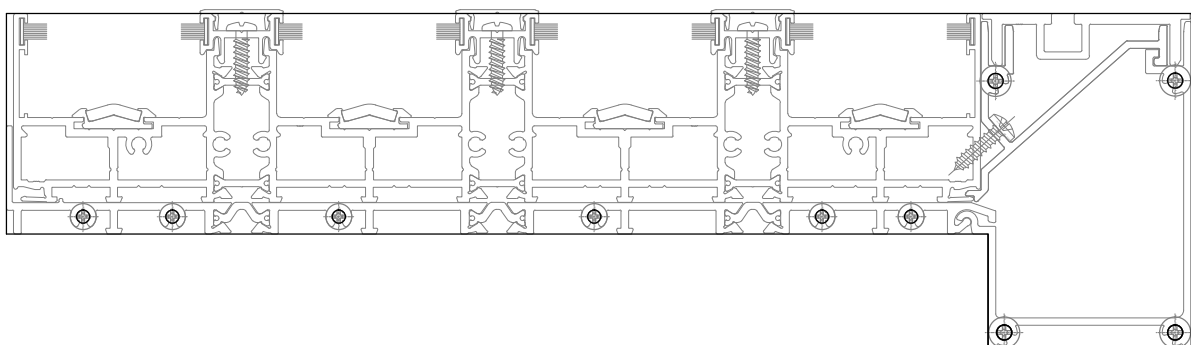
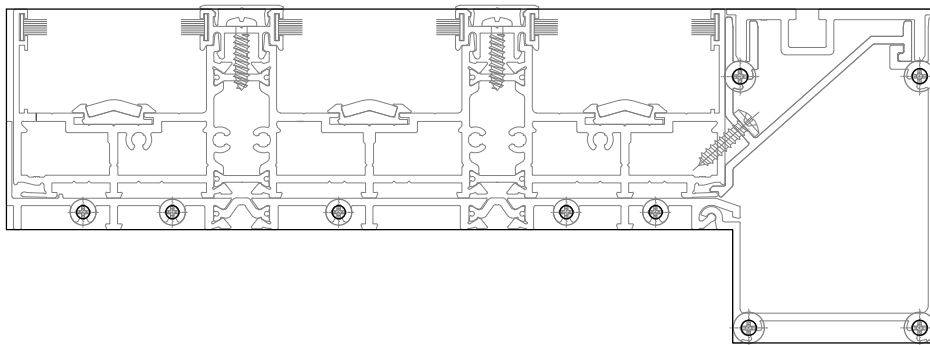
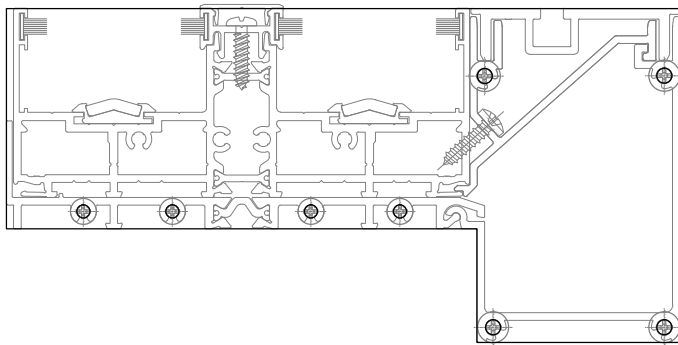
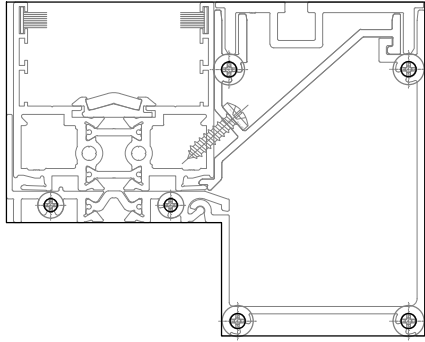

APLICAÇÃO DOS TOPOS PARA CALEIRA/SOLEIRA - LINHA SOLEIRA OCULTA
APPLICATION OF THE DRAINAGE CHANNEL/DRAINAGE GUTTER END-CAPS - CONCEALED SILL LINE
APPLICATION D'EMBOUTS POUR GOUTTIÈRE DE VIDANGE/GOUTTIÈRE DE SOL - LIGNE SEUIL CACHÉ

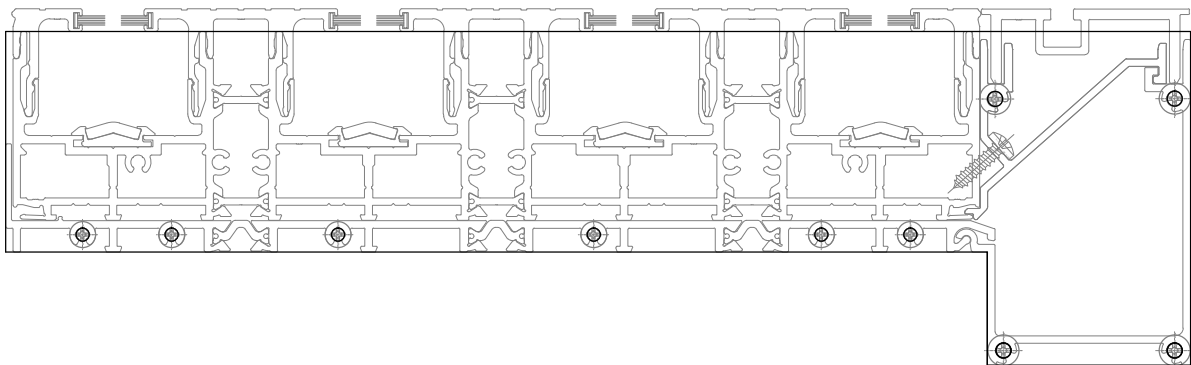
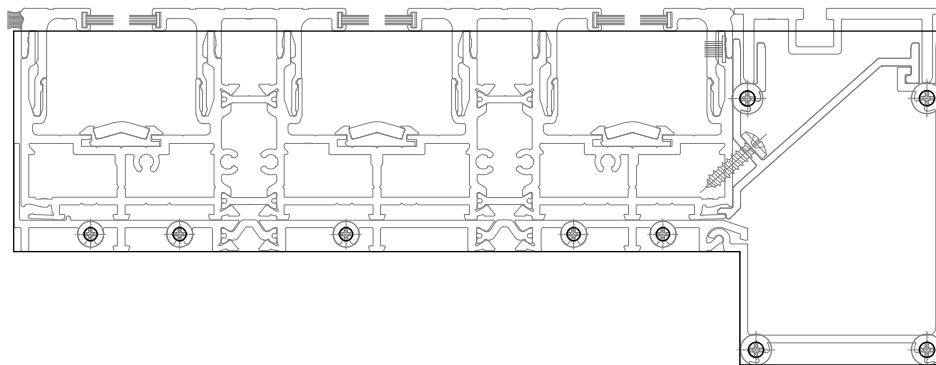
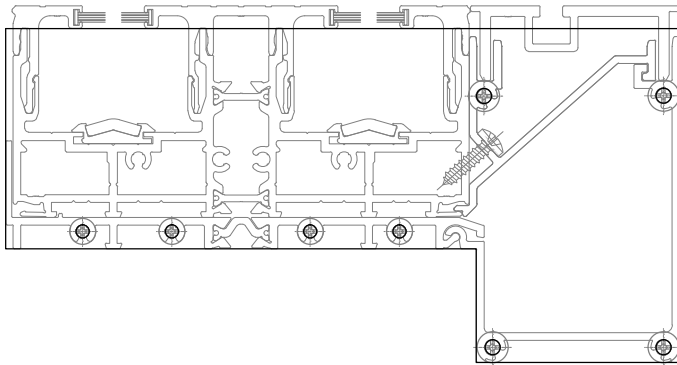
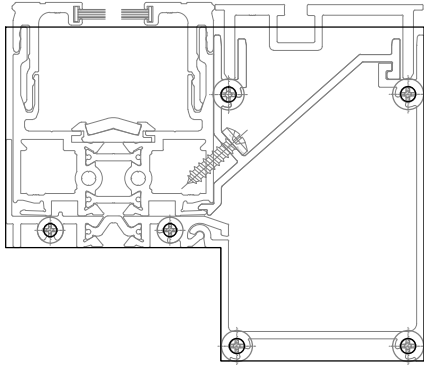

OPERAÇÕES DE SELAGEM A EFECTUAR EM SOLEIRAS

SEALING OPERATIONS TO BE EXECUTED ON SILLS

OPERATIONS D'ÉTANCHÉITÉ À RÉALISER SUR LES SEUILS

1. Selar as arestas com silicone antes de aplicar os topos

Seal edges with silicone before applying end-caps
Sceller les bords avec silicone avant d'appliquer l'embouts

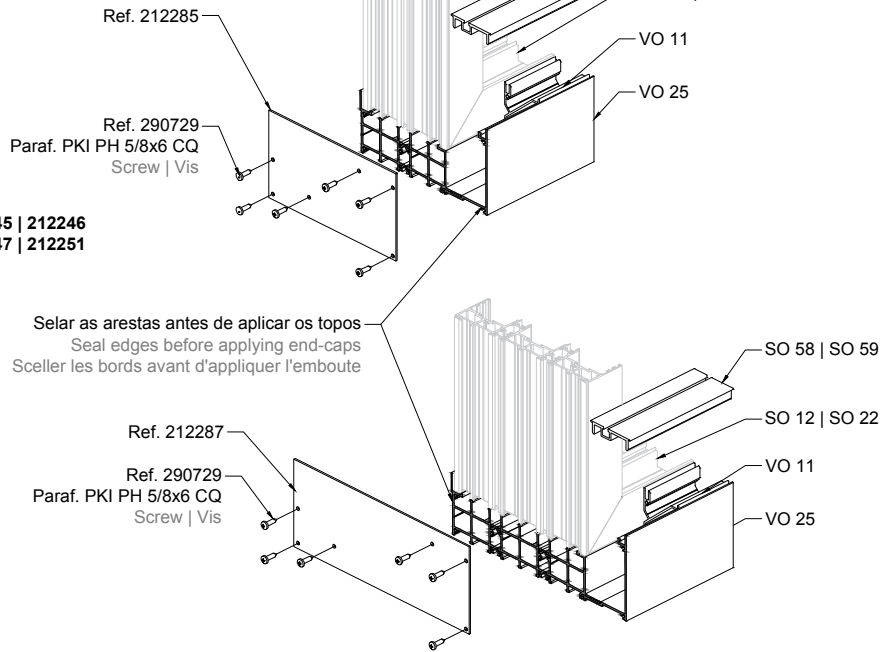
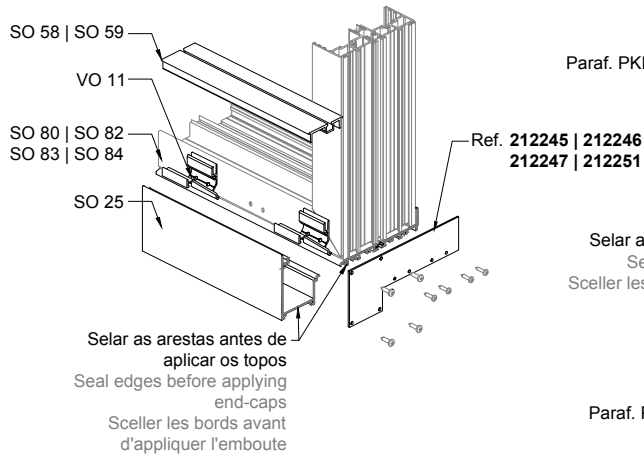

2. Aplicar a Membrana de selagem nas emendas da caleira: vãos com largura superior a 6,5m e vãos de canto

Apply Sealing membrane to the gutter seams: frames with width greater than 6.5m or in corners

Appliquer la Membrane d'étanchéité sur les joints de gouttière: cadres avec largeur supérieure à 6,5 m ou dans les coins

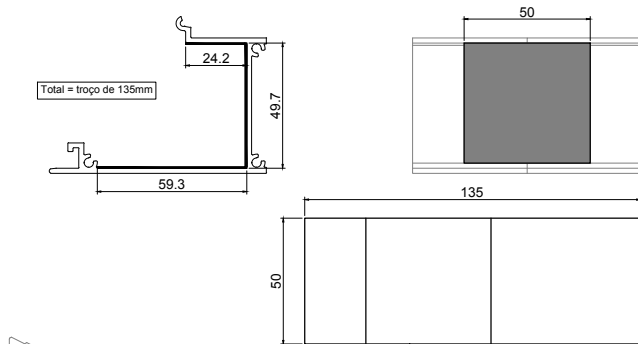

Aplicar nas emendas da caleira: vãos com largura superior a 6,5m e vãos de canto

Apply to the gutter seams: frames with width greater than 6.5m or in corners

Appliquer sur les joints de gouttière: cadres avec largeur supérieure à 6,5 m ou dans les coins

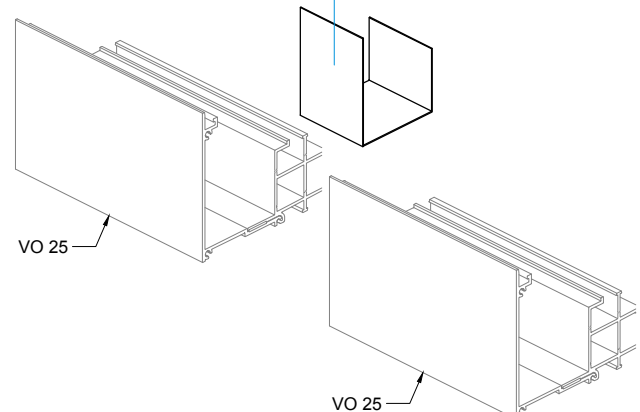
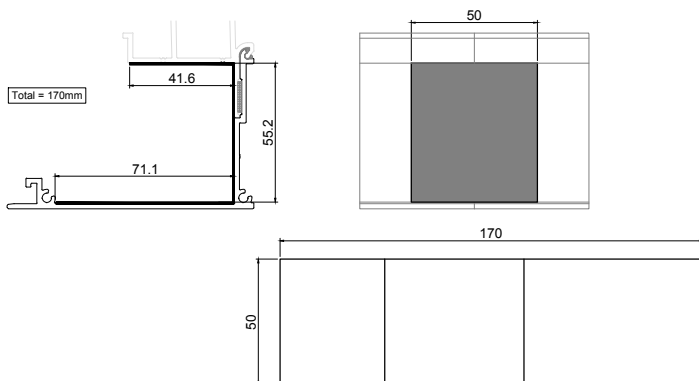
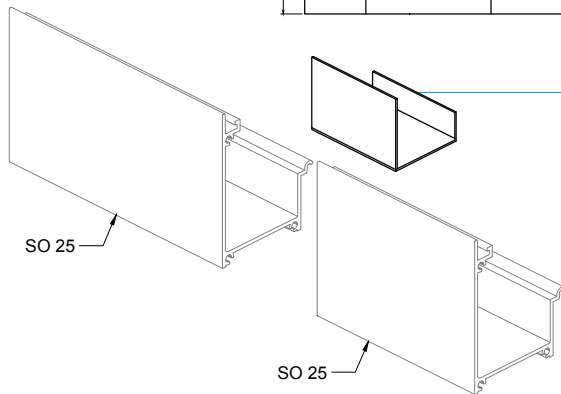

X

ANOTAÇÕES
ANNOTATIONS | REMARQUES

ATUALIZAÇÕES REALIZADAS NESTA VERSÃO CATALOGO TECNICO OS-D+ V04JUL2022 UPDATES DONE IN THIS VERSION LES MISES À JOUR EFFECTUÉES DANS CETTE VERSION	
1	Inseridos os perfis SO 20, SO 30, SO 43, SO 64, SO 65 e SO 66 Insert of SO 20, SO 30, SO 43, SO 64, SO 65 e SO 66 profiles Insertion des profilés SO 20, SO 30, SO 43, SO 64, SO 65 e SO 66
2	Inseridos os perfis reforçados SO 53, SO 57, SO 67 e SO 72 e respetivos acessórios SO 53, SO 57, SO 67 and SO 72 reinforced profiles and their accessories inserted Profilés renforcés SO 53, SO 57, SO 67 et SO 72 et leurs accessoires insérés
3	Removidas as linhas de tratamento do perfil SO 25 (caleira) Treatment lines removed from profile SO 25 (gutter) Lignes de traitement supprimées du profilé SO 25 (gouttière)
4	Inserido o Copo para fecho central OS Inserted the Recessed lock end-cap Inséré l'Embut à encastrer pour serrure
5	Inseridos os perfis de soleira e caleira alta, respetivos acessórios e pormenores de aplicação Sill and high gutter profiles, their accessories and application details inserted Profilés de seuil et de gouttière haute, leurs accessoires et les détails d'application insérés
6	Solução de Fechadura OS - Inseridos os perfis SO 03 e SO 40 e respetivos acessórios. Acrescentadas as respetivas tipologias nos capitulos IV e V. Substituídos os topos laterais pelos novos. OS Lock Solution - SO 03 and SO 40 profiles and accessories inserted. Added the respective typologies in chapters IV and V. Replaced the lateral end-caps with new ones. Solution de serrure OS - Profilés SO 03 et SO 40 et accessoires insérés. Ajouté les typologies respectives dans les chapitres IV et V. Remplacement d'embouts latéraux par des capots neufs.
7	Inseridos os novos aros móveis laterais SO 64, SO 65 e SO 66 nos pormenores e os respetivos acessórios. Substituídos os topos laterais pelos novos Inserted the new SO 64, SO 65 and SO 66 mobile side rims in the details and their accessories. Replaced the end caps with the new ones Insertion des nouveaux ouvrants latéraux SO 64, SO 65 et SO 66 dans les détails et leurs accessoires. Remplacement des embouts latéraux par les nouveaux.
8	Corrigidas as folgas dos vidros nos cortes verticais (estavam erradamente sem qualquer folga) The gaps in the vertical sections of the glass have been corrected (they were incorrectly without any gaps) Les espaces dans le verre des coupes verticales ont été corrigés (ils étaient incorrectement sans espace).
9	Correção da folha da Tabela de enchimentos para vão fixo simples: inserido o perfil KP 35 e substituído o calço de 5mm pelo calço de 3mm Correction to the table sheet for single fixed spans: KP 35 profile inserted and 5mm shim replaced with 3mm shim Correction de la feuille du tableau de remplissage pour les portées fixes simples : insertion du profilé KP 35 et remplacement de la cale de 5 mm par une cale de 3 mm.
10	Corrigidas as quantidades e medidas de corte do OS 95 nas tipologias de soleira oculta Corrected the quantities and cutting measures of OS 95 in the concealed sill typologies Correction des quantités et des mesures de coupe de l'OS 95 dans les typologies de seuils cachés
11	Acrescentada a tipologia 4 folhas com OS 27 - Soleira Oculta Added the 4 sashes typology with OS 27 - Concealed Sill Ajouter le type à 4 feuilles avec OS 27 - Seuil caché
12	Substituído o parafuso ref 290051 pelo parafuso ref 290061 e substituído o parafuso ref 290004 pelo parafuso ref 290099 (as referências anteriores estavam descontinuadas) Replaced screw ref 290051 with screw ref 290061 and replaced screw ref 290004 with screw ref 290099 (previous references were discontinued) Remplacement de la vis réf 290051 par la vis réf 290061 et remplacement de la vis réf 290004 par la vis réf 290099 (les références précédentes ont été supprimées).

13	<p>Aplicação dos Topos OS 63 e SO 43 OS 63 and SO 43 tend-caps application Application des embouts OS 63 et SO 43</p>
14	<p>Atualizados os acessórios e respetivos pormenores da solução de fecho com SO 38 + SO 39 (retirados os art. Fecho embutir 180°, cx transmissão 180° CE esq e dir. Inserido o Fecho embutir OS mono e bidirecionais). Atualizadas as tabelas de medidas de corte e quantidades. Alteração da designação do pormenor, das medidas de corte horizontais e das medidas de corte verticais dos perfis SO 38 e SO 39, nas tipologias JANELA DE CORRER DE EMBUTIR COM 2 FOLHAS 1-RAIL - COM PERFIS SO 38 + SO 39, JANELA DE CORRER 4 FOLHAS - COM PERFIS SO 38 + SO 39 Updated the accessories and related details for the locking solution with SO 38 + SO 39 (removed the 180° recessed lock, 180° CE transmission box left and right. Inserted the OS mono and bidirectional recessed lock). Tables of cutting measures and quantities updated. Change of designation of detail, horizontal cutting measures and vertical cutting measures of profiles SO 38 and SO 39, in the typologies 2 SASHES 1-RAIL POCKET SLIDING WINDOW - WITH SO 38 + SO 39 PROFILES, 4 SASHES SLIDING WINDOW - WITH SO 38 + SO 39 PROFILES. Mise à jour des accessoires et des détails respectifs pour la solution de fermeture avec SO 38 + SO 39 (suppression de la serrure à encastrer à 180°, de la boîte de transmission CE à 180° à gauche et à droite, insertion de la fermeture à encastrer OS mono et bidirectionnelle). Mise à jour des tableaux de tailles et de quantités. Modification de la désignation du détail, des mesures de coupe horizontale et des mesures de coupe verticale des profilés SO 38 et SO 39, dans les typologies FENÊTRE COULISSANT À GALANDAGE 2 VANTAUX 1-RAIL - AVEC PROFILÉS SO 38 + SO 39, FENÊTRE COULISSANT 4 VANTAUX - AVEC PROFILÉS SO 38 + SO 39.</p>
15	<p>Inserida a informação sobre Solução de canto: aplicação dos topos Inserted information about Corner solution: end-caps application Insertion d'informations sur la solution de l'angle : application des embouts</p>
17	<p>Atualizada a informação sobre os Kits Fecho Magnético Updated information on the Magnetic Lock Kits Mise à jour des informations sur les kits de fermetures magnétiques</p>
18	<p>Substituído o Gabarito para contra-fechos OS N°2 OS No. 2 counter-lock gauge replaced Remplacement du gabarit de contre-fermeture OS No. 2</p>
19	<p>Retirado o perfil OS 33 e o Topo para OS 33 OS 33 profile and End-cap for OS 33 removed Profilé OS 33 et Embout pour OS 33 supprimé</p>
20	<p>Substituídos os parafusos PF DIN7981 3.5x32 pelos PF DIN7981 3.5x38, no capítulo VIII - pré-aros Replaced PF DIN7981 3.5x32 screws with PF DIN7981 3.5x38 screws, in chapter VIII - pre-frames Remplacement des vis PF DIN7981 3,5x32 par des vis PF DIN7981 3,5x38, au chapitre VIII - pré-cadres</p>
21	<p>Corrigidas as medidas de corte OS 95 (JANELA DE CORRER 4 FOLHAS - COM PERFIL OS 27 - Sol. Tradicional) Corrigida medida de corte do perfil OS 41 pequeno na tipologia Janela de correr 3 folhas (3-Rail soleira oculta) e na respetiva página do capítulo das Maquinações e ainda dos perfis SO 14, OS 801 e OS 35 na tipologia "Janela de correr de embutir com 2 folhas 1-rail - COM PERFIS SO 38 + SO 39" (soleira tradicional). OS 95 cutting measures corrected (4-LEAF SLIDING WINDOW - WITH OS 27 PROFILE - Classic Sill) Corrected the cutting measure of the short OS 41 profile in the 3-leaf sliding window typology (3-Rail concealed sill) and on the corresponding page of the Machining chapter, as well as the SO 14, OS 801 and OS 35 profiles in the "2-leaf 1-rail pocket sliding window - WITH SO 38 + SO 39 PROFILES" typology (traditional sill). Correction des dimensions de coupe de l'OS 95 (FENÊTRE COULISSANTE À 4 VANTAUX - AVEC PROFIL OS 27 - Seuil Classique) Correction de la dimension de coupe du profilé OS 41 de petite taille dans le type de fenêtre coulissante à 3 vantaux (seuil caché à 3 rails) et sur la page correspondante du chapitre Usinage, ainsi que des profilés SO 14, OS 801 et OS 35 dans le type "Fenêtre coulissante à 1 rail à 2 vantaux - AVEC PROFILS SO 38 + SO 39" (seuil classique).</p>

22	<p>Nas tipologias para vãos fixos - soleira tradicional, foram substituídos os perfis SO 15 + SO 16 da padieira pelo perfil SO 14</p> <p>In the typologies for fixed spans - classic sill, the SO 15 + SO 16 profiles of the lintel were replaced by the SO 14 profile</p> <p>Dans les typologies pour travées fixes - seuil classique, les profilés SO 15 + SO 16 du linteau ont été remplacé par le profilé SO 14.</p>
23	<p>Substituídas as pelúcias 7x7 pelas 7x7 S-Fin em todas as alturas dos pormenores, exceto nos perfis SO 38 e 39 que se mantém a 7x5.5</p> <p>7x7 pile seal by 7x7 S-Fin in all the heights of the details, except for the SO 38 and 39 profiles which remain 7x5.5</p> <p>Remplacement de la joint brosse 7x7 par le S-Fin 7x7 dans toutes les hauteurs des détails, à l'exception des profilés SO 38 et 39 qui restent 7x5.5</p>
24	<p>Substituídos os perfis SO 15 e SO 16 pelo SO 14 nas padieiras das tipologias vãos fixos (soleira tradicional e soleira oculta).</p> <p>SO 15 and SO 16 profiles replaced by SO 14 in the fixed door lintel (classic sill and concealed sill).</p> <p>Remplacement des profilés SO 15 et SO 16 par le SO 14 dans les linteaux de porte fixes (seuil classique et seuil caché).</p>
25	<p>Retirado o Fecho Central OS N.3 (Refª 201066) e substituído o fecho lateral OS N.3 (Ref 201065) pelo Fecho lateral OS N.4 (Ref. 201089)</p> <p>OS N.3 Central Lock (Ref. 201066) removed and OS N.3 Side Lock (Ref. 201065) replaced by OS N.4 Side Lock (Ref. 201089)</p> <p>Suppression de la fermeture centrale OS N.3 (Réf. 201066) et remplacement de la fermeture latérale OS N.3 (Réf. 201065) par la fermeture latérale OS N.4 (Réf. 201089)</p>
26	<p>Alteração dos perfis OZ 05, OZ 11 e OZ 14 que alteram os perfis SO11, SO 12, SO 13, SO05, SO06, SO 07, SO 14 e SO15</p> <p>Modification of profiles OZ 05, OZ 11 and OZ 14 which modify profiles SO11, SO 12, SO 13, SO05, SO06, SO07, SO 14 and SO15</p> <p>Modification des profilés OZ 05, OZ 11 et OZ 14 qui modifient les profilés SO11, SO 12, SO 13, SO05, SO06, SO07, SO 14 et SO15.</p>
27	<p>Inseridos os Cilindros 35-35 e 35B-35</p> <p>Cylinders 35-35 and 35B-35 inserted</p> <p>Insertion des cylindres 35-35 et 35B-35</p>
28	<p>Substituição do Canto de alinhamento OS (Ref 213017) pelo Canto de alinhamento OS nº2 (ref 213018). Atualização na lista de acessórios e nas tabelas de quantidades</p> <p>Replacement of the OS alignment corner (ref 213017) by the OS alignment corner no. 2 (ref 213018). Update to the list of accessories and tables of quantities</p> <p>Remplacement des angles d'alignement OS (réf. 213017) par les angles d'alignement OS nº2 (réf. 213018). Mise à jour de la liste des accessoires et des tableaux de quantités</p>
29	<p>Introdução do perfil SO 10 canto reduzido 90°</p> <p>Insertion of the SO 10 reduced corner profile 90°</p> <p>Introduction de profilé SO 10 à angle réduit de 90°</p>
30	<p>Removido o perfil OS 55 e todos os acessórios, maquinações e montagens</p> <p>Removed OS 55 profile and all accessories, machining and assemblies</p> <p>Suppression du profil OS 55 et de tous les accessoires, de l'usinage et de l'assemblage</p>
31	<p>Introdução do Tapa furos isolado Ref 210604 (já existia mas era fornecido em conjunto com o Amortecedor OS N3 ref 213220)</p> <p>Insertion of the Hole cover Ref 210604 (already existed but supplied together with OS N3 shock absorber ref 213220)</p> <p>Introduction du Capot de trou isolé Réf 210604 (existait déjà mais fourni avec l'amortisseur OS N3 réf 213220)</p>

32	<p>Substituição do parafuso por outro comprido nos topos inferiores laterais de folha soleira oculta + tapa furos</p> <p>Replacement of the screw by a longer one in the lateral lower end-caps of the concealed sill sash + Hole cover.</p> <p>Remplacement de la vis par une vis plus longue dans l'embouts supérieures latérales inférieures du seuil caché + Capot de trou.</p>
33	<p>Inseridos os novos perfis KE 96 e KE 97 e os suportes e angulos de fixação de 160mm e 180mm</p> <p>Inserted the new KE 96 and KE 97 profiles and the 160mm and 180mm brackets and fixing angles</p> <p>Insertion de nouveaux profilés KE 96 et KE 97 et de supports et équerres de fixation de 160 mm et 180 mm</p>

Este Catálogo Técnico poderá sofrer alterações por motivos técnicos, sem aviso prévio.

Qualquer encomenda deverá ser sujeita a confirmação dos nossos serviços.

A publicação do presente catálogo técnico anula qualquer versão prévia em vigor, sendo válida até nova atualização.

This Technical Catalogue might be subjected to changes due to technical reasons, without previous warning.

All orders must pass through the confirmation of our technical services.

The publication of this technical catalogue cancels any previous version in use, and is valid until a new update.

Ce Catalogue Technique pourra être modifié sans pré avis de notre part, due à des raisons techniques.

Toute commande devra être confirmée par nos services.

La publication de ce catalogue technique annule toute version antérieure en vigueur, et est valable jusqu'à une nouvelle mise à jour.



Licença nº 1406 - SOSOARES
Licença nº 1411 - ALFA SUL



Licença nº 809 - SOSOARES
Licença nº 817 - PORTALEX

ALFA SUL

EN Lisboa-Sintra Km 14
2725-397 Mem Martins

T +351 219 265 090* | F +351 219 265 098*
E alfa.sul@sosoares.pt

ALULIDER

Pavilhão Industrial H - Plataforma 13D
Zona Franca Industrial
9200-047 Caniçal - Madeira

T +351 291 960 494* | F +351 291 960 497*
E alulider@sosoares.pt

PORTALEX

Estrada de S. Marcos, 23
2735-521 Cacém

T +351 210 412* | F +351 210 412 507*
E comercial@portalex.eu

SOSOARES

Rua do Campo Alegre, 474
4150-170 Porto

T +351 226 096 709* | F +351 226 005 642*
E comercial@sosoares.pt

*Chamada para rede fixa nacional Portuguesa
Portuguese fixed network call
Appels vers le réseau fixe Portugais

www.sosoares.pt
www.portalex.eu